

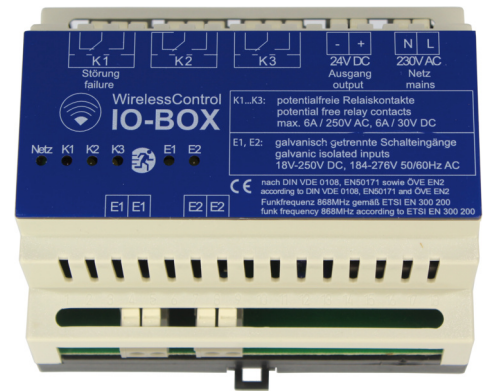

Art.-Nr: WLI032

The IO-box is an interface module of the automatic test and control system for emergency lighting Wireless Professional, whose inputs and outputs signalise states and conditions of and to the test and control system. The IO-box has 3 outputs in form of potential-free changeover contacts, of which contact 1 is used for a system disturbance combined fault indication. The other two contacts can be programmed by means of the Wireless Professional software, in order to signalise various system states.

Furthermore, there are 2 galvanically isolated switch inputs to integrate control and/or sensor signals of e.g. an external test pushbutton or a key switch.



More information

www.rp-group.com/en/item/WLI032

TECHNICAL DATA

Input voltageAC	230 V V
Input frequency	50 / 60 Hz
Depth	60 mm
Width	105 mm
Height	85 mm
Weight	0.36 kg
Customs tariff number	85176200
EAN	4260123690045

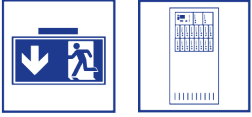

TECHNICAL DRAWING

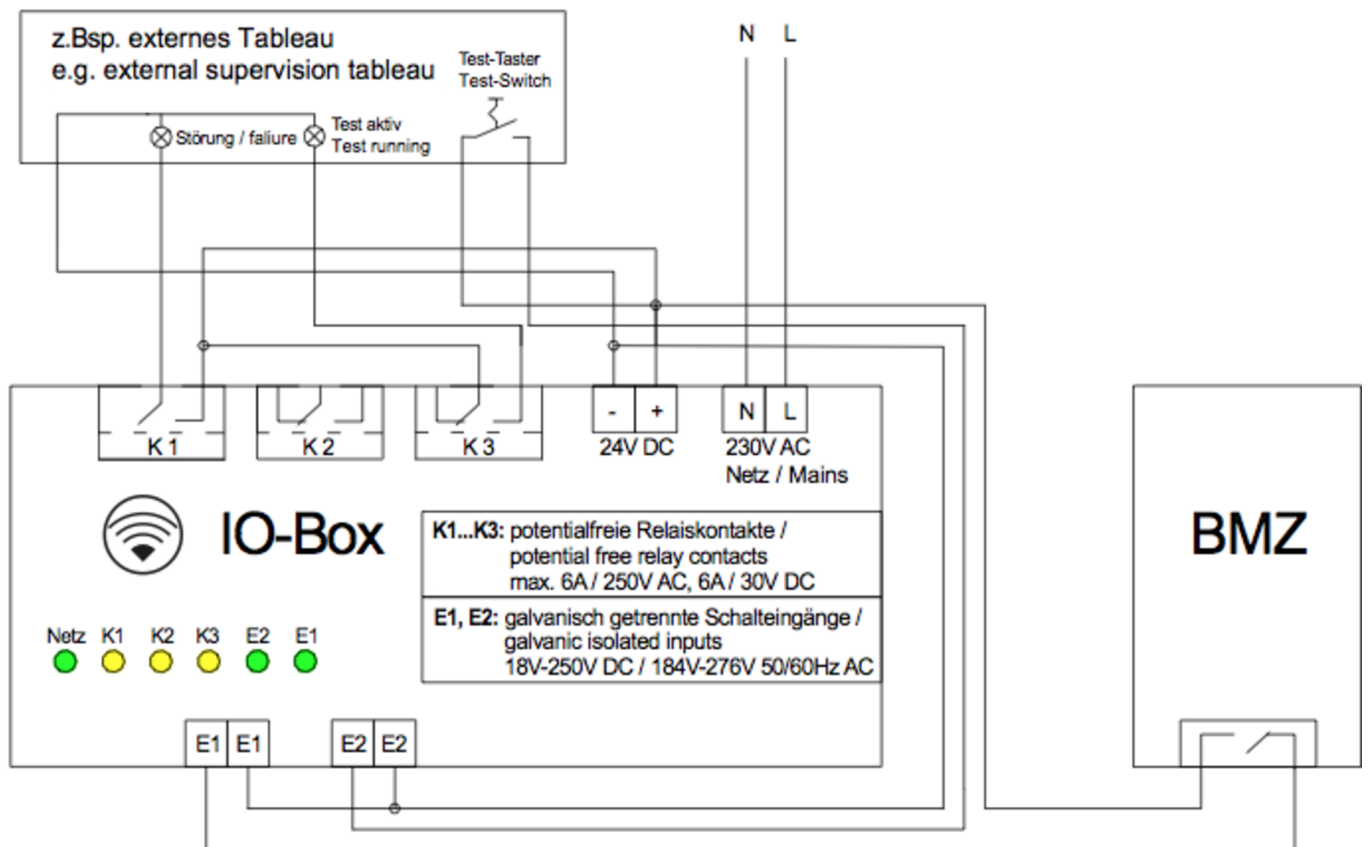
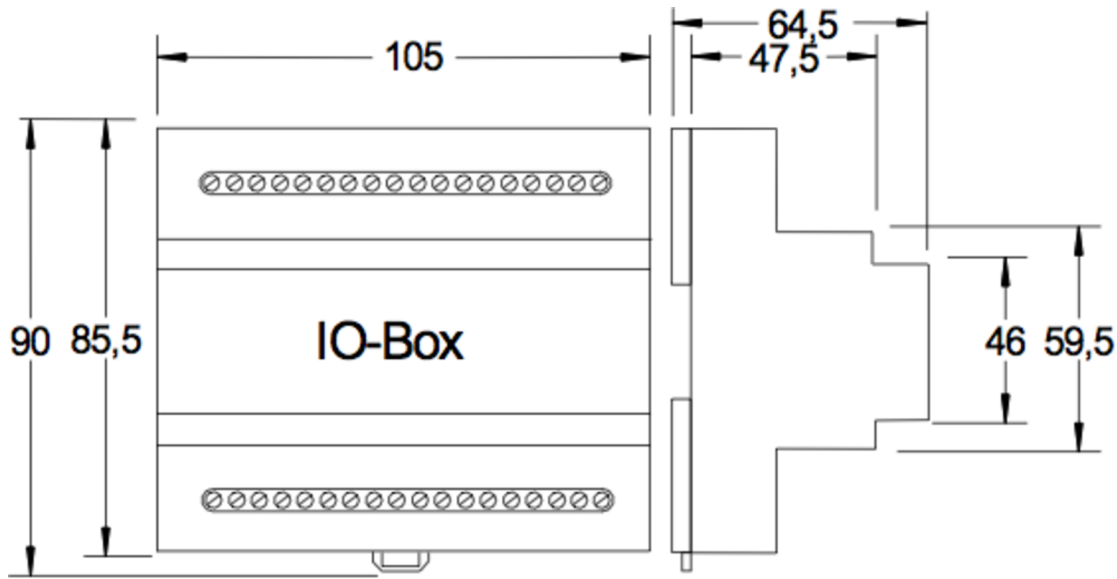
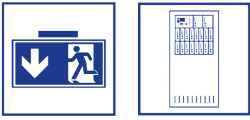

As of: 23.08.2024 - Subject to technical changes and errors.