



Art.-Nr: MI106
microControl plus (MI) Central battery system Combined housing
Central battery system, Combined housing, 3 pcs. DCM, 1 pcs. LDM,
Leuchten

MAX. 6 MAINS CIRCUITS / 500 W, 1H / 120 LUMINAIRES

The microControl plus is a decentralized power supply system with limited power (Low Power system) up to 500 W.

By decentralising the systems, similar to a self-contained system, per fire compartment reduces costs because no expensive E30-powerlines acc. to MLAR 2005 and their installation are needed.

Batteries are not included and have to be ordered separately.



More information



TECHNICAL DATA

Inserts	4 pcs.
Number of DCM modules	3 pcs.
Number of circuits	6+1(Hilfsstromkreis)
Loader	Yes
Number of charging modules	1 pcs.
Modules SAM	Yes
IO modules	Yes
CCIF	Yes
Connectable	Yes
Outgoing UPS	No
Battery compartment	Yes
Supply power 1 h	500 W
Supply power 3 h	200 W
Supply power 8 h	80 W
Input voltage AC	230 V V
Input frequency	50 / 60 Hz
Output voltage AC	230 V



Material	Steel sheet
Housing color	Light grey
Insulation class	IP20
Insulation class	IP20
Depth	230 mm
Width	350 mm
Height	660 mm
Weight	22.4 kg
Weight	22.4
Customs tariff number	85371098

TRANS.MASSZEICHNUNG

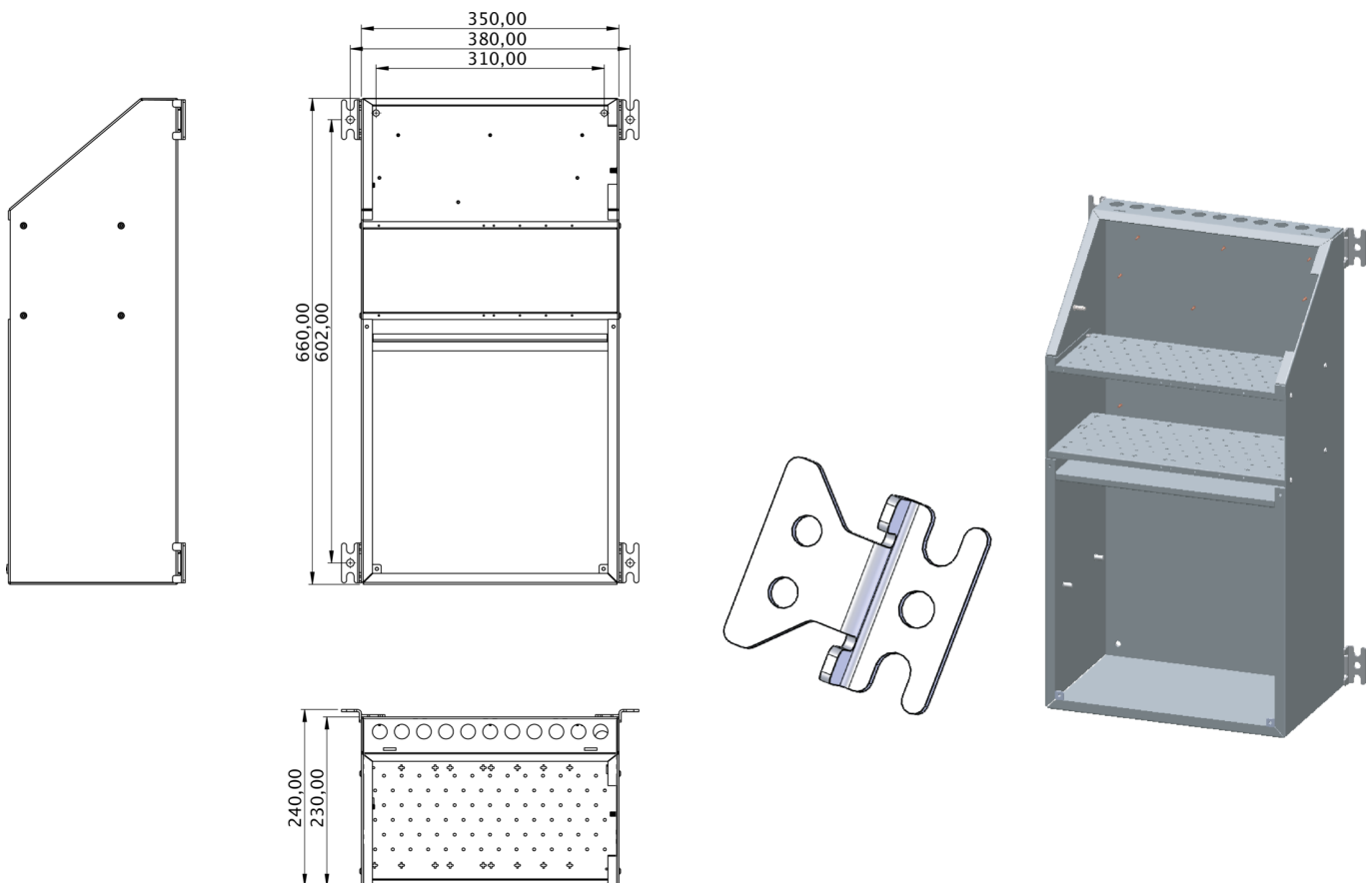

As of: 24.07.2024 - Subject to technical changes and errors.