



**PIONEERING
IN EVERY
RESPECT**



EMERGENCY LIGHTING AND CENTRAL POWER SUPPLY SYSTEMS 2024/25

MADE IN GERMANY

RF GROUP
SOLUTIONS IN SAFETY + LIGHTING

RP-GROUP CREATES SAFETY. THROUGH INVENTIVENESS, QUALITY AND SERVICE.

Today, RP Group products are an integral part of public, commercial and industrial buildings. For more than 40 years, we have been ensuring a high level of safety in buildings with innovative and design-oriented emergency lighting.

As the inventor of the tapered escape sign luminaire series (KMU), we were one of the leading manufacturers and one of the first to use energy-saving LED technology. But sustainability also

plays a decisive role in our own buildings. For example, we have invested in around 800 solar panels that are used entirely for our own purposes. Around 20 charging stations now power our electric vehicles.



Today, the RP Group employs around 300 highly qualified and committed employees in Germany and abroad and has expanded its product portfolio to include smart lighting control components, batteries in lithium and pure lead technology and photovoltaic systems.

The performance and quality of our products are our top priority. That is why we develop and manufacture our emergency and safety luminaires as well as our central power supply systems in Germany and are proud of Made in Germany.





5

TIME CERTIFIED QUALITY

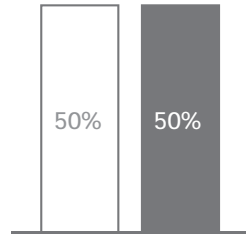

50 %

EXPORT RATE



53

OWN PATENTS

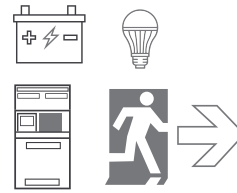

3.000

PRODUCTS

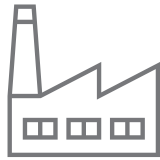

15.000

m² PRODUCTION SPACE



3

DESIGN AWARDS



5.000

m² STORAGE SPACE



5

YEARS WARRANTY ON MANY PRODUCTS



CONTENT – EXIT- AND EMERGENCY LUMINAIRES

GENERAL INFORMATIONS

DIALUX Partnership	8
Novelties - Available soon	9
Order key	10
Legend	11
Protection categories	12
Piktographs.....	14
The innovative lens system FlexiClick.....	16

DESIGN LUMINAIRES

ASMU	20
A-Series	24
GA-Series.....	70
EE-Series.....	80
EA-Series	86
DDE	88
FMW.....	90
FMDS	92
WEF	94
WER.....	96
WAF.....	98
ZAW.....	100
UEMR	104

DYNAMIC LUMINAIRES

FLEXWAY	108
---------------	-----

UNIVERSAL-LUMINAIRES

KFMU	114
KM-Serie (KMMU / KFMU / KMUK)	116
KSU	122
KSC.....	124
KA-Serie.....	130
KBU	134
IL.....	138
IADL	146
KMB	148
DO	152

INDUSTRIAL-LUMINAIRES

PM	158
KC	160
KD / KL.....	166
LM / LX / LS	172
KWI.....	178
LBLT	182
Cube luminaires WH.....	184
Cube luminaires WK / WG / WX.....	188
Square luminaires WFXW.....	192
Explosion proof luminaires XI / XM / XX.....	194
SKS / SGS	200
HX.....	204

GENERAL-PURPOSE LIGHTING FOR SAFETY USE

QAW	208
QBW.....	210
QCW.....	212
LFD.....	214
FLU.....	216

WIRELESS LUMINAIRE MONITORING

Wireless Basic and Lightlinx®.....	218
Wireless Professional	220
Wireless IO-Box	223

ACCESSORIES

Wall brackets and Pendant fittings.....	224
Ball protection	225

MODULES

MLED500, NT24.....	230
LPK, LEM, LEX, WRLED413, LEO.....	231
Self-contained power supply NVG	232

CONTENT – SAFETY POWER SUPPLY SYSTEMS

GENERAL INFORMATIONEN	
Applicable Standards.....	236
The Systems family	238
Low Power Systems.....	240
Central Battery Systems.....	242
The CPU.....	248
The Web-Interface	250
LOW POWER SYSTEMS	
CoreCompact 24	252
microControl <i>plus</i>	254
miniControl <i>plus</i>	256
miniContro XLI <i>plus</i>	258
CENTRAL BATTERY SYSTEMS	
midiControl <i>plus</i>	260
multiControl <i>plus</i>	262
MDC	268
SUBSTATIONS AND SUBDISTRIBUTIONS	
multiControl <i>plus</i> US / microControl <i>plus</i> US.....	270
MDEV	272
MDEV-E.....	274
Related accessories per system type	276
System dimensioning	278
ACCESSORIES AND MODULES	
Mains circuit modules	280
Relay circuit module, Charger module.....	281
IO-Module, Switch query module	282
Closed current loop, Line monitor	283
Remote panel	284
Connection to building management systems	285
Power down switch	286
MU06, UH-1, MU-BOX.....	287
MLED500	288
Battery cabinets	289
BATTERIES AND BATTERY MONITORING	
OGiV LP.....	290
OGiV FT.....	294
OGiV HP.....	296
BAT-LOGG® Battery monitoring.....	298



PATENTS AND CERTIFICATES – DOCUMENTED INNOVATIVE STRENGTH

We are owners of 53 patents in the field of emergency lighting. Our internal quality assurance system and various certifications ensure that our products meet the highest standards of reliability and safety.

RP-Technik GmbH is successfully certified or recertified according to the following standards: zertifiziert:

- Recertification ISO 9001 for company processes
- ISO 45001 for occupational health and safety
- ISO 14001 for environmental management system
- ISO 50001 for energy management

In addition, a large number of our products are type approved by TÜV Rheinland.

Our systems production in Saalfeld is also subject to strict quality controls and has been certified by TÜV SÜD. Already during production, we test the individual components of the power supply systems. As well, each system is subjected to a 24-hour endurance test before delivery.

Furthermore, we consistently use energy-saving technologies in the development of our products and environmentally friendly, recyclable materials in production.

DESIGN AND FUNCTIONALITY – AN EXCELLENT COMBINATION

Our internal product design ensures functional aesthetics, for which RP-Technik has already received several awards. The A series was awarded the German Design Award in the “Excellent Product Design, Lighting” category in 2018. The lights in the KFMU and PM series were nominated for the German Design Award.



A-series



KFMU-Serie



PM-Serie



OUR PRODUCT TRAINING COURSES – COMPACT, CONSTRUCTIVE, CUSTOMIZED

Future-oriented emergency lighting requires competent further training: Our training courses are tailored to the needs of our customers and a clear recommendation for every professional. They consist of teaching important theoretical knowledge combined with a high percentage of hands-on training. We offer the following topics:

- General questions on the installation and set-up of emergency lighting systems in accordance with applicable national and European standards and regulations
- Operation and function of our portfolio of emergency lighting products
- Operation, function and programming of our power supply systems and modules
- Maintenance and service according to applicable regulations
- Troubleshooting



PLANNING-TOOL

The participants of the planner events carried out together with our premium partners will receive our exclusive and comprehensive guide to the planning of emergency and safety lighting: The Planning Tool.

QUICK ACCESS – FOR FURTHER PRODUCT INFORMATION

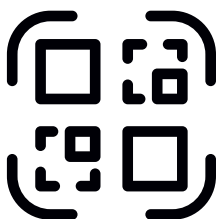

On each page of a product group there is a QR code that takes you to our website with further information, data sheets, operating instructions and installation videos.

DIALUX PARTNERSHIP



Since 2022, the RP Group has entered into a partnership with DIAL. All products are now available directly in the successful and well-known planning software DIALux and can be used directly for planning emergency and safety lighting.

In addition to the wide range of products, the RP Group's products are also available in DIALux as a 3D object.

About DIALux:

DIAL develops software tools and planning strategies, plans lighting and building automation systems and conveys the knowledge acquired in planning, research and testing and the practical experience in seminars.

With DIALux, DIAL is developing the internationally leading planning tool for lighting planning of indoor and outdoor spaces. DIALux not only makes professional lighting planning easier and accessible to everyone. As a platform and tool, it connects planners and manufacturers all over the world.

What are the advantages of DIALux?

- Simple, effective and professional lighting planning.
- Always up-to-date and technically state-of-the-art software available to the user free of charge.
- Optimal coordination with the existing planning workflow.
- Planning of entire buildings including the outdoor space.
- Calculation of street scenes according to EN-13201.
- Planning with color filters, colored light sources and colored materials.
- Integrated ray tracing module creates a photorealistic appearance.
- Energy assessment in the shortest possible time.
- Visualization of transparent materials in the CAD.
- Dimensioning and labeling directly in the CAD.

NEW PRODUCTS IN DEVELOPMENT

> QD



- General- and Emergency lighting
- IP65



> PX



- Polycarbonate housing
- 30m Recognition distance
- IP65
- Wall mounting



> KQ



- Polycarbonate housing
- 30m Recognition distance
- IP65
- Ceiling mounting



KQ Exit sign



KQ safety luminaire

ORDER KEY

The cases shown on the following pages are empty casings, the order numbers which are composed of the casing description and the method of mounting. Colour options for the casings are available at additional cost.

Order key according to mounting technique

- W = Wall mounting
- D = Ceiling/Outrigger mounting
(wall bracket must be ordered separately)
- U = Universal mounting wall / ceiling
- E = Recessed mounting
- C = recessed ceiling mounting
- R = recessed wall mounting

Lenses

- F = focused lens for corridors
- R = radiate lens
- H = high bay lens
- S = spot lens
- L = system lens (corridor / radial)

Monitoring options

- ML = monitoring / luminaire monitoring
- SC = Self-Control monitoring
- WL = Wireless Professional monitoring
- WB = Wireless Basic® monitoring
- CC = Core Compact 24V-system

The order numbers of casings with light fittings are composed of the order number of the case type, the order number of the chosen fitting and if necessary the number of the monitoring module. The order numbers for the fittings can be found in the respective type table

Light-fittings order key

001	EB *	LED LowPower, 1h
003	EB *	LED LowPower 3h
011	EB *	LED HighPower 1h
013	EB *	LED HighPower 3h
018	EB *	LED HighPower 8h
021	EB *	ERT (Escape Route Type) LED / 1h
023	EB *	ERT (Escape Route Type) LED / 3h
028	EB *	ERT (Escape Route Type) LED / 8h
031	EB *	ERT (Escape Route Type) LED / 1h
033	EB *	ERT (Escape Route Type) LED / 3h
038	EB *	ERT (Escape Route Type) LED / 8h
401	EB * - LiFePo4	LED LowPower, 1h
403	EB * - LiFePo4	LED LowPower 3h
408	EB * - LiFePo4	LED LowPower 8h
411	EB * - LiFePo4	LED HighPower 1h
413	EB * - LiFePo4	LED HighPower 3h
418	EB * - LiFePo4	LED HighPower 8h
421	EB * - LiFePo4	ERT (Escape Route Type) LED / 1h
423	EB * - LiFePo4	ERT (Escape Route Type) LED / 3h
428	EB * - LiFePo4	ERT (Escape Route Type) LED / 8h
433	EB * - LiFePo4	ERT (Escape Route Type) LED / 3h
009	CPS * 230V	LED LowPower
019	CPS * 230V	LED HighPower
029	CPS * 230V	ERT (Escape Route Type) LED
039	CPS * 230V	ERT (Escape Route Type) LED
509	CPS * 24V	LED LowPower
519	CPS * 24V	LED HighPower
529	CPS * 24V	ERT (Escape Route Type) LED

*EB = Self-Contained | * CPS = Central powered system









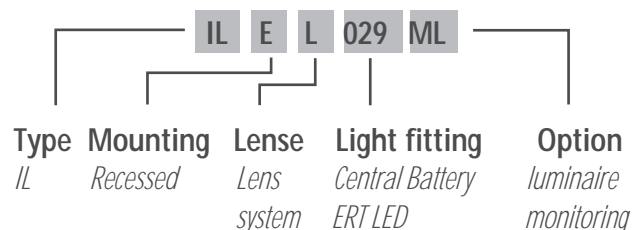

























Order number



Order number



















LEGEND

	Insulation class I; PE conductor connection required		Ball protection available
	Insulation class II; luminaire is insulated		Recessed mounting frame available
	ENEC certified luminaire		Wall bracket available
	Recognition distance in meters		Ballproof luminaire
	Universal mounting on wall or ceiling possible.		Optional accessory design pendant fitting
	Complete set of pictographs included (left / right/ up / down)		Optional accessory standard double pendant fitting white (2DW) or silver (2PV).
	IK-Shock resistance level		Optional accessory cord suspension (standard length 0.5m).
	Luminaire suitable for use in explosive atmospheres		Luminaire is available with separate housing for battery and/or electronics.
	Light planning data of the luminaire are available.		Optionally available with a pre-assembled 3-phase adapter. This enables tool-free installa- tion in standard 3-phase rails.
	Protection class		Luminaire may be monitored with central battery systems.
	5 years warranty on electronics, LED and battery. Applies to all self-contained luminaires with LiFePO4 battery.		Self-contained luminaire with integrated auto- mated self testing module – Self-Control.
	Type approved product		Luminaire is available with radio module for connection to the Wireless Professional system. Luminaire can be switched via Wireless Professional (unless otherwise stated.)
	Food safe		Luminaire is available with radio module for connection to the Wireless Basic system.
	Version		Luminaire for connection to a 24V Core Compact central battery system.
	Emergency operating time of the luminaire (CBS = Central battery system)		max. power consumption
	Colour options		Luminous flux in emergency mode
			Battery data

Note: „max. consumption“ refers to the maximum power consumption (for example, including battery charge) of the luminaire.

INTERNATIONAL PROTECTION CLASSES

ACCORDING TO DIN EN 60529

Code letters International Protection		First index Contact protection	Second index Protection against water		
Ziffer		Protection	Ziffer	Protection	
IP		6	5		
0		No protection against accidental contact, no protection against solid foreign bodies	0		No protection against water
1		Protection against contact with any large area by hand and against solid foreign bodies with $\varnothing > 50$ mm	1		Protection against vertical water drips
2		Protection against contact with the fingers, protection against solid foreign bodies with $\varnothing > 12$ mm	2		Protection against water drips (up to a 15° angle)
3		Protection against tools, wires or similar objects with $\varnothing > 2,5$ mm, protection against solid foreign bodies with $\varnothing > 2,5$ mm	3		Protection against water drips (up to a 60° angle)
4		As 3, however $\varnothing > 1$ mm	4		Protection against splashed water from all directions
5		Full protection against contact, protection against interior dust deposits	5		Protection against water (out of a nozzle) from all directions
6		Total protection against contact, protection against penetration of dust	6		Protection against powerful water jets
diagram in accordance with DIN EN 60529 (VDE 0470-1):2014-09 EN 60529:1991 + A1:2000 + A2:2013			7		Protection against temporary immersion
			8		Protection against water pressure

IK - IMPACT RESISTANCE GRADE



The IK impact resistance rating is a measure of the resistance of components to impact and shock loads. According to the international standard IEC 62262 or EN 62262, it describes degrees of protection provided by housings for electrical equipment (equipment) against external mechanical stress.

Code	Impact energy in joules	Corresponds to the fall height of the mass
IK00	no protection	
IK01	0,14	7 cm – 200 g
IK02	0,20	8 cm – 250 g
IK03	0,35	14 cm – 250 g
IK04	0,50	20 cm – 250 g
IK05	0,70	28 cm – 250 g
IK06	1,0	40 cm – 250 g
IK07	2,0	40 cm – 500 g
IK08	5,0	25 cm – 2 kg
IK09	10,0	20 cm – 5 kg
IK10	20,0	40 cm – 5 kg
IK10+	50,0	50 cm – 10 kg

ONE LUMINAIRE THAT FITS ALL NEEDS

Former order method

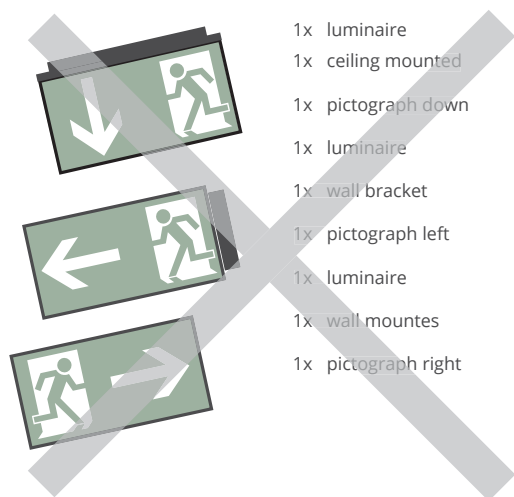

Our products feature the latest technology. Many of our luminaires can be mounted universally and are delivered with a complete set of pictographs. This saves you time and prevents inconvenient planning. You just have to order the needed number of luminaires - no extra orders for pictographs or mounting equipment.



Pay attention to these symbols for luminaires which feature universal mounting and / or are delivered with a complete set of pictographs.



Split pictograms

The luminaires of the PM and KFMU series are equipped with the new split pictograms, which protect the environment by using less material, but still offer maximum flexibility at the installation site thanks to all the arrow directions included

Our order method

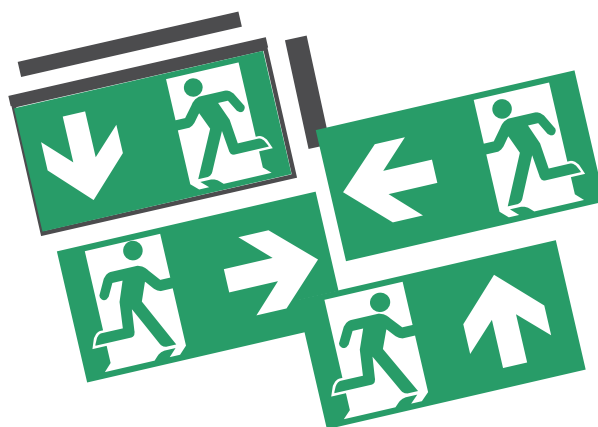

3x luminaire, universal mounting incl. complete set of pictographs

Benefits for planners

- Only one order needed for all mounting types and pictographs

Benefits for distributors

- Less storage space required
- Only one type in stock
- Less administration costs

Benefits for installers

- Flexible handling - even while mounting the device

➤ PICTOGRAPHS

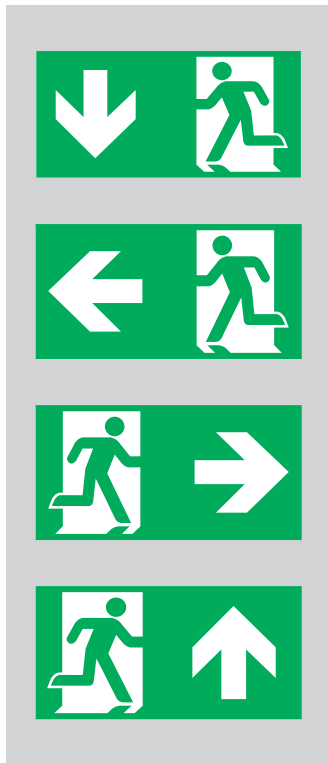

01 MTU
escape route straight

02 MTL
escape route left

03 MTR
escape route right

15 MTO
escape route straight on



05 TLO *
upstairs left

06 TLU *
downstairs left

07 TRO *
upstairs right

08 TRU *
downstairs right

Examples: special labeling based on customer preference *

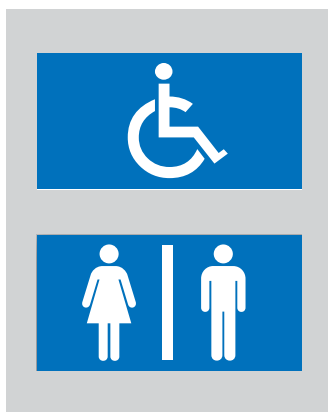

Pictographs according to DIN 4844-2 T1+2 DIN EN 7010, DIN ISO 3864-1 and new BGV A8 as well as NFPA/LifeSafetyCode.

If you would like to order pictographs individually, please indicate the luminaire type.

Non-standard pictographs are available at additional charge, though delivery times might be longer.





Fire extinguisher *
special pictograph, silk-screen print or cutted foil

Fire alarm *
special pictograph, silk-screen print or cutted foil

Fire hose *
special pictograph, silk-screen print or cutted foil

Fire fighting Equipment *
special pictograph, silk-screen print or cutted foil

Also available as a pictograph set for mid-sized edge luminaires



Defibrillator *
special pictograph, silk-screen print or cutted foil

First Aid *
special pictograph, silk-screen print or cutted foil

Collection point *
special pictograph, silk-screen print or cutted foil

Emergency exit with escape ladder *
special pictograph, silk-screen print or cutted foil

Also available as a pictograph set for the KSC luminaire

* = **Special pictographs (additional price)**

Basically all kinds of labeling are possible, also multicolored.

Please send object drawings in vector format, otherwise the post-processing must be cleared by time.

Material for use: acrylic glass (standard), glass and float-glass.



**Flexi
Click**

The perfect emergency luminaire for every installation location, every installation situation and every operating concept.

EXCHANGEABLE LENSES FOR OPTIMUM LIGHT DISTRIBUTION.

Innovative emergency and safety lighting made in Germany has a name: RP-Group. With progressive and well conceived solutions, we have been setting the trends on the market for years. The best examples of this are our emergency luminaires of the E and IL series, which, thanks to their discreet design and a wide range of variants, can be optimally adapted to the architecture and requirements of a wide variety of buildings.

In the comprehensive luminaire system from RP-Group, you will find the ideal emergency luminaire for every installation location, every installation situation and every operating concept. For optimum light distribution, four specific lenses are available per luminaire for a

wide range of applications, which are inserted directly into the respective luminaire at the installation location by means of quick mounting. This facilitates and increases flexibility during installation. In addition to the four lenses for the main areas of application (circular, corridor, spot, beam), two other lens types are available. With its elongated beam angle, the H lens is designed for use in long escape routes with ceiling heights well over 4 meters. The WF lens, on the other hand, is used in wall safety luminaires where an extended beam angle towards the middle of the corridor is required.

CIRCULAR LENS

Circular emitting lens for escape and rescue routes. Ideally suited for large open areas such as restaurants or conference rooms.

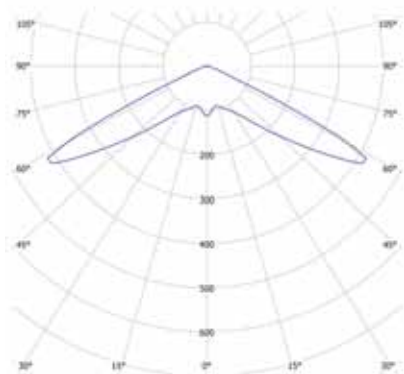

CORRIDOR LENS

Lens focused in two main directions for luminaire Luminaire spacing up to 24 metres. Fully illuminates long escape routes or corridors even with ceiling heights over 4 metres.

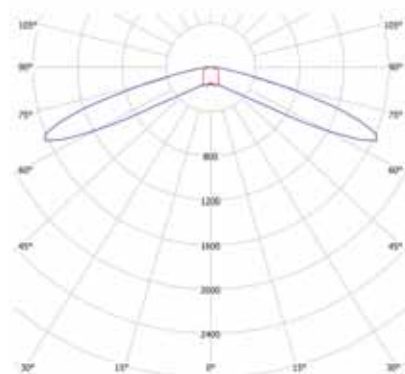
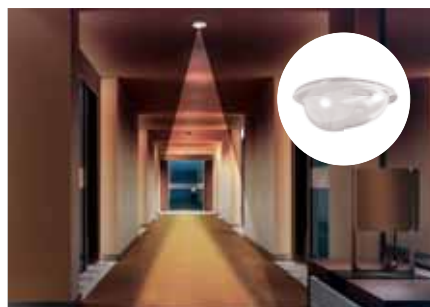

SPOT LENS

The spot lens ensures an even distribution of light in all directions. Suitable for ceiling heights well above 4 metres, such as in a production facility. Can also be used for open areas in hotels (operating time 8 hours).

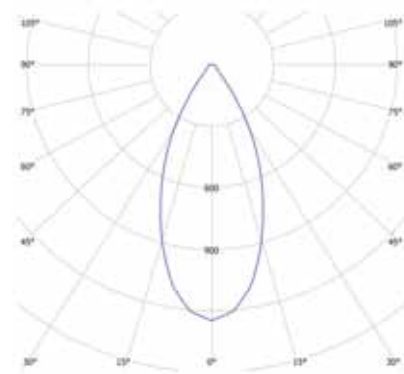

BEAM LENS

The beam lens is used for additional illumination of wall-mounted fire-fighting, reporting and first-aid equipment as well as escape and rescue plans with the normally required luminous intensity of 5lx.

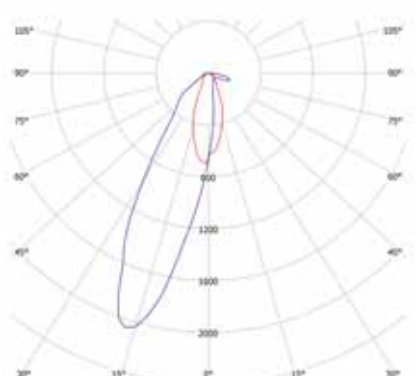

H-LINSE

The H-lens is optimized for mounting height from 4 meters on. It directs the light in two main directions for the illumination of escape routes and corridors.

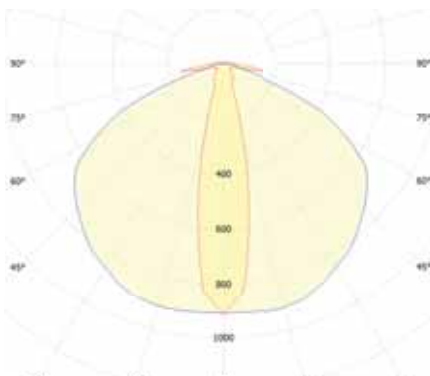

WF-LINSE

The WF lens directs the light laterally towards the middle of the corridor in wall-mounted security luminaires. In low room heights, greater distances can be achieved than with ceiling-mounted lights.

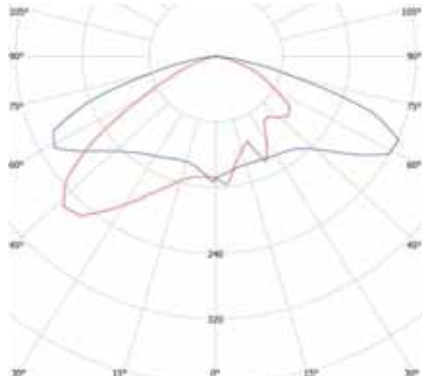

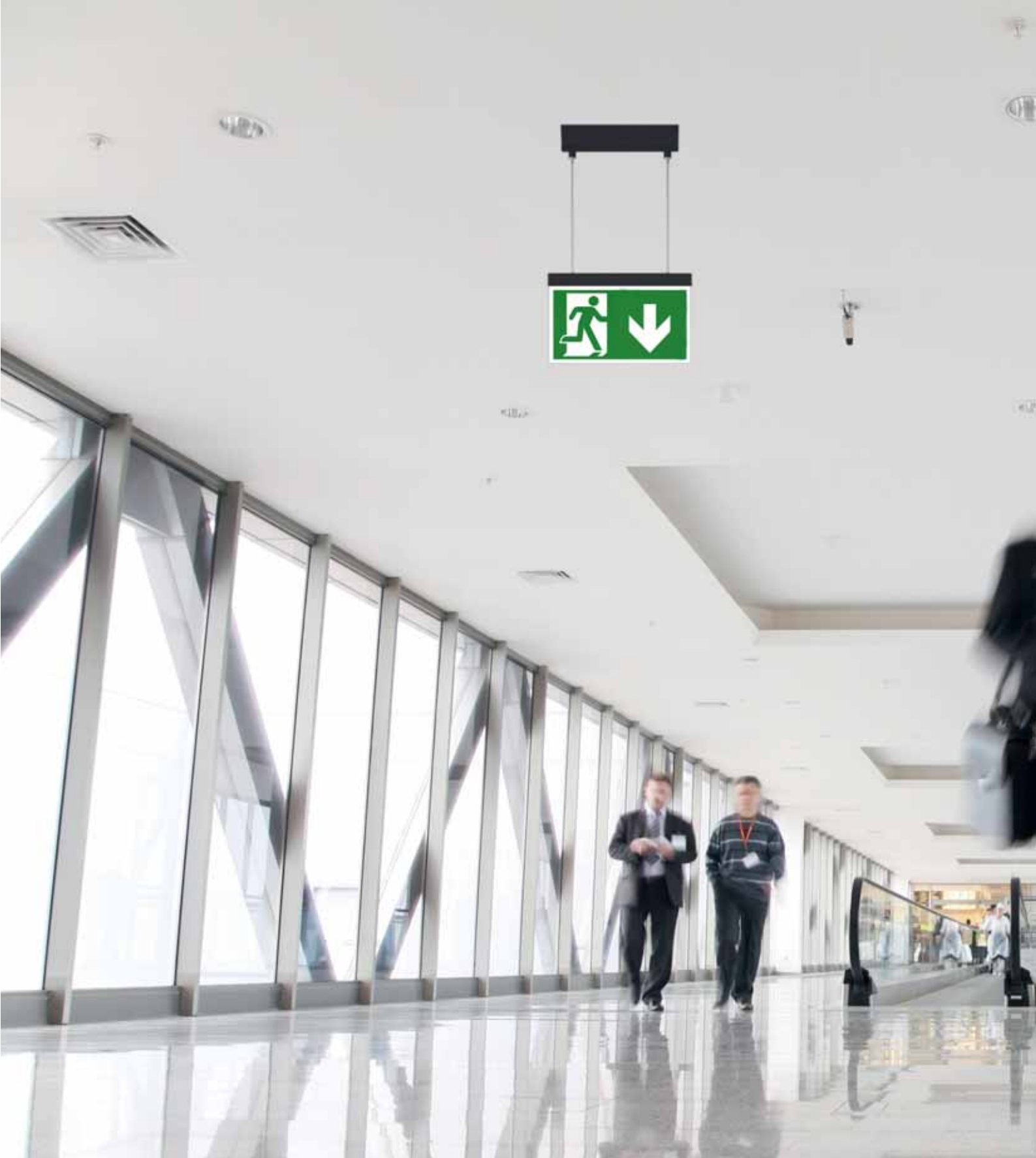

 **DESIGN LUMINAIRES**

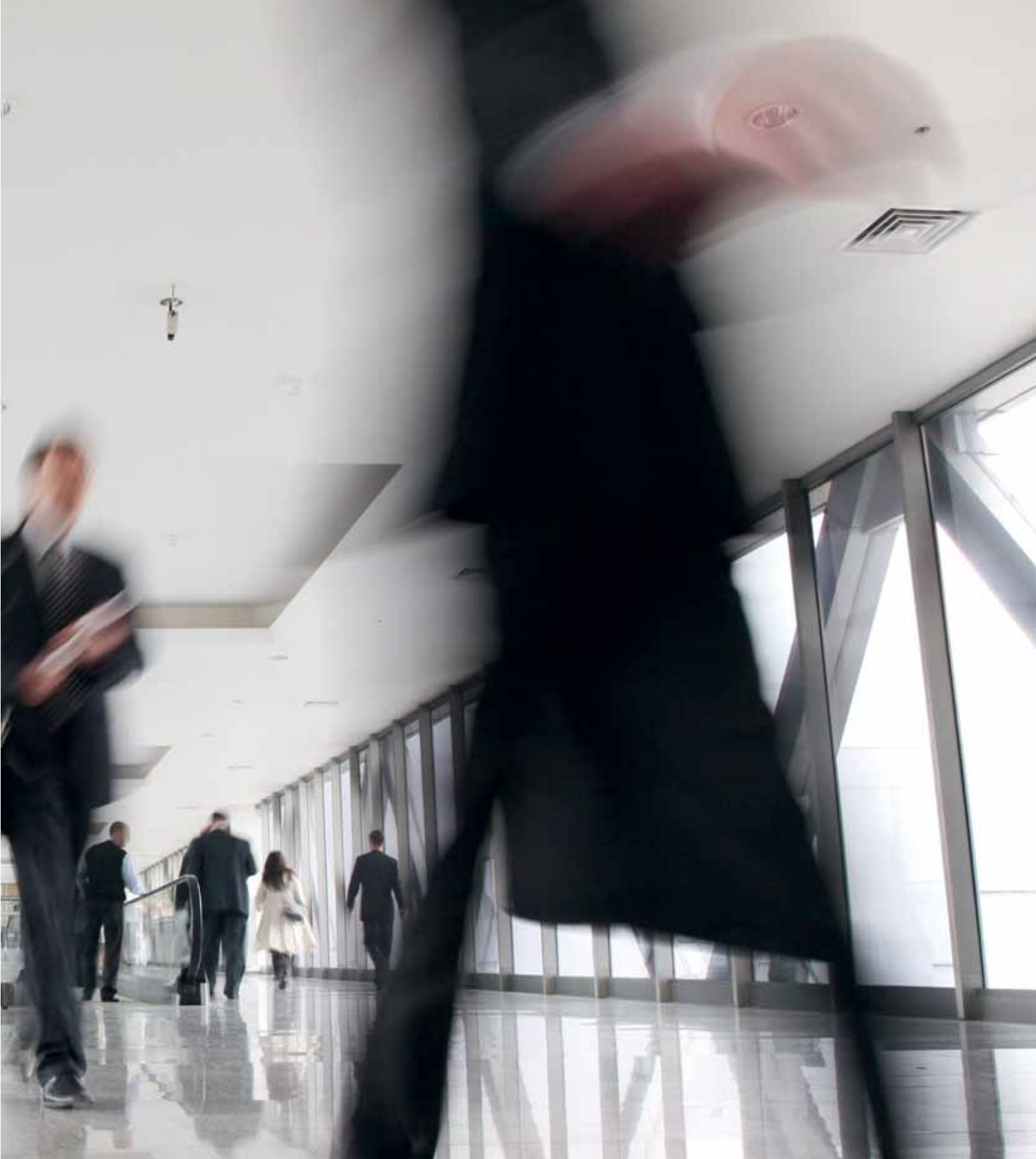



 **ASMU**
ALUMINIUM PROFILED EDGE LUMINAIRE



nicht für ASMU001(WL) und ASMU003(SC)



FACTS

- Aluminium profiled housing, silver or white
- 22m Viewing distance
- Complete set of pictographs (ISO 7010)
- IP40
- LED Illuminant
- Universal mounting
- -5° to +40°C

Innovative aluminum multifunctional edge LED luminaire for universal mounting (wall/ ceiling). Applicable for maintained or nonmaintained operation mode. Improved reliability through easy to install universal use of pictograms.

Pictogram set (left, right, straight up and down, blind) included. Signs according to EN 60598-1, EN 60598-2-22 and EN 1838 norms.



ASMU-W

ALUMINIUM PROFILED EDGE LUMINAIRE

	 	 					
SELF-CONTAINED LUMINAIRES WITH SELFCONTROL MODULE							
LED, 1h, 230V AC	ASMU411SC	ASMU411SC-WS	1 h		4,6 W	3,2V / 1,6 Ah LiFePO4	
LED, 3h, 230V AC	ASMU413SC	ASMU413SC-WS	3 h		4,6 W	3,2V / 1,6 Ah LiFePO4	
LED, 8h, 230V AC	ASMU418SC	ASMU418SC-WS	8 h		4,6 W	3,2V / 1,6 Ah LiFePO4	
SELF-CONTAINED LUMINAIRES WITH WIRELESS BASIC MODULE							
LED, 1h, 230V AC	ASMU411WB	ASMU411WB-WS	1 h		5,3 W	3,2V / 1,6 Ah LiFePO4	
LED, 3h, 230V AC	ASMU413WB	ASMU413WB-WS	3 h		5,3 W	3,2V / 1,6 Ah LiFePO4	
LED, 8h, 230V AC	ASMU418WB	ASMU418WB-WS	8 h		5,3 W	3,2V / 1,6 Ah LiFePO4	
SELF-CONTAINED LUMINAIRES WITH WIRELESS PROFESSIONAL MODULE (SWITCHABLE)							
LED, 1h, 230V AC	ASMU411WL	ASMU411WL-WS	1 h		5,3 W	3,2V / 1,6 Ah LiFePO4	
LED, 3h, 230V AC	ASMU413WL	ASMU413WL-WS	3 h		5,3 W	3,2V / 1,6 Ah LiFePO4	
LED, 8h, 230V AC	ASMU418WL	ASMU418WL-WS	8 h		5,3 W	3,2V / 1,6 Ah LiFePO4	
LUMINAIRES FOR CORE COMPACT LOW-POWER SYSTEMS 24V AC/DC INCL. MONITORING MODULE							
LED, 24V, AC/DC	ASMU519CC	ASMU519CC-WS	CPS		2,1 W		
LUMINAIRES FOR CENTRAL BATTERY SYSTEMS AC/DC INCL. MONITORING MODULE							
LED, 230V AC/DC	ASMU019ML	ASMU019ML-WS	CPS		3,2 W		



not for ASMU001(WL) and ASMU003(SC)



UNIVERSAL MOUNTING

Dimensions ASMU

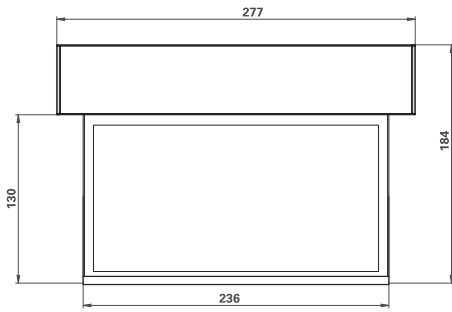

Drilling distances ASMU

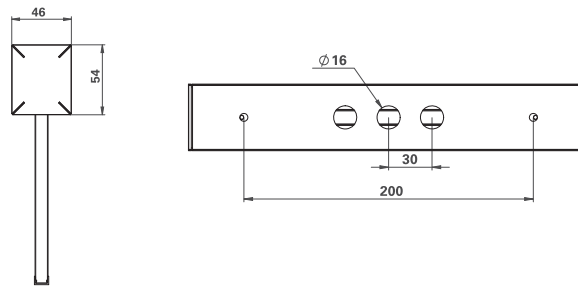

ACCESSORIES





 **A-Series**
DESIGN METAL EDGE LUMINAIRES



FACTS

- Zinc die-cast housing
Standard white (RAL 9003),
anthracite (-AZ) (RAL 7016)
or stainless steel look (-E)
- 15m (AI), 22m (AM), 30m (AX) or
50m (AG) Viewing distance
- Complete set of pictographs
(ISO 7010) (not for AG)
- IP20 (recessed, IP40 room side) or
IP40 (surface)
- LED Illuminant
- Wall or ceiling mounting
- -5° to +40°C

The A-series is a complete product line of high quality exit signs with metal housing for surface or recessed mounting. The entire series has been designed in the same style and can be perfectly integrated into any environment.

The A-series is characterized by sober, clear lines and is only noticeable when it comes to the worst.

The installation of the Zinc die-cast luminaires is simple. All clamps and screw connections are easily accessible at all times.

All luminaires of the A series are available in 4 sizes. The AM offers a detection range of 22m, while the larger AX has a detection range of 30m.

The uniform illumination of the pictogram is ensured by a dot matrix grid printed on the screen.

The type of mounting of the luminaire is indicated by the 3rd and, if appropriate, the fourth letter of the order number.

The luminaires with duo technology offer a light output downwards by means of an additional LED on the electronics housing. These luminaires are therefore perfect for illuminating the area of doors and passages. In normal operation, the pictogram is illuminated using conventional high power LEDs. In emergency operation, an automatic switchover to the integrated ERT LED is performed to illuminate the escape route and the pictogram.

All A-series luminaires are available as standard in white or in anthracite and with stainless-steel look.

The LED exit signs are built according to DIN EN 60598-1, DIN EN 60598-2-22, DIN EN 7010 and DIN EN 1838.





RECESSED CEILING MOUNTING - CIRCULAR CUT-OUT



AI - VIEWING DISTANCE 15M

SELF-CONTAINED LUMINAIRES WITH SELFCONTROL MODULE							
LED, 1h, 230V AC	AIE401SC	AIE401SC-AZ	AIE401SC-E	1 h	3,5 W	6,4V/1,2Ah LiFeP04	
LED, 3h, 230V AC	AIE403SC	AIE403SC-AZ	AIE403SC-E	3 h	3,5 W	6,4V/1,2Ah LiFeP04	
SELF-CONTAINED LUMINAIRES WITH WIRELESS PROFESSIONAL MODULE (SWITCHABLE)							
LED, 1h, 230V AC	AIE401WL	AIE401WL-AZ	AIE401WL-E	1 h	3,7 W	6,4V/1,2Ah LiFeP04	
LED, 3h, 230V AC	AIE403WL	AIE403WL-AZ	AIE403WL-E	3 h	3,7 W	6,4V/1,2Ah LiFeP04	
LED, 8h, 230V AC	AIE408WL	AIE408WL-AZ	AIE408WL-E	8 h	3,7 W	6,4V/1,2Ah LiFeP04	
LUMINAIRES FOR CORE COMPACT LOW-POWER SYSTEMS 24V AC/DC INCL. MONITORING MODULE							
LED, 24V, AC/DC	AIE509CC	AIE509CC-AZ	AIE509CC-E	CPS	1,7 W		
LUMINAIRES FOR CENTRAL BATTERY SYSTEMS AC/DC INCL. MONITORING MODULE							
LED, 230V AC/DC	AIE009ML	AIE009ML-AZ	AIE009ML-E	CPS	2,25 W		

RECESSED CEILING MOUNTING

Dimensions AI recessed ceiling mounting AIE

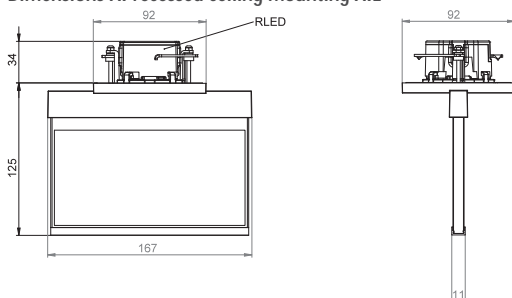

Self-contained electronics box (UH-1)

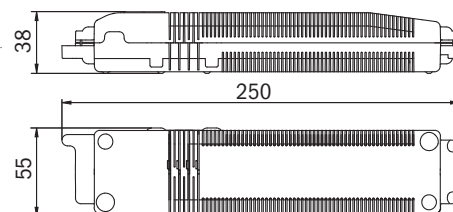



GERMAN DESIGN AWARD WINNER 2018



AI EP

GENERAL INFORMATIONS

RECESSED CEILING MOUNTING WITH PENDULUM - CIRCULAR CUT-OUT

DESIGN LUMINAIRES

DYNAMIC LUMINAIRES

UNIVERSAL LUMINAIRES

INDUSTRIAL LUMINAIRES

GENERAL LIGHTING WITH EMERGENCY LIGHT

WIRELESS MONITORING

ACCESSORIES

MODULES



AI - VIEWING DISTANCE 15M

SELF-CONTAINED LUMINAIRES WITH SELFCONTROL MODULE							
LED, 1h, 230V AC	AIEP401SC	AIEP401SC-AZ	AIEP401SC-E	1 h	3,5 W	6,4V/1,2Ah LiFeP04	
LED, 3h, 230V AC	AIEP403SC	AIEP403SC-AZ	AIEP403SC-E	3 h	3,5 W	6,4V/1,2Ah LiFeP04	
SELF-CONTAINED LUMINAIRES WITH WIRELESS PROFESSIONAL MODULE (SWITCHABLE)							
LED, 1h, 230V AC	AIEP401WL	AIEP401WL-AZ	AIEP401WL-E	1 h	3,7 W	6,4V/1,2Ah LiFeP04	
LED, 3h, 230V AC	AIEP403WL	AIEP403WL-AZ	AIEP403WL-E	3 h	3,7 W	6,4V/1,2Ah LiFeP04	
LED, 8h, 230V AC	AIEP408WL	AIEP408WL-AZ	AIEP408WL-E	8 h	3,7 W	6,4V/1,2Ah LiFeP04	
LUMINAIRES FOR CORE COMPACT LOW-POWER SYSTEMS 24V AC/DC INCL. MONITORING MODULE							
LED, 24V, AC/DC	AIEP509CC	AIEP509CC-AZ	AIEP509CC-E	CPS	1,7 W		
LUMINAIRES FOR CENTRAL BATTERY SYSTEMS AC/DC INCL. MONITORING MODULE							
LED, 230V AC/DC	AIEP009ML	AIEP009ML-AZ	AIEP009ML-E	CPS	2,25 W		

RECESSED CEILING MOUNTING

Dimensions AI recessed ceiling mounting AIEP

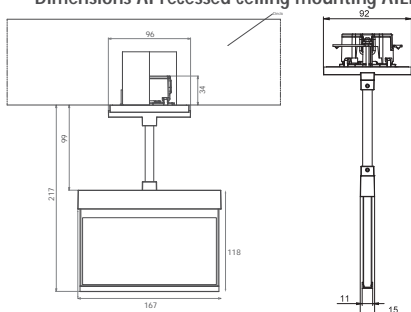

Self-contained electronics box (UH-1)

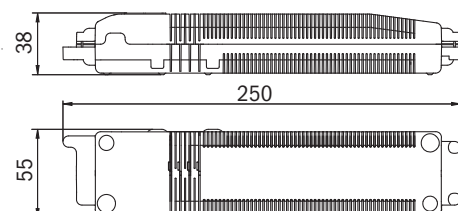

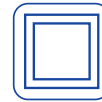

RECESSED WALL MOUNTING CIRCULAR CUT-OUT



AI – VIEWING DISTANCE 15M

SELF-CONTAINED LUMINAIRES WITH SELFCONTROL MODULE							
LED, 1h, 230V AC	AIR401SC	AIR401SC-AZ	AIR401SC-E	1 h	3,5 W	6,4V/1,2Ah LiFeP04	
LED, 3h, 230V AC	AIR403SC	AIR403SC-AZ	AIR403SC-E	3 h	3,5 W	6,4V/1,2Ah LiFeP04	
LED, 8h, 230V AC	AIR408SC	AIR408SC-AZ	AIR408SC-E	8 h	3,7 W	6,4V/1,2Ah LiFeP04	
LUMINAIRES FOR CORE COMPACT LOW-POWER SYSTEMS 24V AC/DC INCL. MONITORING MODULE							
LED, 24V, AC/DC	AIR509CC	AIR509CC-AZ	AIR509CC-E	CPS	1,7 W		
LUMINAIRES FOR CENTRAL BATTERY SYSTEMS AC/DC INCL. MONITORING MODULE							
LED, 230V AC/DC	AIR009ML	AIR009ML-AZ	AIR009ML-E	CPS	2,25 W		

RECESSED WALL MOUNTING

Dimensions AI Recessed wall mounting AIR



Self-contained electronics box (UH-1)

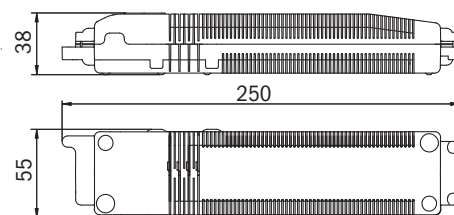



WALL MOUNTING



AI - VIEWING DISTANCE 15M

SELF-CONTAINED LUMINAIRES WITH SELFCONTROL MODULE							
LED, 1h, 230V AC	AIW401SC	AIW401SC-AZ	AIW401SC-E	1 h	3,5 W	6,4V/1,2Ah LiFeP04	
LED, 3h, 230V AC	AIW403SC	AIW403SC-AZ	AIW403SC-E	3 h	3,5 W	6,4V/1,2Ah LiFeP04	
LED, 8h, 230V AC	AIW408SC	AIW408SC-AZ	AIW408SC-E	8 h	3,7 W	6,4V/1,2Ah LiFeP04	
SELF-CONTAINED LUMINAIRES WITH WIRELESS PROFESSIONAL MODULE (SWITCHABLE)							
LED, 1h, 230V AC	AIW401WL	AIW401WL-AZ	AIW401WL-E	1 h	3,7 W	6,4V/1,2Ah LiFeP04	
LED, 3h, 230V AC	AIW403WL	AIW403WL-AZ	AIW403WL-E	3 h	3,7 W	6,4V/1,2Ah LiFeP04	
LED, 8h, 230V AC	AIW408WL	AIW408WL-AZ	AIW408WL-E	8 h	3,7 W	6,4V/1,2Ah LiFeP04	
LUMINAIRES FOR CORE COMPACT LOW-POWER SYSTEMS 24V AC/DC INCL. MONITORING MODULE							
LED, 24V, AC/DC	AIW509CC	AIW509CC-AZ	AIW509CC-E	CPS	1,7 W		
LUMINAIRES FOR CENTRAL BATTERY SYSTEMS AC/DC INCL. MONITORING MODULE							
LED, 230V, AC/DC	AIW009ML	AIW009ML-AZ	AIW009ML-E	CPS	3 W		

WALL MOUNTING

Dimensions wall mounting AIW

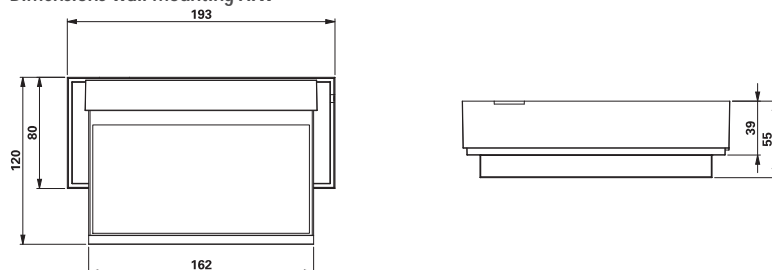



WALL MOUNTING



AM – VIEWING DISTANCE 22M

<div style="display: flex; justify-content: space-around; align-items: center;"> <div style="width: 20px; height: 10px; background-color: white; border: 1px solid black;"></div> <div style="width: 20px; height: 10px; background-color: black; border: 1px solid black;"></div> <div style="width: 20px; height: 10px; background-color: gray; border: 1px solid black;"></div> </div>							
SELF-CONTAINED LUMINAIRES WITH SELFCONTROL MODULE							
LED, 1h, 230V AC	AMW401SC	AMW401SC-AZ	AMW401SC-E	1 h	4,3 W	6,4V/1,2Ah LiFeP04	
LED, 3h, 230V AC	AMW403SC	AMW403SC-AZ	AMW403SC-E	3 h	4,3 W	6,4V/1,2Ah LiFeP04	
LED, 8h, 230V AC	AMW408SC	AMW408SC-AZ	AMW408SC-E	8 h	4,3 W	6,4V/1,2Ah LiFeP04	
SELF-CONTAINED LUMINAIRES WITH WIRELESS PROFESSIONAL MODULE (SWITCHABLE)							
LED, 1h, 230V AC	AMW401WL	AMW401WL-AZ	AMW401WL-E	1 h	4,7 W	6,4V/1,2Ah LiFeP04	
LED, 3h, 230V AC	AMW403WL	AMW403WL-AZ	AMW403WL-E	3 h	4,7 W	6,4V/1,2Ah LiFeP04	
LED, 8h, 230V AC	AMW408WL	AMW408WL-AZ	AMW408WL-E	8 h	4,7 W	6,4V/1,2Ah LiFeP04	
LUMINAIRES FOR CORE COMPACT LOW-POWER SYSTEMS 24V AC/DC INCL. MONITORING MODULE							
LED, 24V, AC/DC	AMW509CC	AMW509CC-AZ	AMW509CC-E	CPS	2,6 W		
LUMINAIRES FOR CENTRAL BATTERY SYSTEMS AC/DC							
LED, 230V AC/DC	AMW009	AMW009-AZ	AMW009-E	CPS	2,4 W		
LUMINAIRES FOR CENTRAL BATTERY SYSTEMS AC/DC INCL. MONITORING MODULE							
LED, 230V AC/DC	AMW009ML	AMW009ML-AZ	AMW009ML-E	CPS	3,5 W		



AX W

GENERAL INFORMATION

WALL MOUNTING

DESIGN LUMINAIRES

DYNAMIC LUMINAIRES

UNIVERSAL LUMINAIRES

INDUSTRIAL LUMINAIRES

GENERAL LIGHTING WITH EMERGENCY LIGHT

WIRELESS MONITORING

ACCESSORIES

MODULES



AX – VIEWING DISTANCE 30M

SELF-CONTAINED LUMINAIRES WITH SELFCONTROL MODULE							
LED, 1h, 230V AC	AXW401SC	AXW401SC-AZ	AXW401SC-E	1 h	4,2 W	6,4V/1,2Ah LiFeP04	
LED, 3h, 230V AC	AXW403SC	AXW403SC-AZ	AXW403SC-E	3 h	4,2 W	6,4V/1,2Ah LiFeP04	
LED, 8h, 230V AC	AXW408SC	AXW408SC-AZ	AXW408SC-E	8 h	4,2 W	6,4V/1,2Ah LiFeP04	
SELF-CONTAINED LUMINAIRES WITH WIRELESS PROFESSIONAL MODULE (SWITCHABLE)							
LED, 1h, 230V AC	AXW401WL	AXW401WL-AZ	AXW401WL-E	1 h	5,6 W	6,4V/1,2Ah LiFeP04	
LED, 3h, 230V AC	AXW403WL	AXW403WL-AZ	AXW403WL-E	3 h	5,6 W	6,4V/1,2Ah LiFeP04	
LED, 8h, 230V AC	AXW408WL	AXW408WL-AZ	AXW408WL-E	8 h	5,6 W	6,4V/1,2Ah LiFeP04	
LUMINAIRES FOR CORE COMPACT LOW-POWER SYSTEMS 24V AC/DC INCL. MONITORING MODULE							
LED, 230V AC/DC	AXW509CC	AXW509CC-AZ	AXW509CC-E	CPS	3,7 W		
LUMINAIRES FOR CENTRAL BATTERY SYSTEMS AC/DC							
LED, 230V AC/DC	AXW009	AXW009-AZ	AXW009-E	CPS	3,3 W		
LUMINAIRES FOR CENTRAL BATTERY SYSTEMS AC/DC INCL. MONITORING MODULE							
LED, 230V AC/DC	AXW009ML	AXW009ML-AZ	AXW009ML-E	CPS	4,5 W		



RECESSED WALL MOUNTING



AM – VIEWING DISTANCE 22M

SELF-CONTAINED LUMINAIRES WITH SELFCONTROL MODULE							
LED, 1h, 230V AC	AMR401SC	AMR401SC-AZ	AMR401SC-E	1 h	4,3 W	6,4V/1,2Ah LiFeP04	
LED, 3h, 230V AC	AMR403SC	AMR403SC-AZ	AMR403SC-E	3 h	4,3 W	6,4V/1,2Ah LiFeP04	
LED, 8h, 230V AC	AMR408SC	AMR408SC-AZ	AMR408SC-E	8 h	4,3 W	6,4V/1,2Ah LiFeP04	
SELF-CONTAINED LUMINAIRES WITH WIRELESS PROFESSIONAL MODULE (SWITCHABLE)							
LED, 1h, 230V AC	AMR401WL	AMR401WL-AZ	AMR401WL-E	1 h	4,7 W	6,4V/1,2Ah LiFeP04	
LED, 3h, 230V AC	AMR403WL	AMR403WL-AZ	AMR403WL-E	3 h	4,7 W	6,4V/1,2Ah LiFeP04	
LED, 8h, 230V AC	AMR408WL	AMR408WL-AZ	AMR408WL-E	8 h	4,7 W	6,4V/1,2Ah LiFeP04	
LUMINAIRES FOR CORE COMPACT LOW-POWER SYSTEMS 24V AC/DC INCL. MONITORING MODULE							
LED, 24V, AC/DC	AMR509CC	AMR509CC-AZ	AMR509CC-E	CPS	2,6 W		
LUMINAIRES FOR CENTRAL BATTERY SYSTEMS AC/DC							
LED, 230V AC/DC	AMR009	AMR009-AZ	AMR009-E	CPS	2,4 W		
LUMINAIRES FOR CENTRAL BATTERY SYSTEMS AC/DC INCL. MONITORING MODULE							
LED, 230V AC/DC	AMR009ML	AMR009ML-AZ	AMR009ML-E	CPS	3,5 W		



AX R

GENERAL INFORMATION

RECESSED WALL MOUNTING



DESIGN LUMINAIRES

DYNAMIC LUMINAIRES

UNIVERSAL LUMINAIRES

AX – VIEWING DISTANCE 30M

SELF-CONTAINED LUMINAIRES WITH SELFCONTROL MODULE							
LED, 1h, 230V AC	AXR401SC	AXR401SC-AZ	AXR401SC-E	1 h	4,2 W	6,4V/1,2Ah LiFeP04	
LED, 3h, 230V AC	AXR403SC	AXR403SC-AZ	AXR403SC-E	3 h	4,2 W	6,4V/1,2Ah LiFeP04	
LED, 8h, 230V AC	AXR408SC	AXR408SC-AZ	AXR408SC-E	8 h	4,2 W	6,4V/1,2Ah LiFeP04	
SELF-CONTAINED LUMINAIRES WITH WIRELESS PROFESSIONAL MODULE (SWITCHABLE)							
LED, 1h, 230V AC	AXR401WL	AXR401WL-AZ	AXR401WL-E	1 h	5,6 W	6,4V/1,2Ah LiFeP04	
LED, 3h, 230V AC	AXR403WL	AXR403WL-AZ	AXR403WL-E	3 h	5,6 W	6,4V/1,2Ah LiFeP04	
LED, 8h, 230V AC	AXR408WL	AXR408WL-AZ	AXR408WL-E	8 h	5,6 W	6,4V/1,2Ah LiFeP04	
LUMINAIRES FOR CORE COMPACT LOW-POWER SYSTEMS 24V AC/DC INCL. MONITORING MODULE							
LED, 24V, AC/DC	AXR509CC	AXR509CC-AZ	AXR509CC-E	CPS	3,7 W		
LUMINAIRES FOR CENTRAL BATTERY SYSTEMS AC/DC							
LED, 230V AC/DC	AXR009	AXR009-AZ	AXR009-E	CPS	3,3 W		
LUMINAIRES FOR CENTRAL BATTERY SYSTEMS AC/DC INCL. MONITORING MODULE							
LED, 230V AC/DC	AXR009ML	AXR009ML-AZ	AXR009ML-E	CPS	4,5 W		

INDUSTRIAL LUMINAIRES

GENERAL LIGHTING WITH EMERGENCY LIGHT

WIRELESS MONITORING

ACCESSORIES

MODULES

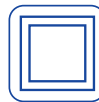

CEILING MOUNTING



AM – VIEWING DISTANCE 22M

SELF-CONTAINED LUMINAIRES WITH SELFCONTROL MODULE							
LED, 1h, 230V AC	AMD401SC	AMD401SC-AZ	AMD401SC-E	1 h	4,3 W	6,4V/1,2Ah LiFeP04	
LED, 3h, 230V AC	AMD403SC	AMD403SC-AZ	AMD403SC-E	3 h	4,3 W	6,4V/1,2Ah LiFeP04	
LED, 8h, 230V AC	AMD408SC	AMD408SC-AZ	AMD408SC-E	8 h	4,3 W	6,4V/1,2Ah LiFeP04	
SELF-CONTAINED LUMINAIRES WITH WIRELESS PROFESSIONAL MODULE (SWITCHABLE)							
LED, 1h, 230V AC	AMD401WL	AMD401WL-AZ	AMD401WL-E	1 h	4,7 W	6,4V/1,2Ah LiFeP04	
LED, 3h, 230V AC	AMD403WL	AMD403WL-AZ	AMD403WL-E	3 h	4,7 W	6,4V/1,2Ah LiFeP04	
LED, 8h, 230V AC	AMD408WL	AMD408WL-AZ	AMD408WL-E	8 h	4,7 W	6,4V/1,2Ah LiFeP04	
LUMINAIRES FOR CORE COMPACT LOW-POWER SYSTEMS 24V AC/DC INCL. MONITORING MODULE							
LED, 24V, AC/DC	AMD509CC	AMD509CC-AZ	AMD509CC-E	CPS	2,6 W		
LUMINAIRES FOR CENTRAL BATTERY SYSTEMS AC/DC							
LED, 230V AC/DC	AMD009	AMD009-AZ	AMD009-E	CPS	2,4 W		
LUMINAIRES FOR CENTRAL BATTERY SYSTEMS AC/DC INCL. MONITORING MODULE							
LED, 230V AC/DC	AMD009ML	AMD009ML-AZ	AMD009ML-E	CPS	3,5 W		



CEILING MOUNTING



AX – VIEWING DISTANCE 30M

SELF-CONTAINED LUMINAIRES WITH SELFCONTROL MODULE							
LED, 1h, 230V AC	AXD401SC	AXD401SC-AZ	AXD401SC-E	1 h	4,2 W	6,4V/1,2Ah LiFeP04	
LED, 3h, 230V AC	AXD403SC	AXD403SC-AZ	AXD403SC-E	3 h	4,2 W	6,4V/1,2Ah LiFeP04	
LED, 8h, 230V AC	AXD408SC	AXD408SC-AZ	AXD408SC-E	8 h	4,2 W	6,4V/1,2Ah LiFeP04	
SELF-CONTAINED LUMINAIRES WITH WIRELESS PROFESSIONAL MODULE (SWITCHABLE)							
LED, 1h, 230V AC	AXD401WL	AXD401WL-AZ	AXD401WL-E	1 h	5,6 W	6,4V/1,2Ah LiFeP04	
LED, 3h, 230V AC	AXD403WL	AXD403WL-AZ	AXD403WL-E	3 h	5,6 W	6,4V/1,2Ah LiFeP04	
LED, 8h, 230V AC	AXD408WL	AXD408WL-AZ	AXD408WL-E	8 h	5,6 W	6,4V/1,2Ah LiFeP04	
LUMINAIRES FOR CORE COMPACT LOW-POWER SYSTEMS 24V AC/DC INCL. MONITORING MODULE							
LED, 24V, AC/DC	AXD509CC	AXD509CC-AZ	AXD509CC-E	CPS	3,7 W		
LUMINAIRES FOR CENTRAL BATTERY SYSTEMS AC/DC							
LED, 230V AC/DC	AXD009	AXD009-AZ	AXD009-E	CPS	3,3 W		
LUMINAIRES FOR CENTRAL BATTERY SYSTEMS AC/DC INCL. MONITORING MODULE							
LED, 230V AC/DC	AXD009ML	AXD009ML-AZ	AXD009ML-E	CPS	4,5 W		



RECESSED CEILING MOUNTING



AM – VIEWING DISTANCE 22M

SELF-CONTAINED LUMINAIRES WITH SELFCONTROL MODULE									
LED, 1h, 230V AC	AMC401SC	AMC401SC-AZ	AMC401SC-E	1 h	4,3 W	6,4V/1,2Ah LiFeP04			
LED, 3h, 230V AC	AMC403SC	AMC403SC-AZ	AMC403SC-E	3 h	4,3 W	6,4V/1,2Ah LiFeP04			
LED, 8h, 230V AC	AMC408SC	AMC408SC-AZ	AMC408SC-E	8 h	4,3 W	6,4V/1,2Ah LiFeP04			
SELF-CONTAINED LUMINAIRES WITH WIRELESS PROFESSIONAL MODULE (SWITCHABLE)									
LED, 1h, 230V AC	AMC401WL	AMC401WL-AZ	AMC401WL-E	1 h	4,7 W	6,4V/1,2Ah LiFeP04			
LED, 3h, 230V AC	AMC403WL	AMC403WL-AZ	AMC403WL-E	3 h	4,7 W	6,4V/1,2Ah LiFeP04			
LED, 8h, 230V AC	AMC408WL	AMC408WL-AZ	AMC408WL-E	8 h	4,7 W	6,4V/1,2Ah LiFeP04			
LUMINAIRES FOR CORE COMPACT LOW-POWER SYSTEMS 24V AC/DC INCL. MONITORING MODULE									
LED, 24V, AC/DC	AMC509CC	AMC509CC-AZ	AMC509CC-E	CPS	2,6 W				
LUMINAIRES FOR CENTRAL BATTERY SYSTEMS AC/DC									
LED, 230V AC/DC	AMC009	AMC009-AZ	AMC009-E	CPS	2,4 W				
LUMINAIRES FOR CENTRAL BATTERY SYSTEMS AC/DC INCL. MONITORING MODULE									
LED, 230V AC/DC	AMC009ML	AMC009ML-AZ	AMC009ML-E	CPS	3,5 W				



RECESSED CEILING MOUNTING



AX – VIEWING DISTANCE 30M

SELF-CONTAINED LUMINAIRES WITH SELFCONTROL MODULE							
LED, 1h, 230V AC	AXC401SC	AXC401SC-AZ	AXC401SC-E	1 h	4,2 W	6,4V/1,2Ah LiFeP04	
LED, 3h, 230V AC	AXC403SC	AXC403SC-AZ	AXC403SC-E	3 h	4,2 W	6,4V/1,2Ah LiFeP04	
LED, 8h, 230V AC	AXC408SC	AXC408SC-AZ	AXC408SC-E	8 h	4,2 W	6,4V/1,2Ah LiFeP04	
SELF-CONTAINED LUMINAIRES WITH WIRELESS PROFESSIONAL MODULE (SWITCHABLE)							
LED, 1h, 230V AC	AXC401WL	AXC401WL-AZ	AXC401WL-E	1 h	5,6 W	6,4V/1,2Ah LiFeP04	
LED, 3h, 230V AC	AXC403WL	AXC403WL-AZ	AXC403WL-E	3 h	5,6 W	6,4V/1,2Ah LiFeP04	
LED, 8h, 230V AC	AXC408WL	AXC408WL-AZ	AXC408WL-E	8 h	5,6 W	6,4V/1,2Ah LiFeP04	
LUMINAIRES FOR CORE COMPACT LOW-POWER SYSTEMS 24V AC/DC INCL. MONITORING MODULE							
LED, 24V, AC/DC	AXC509CC	AXC509CC-AZ	AXC509CC-E	CPS	3,7 W		
LUMINAIRES FOR CENTRAL BATTERY SYSTEMS AC/DC							
LED, 230V AC/DC	AXC009	AXC009-AZ	AXC009-E	CPS	3,3 W		
LUMINAIRES FOR CENTRAL BATTERY SYSTEMS AC/DC INCL. MONITORING MODULE							
LED, 230V AC/DC	AXC009ML	AXC009ML-AZ	AXC009ML-E	CPS	4,5 W		



RECESSED CEILING MOUNTING WITH CORD SUSPENSION



AM – VIEWING DISTANCE 22M

SELF-CONTAINED LUMINAIRES WITH SELFCONTROL MODULE							
LED, 1h, 230V AC	AMCC401SC	AMCC401SC-AZ	AMCC401SC-E	1 h	4,3 W	6,4V/1,2Ah LiFeP04	
LED, 3h, 230V AC	AMCC403SC	AMCC403SC-AZ	AMCC403SC-E	3 h	4,3 W	6,4V/1,2Ah LiFeP04	
LED, 8h, 230V AC	AMCC408SC	AMCC408SC-AZ	AMCC408SC-E	8 h	4,3 W	6,4V/1,2Ah LiFeP04	
SELF-CONTAINED LUMINAIRES WITH WIRELESS PROFESSIONAL MODULE (SWITCHABLE)							
LED, 1h, 230V AC	AMCC401WL	AMCC401WL-AZ	AMCC401WL-E	1 h	4,7 W	6,4V/1,2Ah LiFeP04	
LED, 3h, 230V AC	AMCC403WL	AMCC403WL-AZ	AMCC403WL-E	3 h	4,7 W	6,4V/1,2Ah LiFeP04	
LED, 8h, 230V AC	AMCC408WL	AMCC408WL-AZ	AMCC408WL-E	8 h	4,7 W	6,4V/1,2Ah LiFeP04	
LUMINAIRES FOR CORE COMPACT LOW-POWER SYSTEMS 24V AC/DC INCL. MONITORING MODULE							
LED, 24V, AC/DC	AMCC509CC	AMCC509CC-AZ	AMCC509CC-E	CPS	2,6 W		
LUMINAIRES FOR CENTRAL BATTERY SYSTEMS AC/DC							
LED, 230V AC/DC	AMCC009	AMCC009-AZ	AMCC009-E	CPS	2,4 W		
LUMINAIRES FOR CENTRAL BATTERY SYSTEMS AC/DC INCL. MONITORING MODULE							
LED, 230V AC/DC	AMCC009ML	AMCC009ML-AZ	AMCC009ML-E	CPS	3,5 W		



GERMAN DESIGN AWARD WINNER 2018



AX CC

GENERAL INFORMATIONS

RECESSED CEILING MOUNTING WITH CORD SUSPENSION



DESIGN LUMINAIRES

DYNAMIC LUMINAIRES

UNIVERSAL LUMINAIRES

AX – VIEWING DISTANCE 30M

SELF-CONTAINED LUMINAIRES WITH SELFCONTROL MODULE							
LED, 1h, 230V AC	AXCC401SC	AXCC401SC-AZ	AXCC401SC-E	1 h	4,2 W	6,4V/1,2Ah LiFeP04	
LED, 3h, 230V AC	AXCC403SC	AXCC403SC-AZ	AXCC403SC-E	3 h	4,2 W	6,4V/1,2Ah LiFeP04	
LED, 8h, 230V AC	AXCC408SC	AXCC408SC-AZ	AXCC408SC-E	8 h	4,2 W	6,4V/1,2Ah LiFeP04	
SELF-CONTAINED LUMINAIRES WITH WIRELESS PROFESSIONAL MODULE (SWITCHABLE)							
LED, 1h, 230V AC	AXCC401WL	AXCC401WL-AZ	AXCC401WL-E	1 h	5,6 W	6,4V/1,2Ah LiFeP04	
LED, 3h, 230V AC	AXCC403WL	AXCC403WL-AZ	AXCC403WL-E	3 h	5,6 W	6,4V/1,2Ah LiFeP04	
LED, 8h, 230V AC	AXCC408WL	AXCC408WL-AZ	AXCC408WL-E	8 h	5,6 W	6,4V/1,2Ah LiFeP04	
LUMINAIRES FOR CORE COMPACT LOW-POWER SYSTEMS 24V AC/DC INCL. MONITORING MODULE							
LED, 24V, AC/DC	AXCC509CC	AXCC509CC-AZ	AXCC509CC-E	CPS	3,7 W		
LUMINAIRES FOR CENTRAL BATTERY SYSTEMS AC/DC							
LED, 230V AC/DC	AXCC009	AXCC009-AZ	AXCC009-E	CPS	3,3 W		
LUMINAIRES FOR CENTRAL BATTERY SYSTEMS AC/DC INCL. MONITORING MODULE							
LED, 230V AC/DC	AXCC009ML	AXCC009ML-AZ	AXCC009ML-E	CPS	4,5 W		

INDUSTRIAL LUMINAIRES

GENERAL LIGHTING WITH EMERGENCY LIGHT

WIRELESS MONITORING

ACCESSORIES

MODULES



CEILING MOUNTING WITH CORD SUSPENSION



AM – VIEWING DISTANCE 22M

SELF-CONTAINED LUMINAIRES WITH SELFCONTROL MODULE							
LED, 1h, 230V AC	AMDC401SC	AMDC401SC-AZ	AMDC401SC-E	1 h	4,3 W	6,4V/1,2Ah LiFeP04	
LED, 3h, 230V AC	AMDC403SC	AMDC403SC-AZ	AMDC403SC-E	3 h	4,3 W	6,4V/1,2Ah LiFeP04	
LED, 8h, 230V AC	AMDC408SC	AMDC408SC-AZ	AMDC408SC-E	8 h	4,3 W	6,4V/1,2Ah LiFeP04	
SELF-CONTAINED LUMINAIRES WITH WIRELESS PROFESSIONAL MODULE (SWITCHABLE)							
LED, 1h, 230V AC	AMDC401WL	AMDC401WL-AZ	AMDC401WL-E	1 h	4,7 W	6,4V/1,2Ah LiFeP04	
LED, 3h, 230V AC	AMDC403WL	AMDC403WL-AZ	AMDC403WL-E	3 h	4,7 W	6,4V/1,2Ah LiFeP04	
LED, 8h, 230V AC	AMDC408WL	AMDC408WL-AZ	AMDC408WL-E	8 h	4,7 W	6,4V/1,2Ah LiFeP04	
LUMINAIRES FOR CORE COMPACT LOW-POWER SYSTEMS 24V AC/DC INCL. MONITORING MODULE							
LED, 24V, AC/DC	AMDC509CC	AMDC509CC-AZ	AMDC509CC-E	CPS	2,6 W		
LUMINAIRES FOR CENTRAL BATTERY SYSTEMS AC/DC							
LED, 230V AC/DC	AMDC009	AMDC009-AZ	AMDC009-E	CPS	2,4 W		
LUMINAIRES FOR CENTRAL BATTERY SYSTEMS AC/DC INCL. MONITORING MODULE							
LED, 230V AC/DC	AMDC009ML	AMDC009ML-AZ	AMDC009ML-E	CPS	3,5 W		



CEILING MOUNTING WITH CORD SUSPENSION



AX – VIEWING DISTANCE 30M

SELF-CONTAINED LUMINAIRES WITH SELFCONTROL MODULE							
LED, 1h, 230V AC	AXDC401SC	AXDC401SC-AZ	AXDC401SC-E	1 h	4,2 W	6,4V/1,2Ah LiFeP04	
LED, 3h, 230V AC	AXDC403SC	AXDC403SC-AZ	AXDC403SC-E	3 h	4,2 W	6,4V/1,2Ah LiFeP04	
LED, 8h, 230V AC	AXDC408SC	AXDC408SC-AZ	AXDC408SC-E	8 h	4,2 W	6,4V/1,2Ah LiFeP04	
SELF-CONTAINED LUMINAIRES WITH WIRELESS PROFESSIONAL MODULE (SWITCHABLE)							
LED, 1h, 230V AC	AXDC401WL	AXDC401WL-AZ	AXDC401WL-E	1 h	5,6 W	6,4V/1,2Ah LiFeP04	
LED, 3h, 230V AC	AXDC403WL	AXDC403WL-AZ	AXDC403WL-E	3 h	5,6 W	6,4V/1,2Ah LiFeP04	
LED, 8h, 230V AC	AXDC408WL	AXDC408WL-AZ	AXDC408WL-E	8 h	5,6 W	6,4V/1,2Ah LiFeP04	
LUMINAIRES FOR CORE COMPACT LOW-POWER SYSTEMS 24V AC/DC INCL. MONITORING MODULE							
LED, 24V, AC/DC	AXDC509CC	AXDC509CC-AZ	AXDC509CC-E	CPS	3,7 W		
LUMINAIRES FOR CENTRAL BATTERY SYSTEMS AC/DC							
LED, 230V AC/DC	AXDC009	AXDC009-AZ	AXDC009-E	CPS	3,3 W		
LUMINAIRES FOR CENTRAL BATTERY SYSTEMS AC/DC INCL. MONITORING MODULE							
LED, 230V AC/DC	AXDC009ML	AXDC009ML-AZ	AXDC009ML-E	CPS	4,5 W		



RECESSED CEILING MOUNTING WITH PENDULUM



AM – VIEWING DISTANCE 22M

SELF-CONTAINED LUMINAIRES WITH SELFCONTROL MODULE							
LED, 1h, 230V AC	AMCP401SC	AMCP401SC-AZ	AMCP401SC-E	1 h	4,3 W	6,4V/1,2Ah LiFeP04	
LED, 3h, 230V AC	AMCP403SC	AMCP403SC-AZ	AMCP403SC-E	3 h	4,3 W	6,4V/1,2Ah LiFeP04	
LED, 8h, 230V AC	AMCP408SC	AMCP408SC-AZ	AMCP408SC-E	8 h	4,3 W	6,4V/1,2Ah LiFeP04	
SELF-CONTAINED LUMINAIRES WITH WIRELESS PROFESSIONAL MODULE (SWITCHABLE)							
LED, 1h, 230V AC	AMCP401WL	AMCP401WL-AZ	AMCP401WL-E	1 h	4,7 W	6,4V/1,2Ah LiFeP04	
LED, 3h, 230V AC	AMCP403WL	AMCP403WL-AZ	AMCP403WL-E	3 h	4,7 W	6,4V/1,2Ah LiFeP04	
LED, 8h, 230V AC	AMCP408WL	AMCP408WL-AZ	AMCP408WL-E	8 h	4,7 W	6,4V/1,2Ah LiFeP04	
LUMINAIRES FOR CORE COMPACT LOW-POWER SYSTEMS 24V AC/DC INCL. MONITORING MODULE							
LED, 24V, AC/DC	AMCP509CC	AMCP509CC-AZ	AMCP509CC-E	CPS	2,6 W		
LUMINAIRES FOR CENTRAL BATTERY SYSTEMS AC/DC							
LED, 230V AC/DC	AMCP009	AMCP009-AZ	AMCP009-E	CPS	2,4 W		
LUMINAIRES FOR CENTRAL BATTERY SYSTEMS AC/DC INCL. MONITORING MODULE							
LED, 230V AC/DC	AMCP009ML	AMCP009ML-AZ	AMCP009ML-E	CPS	3,5 W		



GERMAN DESIGN AWARD WINNER 2018



AX CP

GENERAL INFORMATION

RECESSED CEILING MOUNTING WITH PENDULUM



DESIGN LUMINAIRES

DYNAMIC LUMINAIRES

UNIVERSAL LUMINAIRES

AX – VIEWING DISTANCE 30M

SELF-CONTAINED LUMINAIRES WITH SELFCONTROL MODULE							
LED, 1h, 230V AC	AXCP401SC	AXCP401SC-AZ	AXCP401SC-E	1 h	4,2 W	6,4V/1,2Ah LiFeP04	
LED, 3h, 230V AC	AXCP403SC	AXCP403SC-AZ	AXCP403SC-E	3 h	4,2 W	6,4V/1,2Ah LiFeP04	
LED, 8h, 230V AC	AXCP408SC	AXCP408SC-AZ	AXCP408SC-E	8 h	4,2 W	6,4V/1,2Ah LiFeP04	
SELF-CONTAINED LUMINAIRES WITH WIRELESS PROFESSIONAL MODULE (SWITCHABLE)							
LED, 1h, 230V AC	AXCP401WL	AXCP401WL-AZ	AXCP401WL-E	1 h	5,6 W	6,4V/1,2Ah LiFeP04	
LED, 3h, 230V AC	AXCP403WL	AXCP403WL-AZ	AXCP403WL-E	3 h	5,6 W	6,4V/1,2Ah LiFeP04	
LED, 8h, 230V AC	AXCP408WL	AXCP408WL-AZ	AXCP408WL-E	8 h	5,6 W	6,4V/1,2Ah LiFeP04	
LUMINAIRES FOR CORE COMPACT LOW-POWER SYSTEMS 24V AC/DC INCL. MONITORING MODULE							
LED, 24V, AC/DC	AXCP509CC	AXCP509CC-AZ	AXCP509CC-E	CPS	3,7 W		
LUMINAIRES FOR CENTRAL BATTERY SYSTEMS AC/DC							
LED, 230V AC/DC	AXCP009	AXCP009-AZ	AXCP009-E	CPS	3,3 W		
LUMINAIRES FOR CENTRAL BATTERY SYSTEMS AC/DC INCL. MONITORING MODULE							
LED, 230V AC/DC	AXCP009ML	AXCP009ML-AZ	AXCP009ML-E	CPS	4,5 W		

INDUSTRIAL LUMINAIRES

GENERAL LIGHTING WITH EMERGENCY LIGHT

WIRELESS MONITORING

ACCESSORIES

MODULES



CEILING MOUNTING WITH PENDULUM



AM – VIEWING DISTANCE 22M

SELF-CONTAINED LUMINAIRES WITH SELFCONTROL MODULE							
LED, 1h, 230V AC	AMDP401SC	AMDP401SC-AZ	AMDP401SC-E	1 h	4,3 W	6,4V/1,2Ah LiFeP04	
LED, 3h, 230V AC	AMDP403SC	AMDP403SC-AZ	AMDP403SC-E	3 h	4,3 W	6,4V/1,2Ah LiFeP04	
LED, 8h, 230V AC	AMDP408SC	AMDP408SC-AZ	AMDP408SC-E	8 h	4,3 W	6,4V/1,2Ah LiFeP04	
SELF-CONTAINED LUMINAIRES WITH WIRELESS PROFESSIONAL MODULE (SWITCHABLE)							
LED, 1h, 230V AC	AMDP401WL	AMDP401WL-AZ	AMDP401WL-E	1 h	4,7 W	6,4V/1,2Ah LiFeP04	
LED, 3h, 230V AC	AMDP403WL	AMDP403WL-AZ	AMDP403WL-E	3 h	4,7 W	6,4V/1,2Ah LiFeP04	
LED, 8h, 230V AC	AMDP408WL	AMDP408WL-AZ	AMDP408WL-E	8 h	4,7 W	6,4V/1,2Ah LiFeP04	
LUMINAIRES FOR CORE COMPACT LOW-POWER SYSTEMS 24V AC/DC INCL. MONITORING MODULE							
LED, 24V, AC/DC	AMDP509CC	AMDP509CC-AZ	AMDP509CC-E	CPS	2,6 W		
LUMINAIRES FOR CENTRAL BATTERY SYSTEMS AC/DC							
LED, 230V AC/DC	AMDP009	AMDP009-AZ	AMDP009-E	CPS	2,4 W		
LUMINAIRES FOR CENTRAL BATTERY SYSTEMS AC/DC INCL. MONITORING MODULE							
LED, 230V AC/DC	AMDP009ML	AMDP009ML-AZ	AMDP009ML-E	CPS	3,5 W		



AX DP

CEILING MOUNTING WITH PENDULUM



AX – VIEWING DISTANCE 30M

SELF-CONTAINED LUMINAIRES WITH SELFCONTROL MODULE							
LED, 1h, 230V AC	AXDP401SC	AXDP401SC-AZ	AXDP401SC-E	1 h	4,2 W	6,4V/1,2Ah LiFeP04	
LED, 3h, 230V AC	AXDP403SC	AXDP403SC-AZ	AXDP403SC-E	3 h	4,2 W	6,4V/1,2Ah LiFeP04	
LED, 8h, 230V AC	AXDP408SC	AXDP408SC-AZ	AXDP408SC-E	8 h	4,2 W	6,4V/1,2Ah LiFeP04	
SELF-CONTAINED LUMINAIRES WITH WIRELESS PROFESSIONAL MODULE (SWITCHABLE)							
LED, 1h, 230V AC	AXDP401WL	AXDP401WL-AZ	AXDP401WL-E	1 h	5,6 W	6,4V/1,2Ah LiFeP04	
LED, 3h, 230V AC	AXDP403WL	AXDP403WL-AZ	AXDP403WL-E	3 h	5,6 W	6,4V/1,2Ah LiFeP04	
LED, 8h, 230V AC	AXDP408WL	AXDP408WL-AZ	AXDP408WL-E	8 h	5,6 W	6,4V/1,2Ah LiFeP04	
LUMINAIRES FOR CORE COMPACT LOW-POWER SYSTEMS 24V AC/DC INCL. MONITORING MODULE							
LED, 24V, AC/DC	AXDP509CC	AXDP509CC-AZ	AXDP509CC-E	CPS	3,7 W		
LUMINAIRES FOR CENTRAL BATTERY SYSTEMS AC/DC							
LED, 230V AC/DC	AXDP009	AXDP009-AZ	AXDP009-E	CPS	3,3 W		
LUMINAIRES FOR CENTRAL BATTERY SYSTEMS AC/DC INCL. MONITORING MODULE							
LED, 230V AC/DC	AXDP009ML	AXDP009ML-AZ	AXDP009ML-E	CPS	4,5 W		



RECESSED WALL MOUNTING WITH WALL BRACKET



AM – VIEWING DISTANCE 22M

SELF-CONTAINED LUMINAIRES WITH SELFCONTROL MODULE							
LED, 1h, 230V AC	AMRA401SC	AMRA401SC-AZ	AMRA401SC-E	1 h	4,3 W	6,4V/1,2Ah LiFeP04	
LED, 3h, 230V AC	AMRA403SC	AMRA403SC-AZ	AMRA403SC-E	3 h	4,3 W	6,4V/1,2Ah LiFeP04	
LED, 8h, 230V AC	AMRA408SC	AMRA408SC-AZ	AMRA408SC-E	8 h	4,3 W	6,4V/1,2Ah LiFeP04	
SELF-CONTAINED LUMINAIRES WITH WIRELESS PROFESSIONAL MODULE (SWITCHABLE)							
LED, 3h, 230V AC	AMRA403WL	AMRA403WL-AZ	AMRA403WL-E	3 h	4,7 W	6,4V/1,2Ah LiFeP04	
LED, 8h, 230V AC	AMRA401WL	AMRA401WL-AZ	AMRA401WL-E	1 h	4,7 W	6,4V/1,2Ah LiFeP04	
LED, 8h, 230V AC	AMRA408WL	AMRA408WL-AZ	AMRA408WL-E	8 h	4,7 W	6,4V/1,2Ah LiFeP04	
LUMINAIRES FOR CORE COMPACT LOW-POWER SYSTEMS 24V AC/DC INCL. MONITORING MODULE							
LED, 24V, AC/DC	AMRA509CC	AMRA509CC-AZ	AMRA509CC-E	CPS	2,6 W		
LUMINAIRES FOR CENTRAL BATTERY SYSTEMS AC/DC							
LED, 230V AC/DC	AMRA009	AMRA009-AZ	AMRA009-E	CPS	2,4 W		
LUMINAIRES FOR CENTRAL BATTERY SYSTEMS AC/DC INCL. MONITORING MODULE							
LED, 230V AC/DC	AMRA009ML	AMRA009ML-AZ	AMRA009ML-E	CPS	3,5 W		



RECESSED WALL MOUNTING WITH WALL BRACKET



AX – VIEWING DISTANCE 30M

SELF-CONTAINED LUMINAIRES WITH SELFCONTROL MODULE							
LED, 1h, 230V AC	AXRA401SC	AXRA401SC-AZ	AXRA401SC-E	1 h	4,2 W	6,4V/1,2Ah LiFeP04	
LED, 3h, 230V AC	AXRA403SC	AXRA403SC-AZ	AXRA403SC-E	3 h	4,2 W	6,4V/1,2Ah LiFeP04	
LED, 8h, 230V AC	AXRA408SC	AXRA408SC-AZ	AXRA408SC-E	8 h	4,2 W	6,4V/1,2Ah LiFeP04	
SELF-CONTAINED LUMINAIRES WITH WIRELESS PROFESSIONAL MODULE (SWITCHABLE)							
LED, 1h, 230V AC	AXRA401WL	AXRA401WL-AZ	AXRA401WL-E	1 h	5,6 W	6,4V/1,2Ah LiFeP04	
LED, 3h, 230V AC	AXRA403WL	AXRA403WL-AZ	AXRA403WL-E	3 h	5,6 W	6,4V/1,2Ah LiFeP04	
LED, 8h, 230V AC	AXRA408WL	AXRA408WL-AZ	AXRA408WL-E	8 h	5,6 W	6,4V/1,2Ah LiFeP04	
LUMINAIRES FOR CORE COMPACT LOW-POWER SYSTEMS 24V AC/DC INCL. MONITORING MODULE							
LED, 24V, AC/DC	AXRA509CC	AXRA509CC-AZ	AXRA509CC-E	CPS	3,7 W		
LUMINAIRES FOR CENTRAL BATTERY SYSTEMS AC/DC							
LED, 230V AC/DC	AXRA009	AXRA009-AZ	AXRA009-E	CPS	3,3 W		
LUMINAIRES FOR CENTRAL BATTERY SYSTEMS AC/DC INCL. MONITORING MODULE							
LED, 230V AC/DC	AXRA009ML	AXRA009ML-AZ	AXRA009ML-E	CPS	4,5 W		



WALL MOUNTING WITH WALL BRACKET



AM – VIEWING DISTANCE 22M

SELF-CONTAINED LUMINAIRES WITH SELFCONTROL MODULE							
LED, 1h, 230V AC	AMWA401SC	AMWA401SC-AZ	AMWA401SC-E	1 h	4,3 W	6,4V/1,2Ah LiFeP04	
LED, 3h, 230V AC	AMWA403SC	AMWA403SC-AZ	AMWA403SC-E	3 h	4,3 W	6,4V/1,2Ah LiFeP04	
LED, 8h, 230V AC	AMWA408SC	AMWA408SC-AZ	AMWA408SC-E	8 h	4,3 W	6,4V/1,2Ah LiFeP04	
SELF-CONTAINED LUMINAIRES WITH WIRELESS PROFESSIONAL MODULE (SWITCHABLE)							
LED, 1h, 230V AC	AMWA401WL	AMWA401WL-AZ	AMWA401WL-E	1 h	4,7 W	6,4V/1,2Ah LiFeP04	
LED, 3h, 230V AC	AMWA403WL	AMWA403WL-AZ	AMWA403WL-E	3 h	4,7 W	6,4V/1,2Ah LiFeP04	
LED, 8h, 230V AC	AMWA408WL	AMWA408WL-AZ	AMWA408WL-E	8 h	4,7 W	6,4V/1,2Ah LiFeP04	
LUMINAIRES FOR CORE COMPACT LOW-POWER SYSTEMS 24V AC/DC INCL. MONITORING MODULE							
LED, 24V, AC/DC	AMWA509CC	AMWA509CC-AZ	AMWA509CC-E	CPS	2,6 W		
LUMINAIRES FOR CENTRAL BATTERY SYSTEMS AC/DC							
LED, 230V AC/DC	AMWA009	AMWA009-AZ	AMWA009-E	CPS	2,4 W		
LUMINAIRES FOR CENTRAL BATTERY SYSTEMS AC/DC INCL. MONITORING MODULE							
LED, 230V AC/DC	AMWA009ML	AMWA009ML-AZ	AMWA009ML-E	CPS	3,5 W		



WALL MOUNTING WITH WALL BRACKET



AX – VIEWING DISTANCE 30M

SELF-CONTAINED LUMINAIRES WITH SELFCONTROL MODULE							
LED, 1h, 230V AC	AXWA401SC	AXWA401SC-AZ	AXWA401SC-E	1 h	4,2 W	6,4V/1,2Ah LiFeP04	
LED, 3h, 230V AC	AXWA403SC	AXWA403SC-AZ	AXWA403SC-E	3 h	4,2 W	6,4V/1,2Ah LiFeP04	
LED, 8h, 230V AC	AXWA408SC	AXWA408SC-AZ	AXWA408SC-E	8 h	4,2 W	6,4V/1,2Ah LiFeP04	
SELF-CONTAINED LUMINAIRES WITH WIRELESS PROFESSIONAL MODULE (SWITCHABLE)							
LED, 1h, 230V AC	AXWA401WL	AXWA401WL-AZ	AXWA401WL-E	1 h	5,6 W	6,4V/1,2Ah LiFeP04	
LED, 3h, 230V AC	AXWA403WL	AXWA403WL-AZ	AXWA403WL-E	3 h	5,6 W	6,4V/1,2Ah LiFeP04	
LED, 8h, 230V AC	AXWA408WL	AXWA408WL-AZ	AXWA408WL-E	8 h	5,6 W	6,4V/1,2Ah LiFeP04	
LUMINAIRES FOR CORE COMPACT LOW-POWER SYSTEMS 24V AC/DC INCL. MONITORING MODULE							
LED, 24V, AC/DC	AXWA509CC	AXWA509CC-AZ	AXWA509CC-E	CPS	3,7 W		
LUMINAIRES FOR CENTRAL BATTERY SYSTEMS AC/DC							
LED, 230V AC/DC	AXWA009	AXWA009-AZ	AXWA009-E	CPS	3,3 W		
LUMINAIRES FOR CENTRAL BATTERY SYSTEMS AC/DC INCL. MONITORING MODULE							
LED, 230V AC/DC	AXWA009ML	AXWA009ML-AZ	AXWA009ML-E	CPS	4,5 W		



RECESSED CEILING MOUNTING - CIRCULAR CUT-OUT



AM – VIEWING DISTANCE 22M

SELF-CONTAINED LUMINAIRES WITH SELFCONTROL MODULE							
LED, 1h, 230V AC	AME401SC	AME401SC-AZ	AME401SC-E	1 h	4,3 W	6,4V/1,2Ah LiFeP04	
LED, 3h, 230V AC	AME403SC	AME403SC-AZ	AME403SC-E	3 h	4,3 W	6,4V/1,2Ah LiFeP04	
LED, 8h, 230V AC	AME408SC	AME408SC-AZ	AME408SC-E	8 h	4,3 W	6,4V/1,2Ah LiFeP04	
SELF-CONTAINED LUMINAIRES WITH WIRELESS PROFESSIONAL MODULE (SWITCHABLE)							
LED, 1h, 230V AC	AME401WL	AME401WL-AZ	AME401WL-E	1 h	4,7 W	6,4V/1,2Ah LiFeP04	
LED, 3h, 230V AC	AME403WL	AME403WL-AZ	AME403WL-E	3 h	4,7 W	6,4V/1,2Ah LiFeP04	
LED, 8h, 230V AC	AME408WL	AME408WL-AZ	AME408WL-E	8 h	4,7 W	6,4V/1,2Ah LiFeP04	
LUMINAIRES FOR CORE COMPACT LOW-POWER SYSTEMS 24V AC/DC INCL. MONITORING MODULE							
LED, 24V, AC/DC	AME509CC	AME509CC-AZ	AME509CC-E	CPS	2,5 W		
LUMINAIRES FOR CENTRAL BATTERY SYSTEMS AC/DC							
LED, 230V AC/DC	AME009	AME009-AZ	AME009-E	CPS	2,4 W		
LUMINAIRES FOR CENTRAL BATTERY SYSTEMS AC/DC INCL. MONITORING MODULE							
LED, 230V AC/DC	AME009ML	AME009ML-AZ	AME009ML-E	CPS	3,2 W		



RECESSED CEILING MOUNTING - CIRCULAR CUT-OUT



AX – VIEWING DISTANCE 30M

SELF-CONTAINED LUMINAIRES WITH SELFCONTROL MODULE							
LED, 1h, 230V AC	AXE401SC	AXE401SC-AZ	AXE401SC-E	1 h	4,2 W	6,4V/1,2Ah LiFeP04	
LED, 3h, 230V AC	AXE403SC	AXE403SC-AZ	AXE403SC-E	3 h	4,2 W	6,4V/1,2Ah LiFeP04	
LED, 8h, 230V AC	AXE408SC	AXE408SC-AZ	AXE408SC-E	8 h	4,2 W	6,4V/1,2Ah LiFeP04	
SELF-CONTAINED LUMINAIRES WITH WIRELESS PROFESSIONAL MODULE (SWITCHABLE)							
LED, 1h, 230V AC	AXE401WL	AXE401WL-AZ	AXE401WL-E	1 h	5,6 W	6,4V/1,2Ah LiFeP04	
LED, 3h, 230V AC	AXE403WL	AXE403WL-AZ	AXE403WL-E	3 h	5,6 W	6,4V/1,2Ah LiFeP04	
LED, 8h, 230V AC	AXE408WL	AXE408WL-AZ	AXE408WL-E	8 h	5,6 W	6,4V/1,2Ah LiFeP04	
LUMINAIRES FOR CORE COMPACT LOW-POWER SYSTEMS 24V AC/DC INCL. MONITORING MODULE							
LED, 24V, AC/DC	AXE509CC	AXE509CC-AZ	AXE509CC-E	CPS	3,6 W		
LUMINAIRES FOR CENTRAL BATTERY SYSTEMS AC/DC							
LED, 230V AC/DC	AXE009	AXE009-AZ	AXE009-E	CPS	3,3 W		
LUMINAIRES FOR CENTRAL BATTERY SYSTEMS AC/DC INCL. MONITORING MODULE							
LED, 230V AC/DC	AXE009ML	AXE009ML-AZ	AXE009ML-E	CPS	4,5 W		



RECESSED CEILING MOUNTING WITH CORD SUSPENSION - CIRCULAR CUT-OUT



AM – VIEWING DISTANCE 22M

SELF-CONTAINED LUMINAIRES WITH SELFCONTROL MODULE								
LED, 1h, 230V AC	AMEC401SC	AMEC401SC-AZ	AMEC401SC-E	1 h	4,3 W	6,4V/1,2Ah LiFeP04		
LED, 3h, 230V AC	AMEC403SC	AMEC403SC-AZ	AMEC403SC-E	3 h	4,3 W	6,4V/1,2Ah LiFeP04		
LED, 8h, 230V AC	AMEC408SC	AMEC408SC-AZ	AMEC408SC-E	8 h	4,3 W	6,4V/1,2Ah LiFeP04		
SELF-CONTAINED LUMINAIRES WITH WIRELESS PROFESSIONAL MODULE (SWITCHABLE)								
LED, 1h, 230V AC	AMEC401WL	AMEC401WL-AZ	AMEC401WL-E	1 h	4,7 W	6,4V/1,2Ah LiFeP04		
LED, 3h, 230V AC	AMEC403WL	AMEC403WL-AZ	AMEC403WL-E	3 h	4,7 W	6,4V/1,2Ah LiFeP04		
LED, 8h, 230V AC	AMEC408WL	AMEC408WL-AZ	AMEC408WL-E	8 h	4,7 W	6,4V/1,2Ah LiFeP04		
LUMINAIRES FOR CORE COMPACT LOW-POWER SYSTEMS 24V AC/DC INCL. MONITORING MODULE								
LED, 24V, AC/DC	AMEC509CC	AMEC509CC-AZ	AMEC509CC-E	CPS	2,5 W			
LUMINAIRES FOR CENTRAL BATTERY SYSTEMS AC/DC								
LED, 230V AC/DC	AMEC009	AMEC009-AZ	AMEC009-E	CPS	2,4 W			
LUMINAIRES FOR CENTRAL BATTERY SYSTEMS AC/DC INCL. MONITORING MODULE								
LED, 230V AC/DC	AMEC009ML	AMEC009ML-AZ	AMEC009ML-E	CPS	3,5 W			



RECESSED CEILING MOUNTING WITH CORD SUSPENSION - CIRCULAR CUT-OUT



AX – VIEWING DISTANCE 30M

SELF-CONTAINED LUMINAIRES WITH SELFCONTROL MODULE									
LED, 1h, 230V AC	AXEC401SC	AXEC401SC-AZ	AXEC401SC-E	1 h	4,2 W	6,4V/1,2Ah LiFeP04			
LED, 3h, 230V AC	AXEC403SC	AXEC403SC-AZ	AXEC403SC-E	3 h	4,2 W	6,4V/1,2Ah LiFeP04			
LED, 8h, 230V AC	AXEC408SC	AXEC408SC-AZ	AXEC408SC-E	8 h	4,2 W	6,4V/1,2Ah LiFeP04			
SELF-CONTAINED LUMINAIRES WITH WIRELESS PROFESSIONAL MODULE (SWITCHABLE)									
LED, 1h, 230V AC	AXEC401WL	AXEC401WL-AZ	AXEC401WL-E	1 h	5,6 W	6,4V/1,2Ah LiFeP04			
LED, 3h, 230V AC	AXEC403WL	AXEC403WL-AZ	AXEC403WL-E	3 h	5,6 W	6,4V/1,2Ah LiFeP04			
LED, 8h, 230V AC	AXEC408WL	AXEC408WL-AZ	AXEC408WL-E	8 h	5,6 W	6,4V/1,2Ah LiFeP04			
LUMINAIRES FOR CORE COMPACT LOW-POWER SYSTEMS 24V AC/DC INCL. MONITORING MODULE									
LED, 24V, AC/DC	AXEC509CC	AXEC509CC-AZ	AXEC509CC-E	CPS	3,6 W				
LUMINAIRES FOR CENTRAL BATTERY SYSTEMS AC/DC									
LED, 230V AC/DC	AXEC009	AXEC009-AZ	AXEC009-E	CPS	3,3 W				
LUMINAIRES FOR CENTRAL BATTERY SYSTEMS AC/DC INCL. MONITORING MODULE									
LED, 230V AC/DC	AXEC009ML	AXEC009ML-AZ	AXEC009ML-E	CPS	4,5 W				



RECESSED CEILING MOUNTING WITH PENDULUM - CIRCULAR CUT-OUT



AM – VIEWING DISTANCE 22M

SELF-CONTAINED LUMINAIRES WITH SELFCONTROL MODULE							
LED, 1h, 230V AC	AMEP401SC	AMEP401SC-AZ	AMEP401SC-E	1 h	4,3 W	6,4V/1,2Ah LiFeP04	
LED, 3h, 230V AC	AMEP403SC	AMEP403SC-AZ	AMEP403SC-E	3 h	4,3 W	6,4V/1,2Ah LiFeP04	
LED, 8h, 230V AC	AMEP408SC	AMEP408SC-AZ	AMEP408SC-E	8 h	4,3 W	6,4V/1,2Ah LiFeP04	
SELF-CONTAINED LUMINAIRES WITH WIRELESS PROFESSIONAL MODULE (SWITCHABLE)							
LED, 1h, 230V AC	AMEP401WL	AMEP401WL-AZ	AMEP401WL-E	1 h	4,7 W	6,4V/1,2Ah LiFeP04	
LED, 3h, 230V AC	AMEP403WL	AMEP403WL-AZ	AMEP403WL-E	3 h	4,7 W	6,4V/1,2Ah LiFeP04	
LED, 8h, 230V AC	AMEP408WL	AMEP408WL-AZ	AMEP408WL-E	8 h	4,7 W	6,4V/1,2Ah LiFeP04	
LUMINAIRES FOR CORE COMPACT LOW-POWER SYSTEMS 24V AC/DC INCL. MONITORING MODULE							
LED, 24V, AC/DC	AMEP509CC	AMEP509CC-AZ	AMEP509CC-E	CPS	2,5 W		
LUMINAIRES FOR CENTRAL BATTERY SYSTEMS AC/DC							
LED, 230V AC/DC	AMEP009	AMEP009-AZ	AMEP009-E	CPS	2,4 W		
LUMINAIRES FOR CENTRAL BATTERY SYSTEMS AC/DC INCL. MONITORING MODULE							
LED, 230V AC/DC	AMEP009ML	AMEP009ML-AZ	AMEP009ML-E	CPS	3,5 W		



RECESSED CEILING MOUNTING WITH PENDULUM - CIRCULAR CUT-OUT



AX – VIEWING DISTANCE 30M

SELF-CONTAINED LUMINAIRES WITH SELFCONTROL MODULE							
LED, 1h, 230V AC	AXEP401SC	AXEP401SC-AZ	AXEP401SC-E	1 h	4,2 W	6,4V/1,2Ah LiFeP04	
LED, 3h, 230V AC	AXEP403SC	AXEP403SC-AZ	AXEP403SC-E	3 h	4,2 W	6,4V/1,2Ah LiFeP04	
LED, 8h, 230V AC	AXEP408SC	AXEP408SC-AZ	AXEP408SC-E	8 h	4,2 W	6,4V/1,2Ah LiFeP04	
SELF-CONTAINED LUMINAIRES WITH WIRELESS PROFESSIONAL MODULE (SWITCHABLE)							
LED, 1h, 230V AC	AXEP401WL	AXEP401WL-AZ	AXEP401WL-E	1 h	5,6 W	6,4V/1,2Ah LiFeP04	
LED, 3h, 230V AC	AXEP403WL	AXEP403WL-AZ	AXEP403WL-E	3 h	5,6 W	6,4V/1,2Ah LiFeP04	
LED, 8h, 230V AC	AXEP408WL	AXEP408WL-AZ	AXEP408WL-E	8 h	5,6 W	6,4V/1,2Ah LiFeP04	
LUMINAIRES FOR CORE COMPACT LOW-POWER SYSTEMS 24V AC/DC INCL. MONITORING MODULE							
LED, 24V, AC/DC	AXEP509CC	AXEP509CC-AZ	AXEP509CC-E	CPS	3,6 W		
LUMINAIRES FOR CENTRAL BATTERY SYSTEMS AC/DC							
LED, 230V AC/DC	AXEP009	AXEP009-AZ	AXEP009-E	CPS	3,3 W		
LUMINAIRES FOR CENTRAL BATTERY SYSTEMS AC/DC INCL. MONITORING MODULE							
LED, 230V AC/DC	AXEP009ML	AXEP009ML-AZ	AXEP009ML-E	CPS	4,5 W		

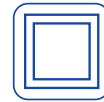

CEILING MOUNTED EXIT SIGN WITH SAFETY LIGHT



AM – VIEWING DISTANCE 22M

LUMINAIRES FOR CENTRAL BATTERY SYSTEMS AC/DC INKL. ÜBERWACHUNGSBAUSTEIN						
LED, 230V AC/DC	AMDT009ML	AMDT009ML-AZ	AMDT009ML-E	CPS	4,2 W	

AX – VIEWING DISTANCE 30M

LUMINAIRES FOR CENTRAL BATTERY SYSTEMS AC/DC INKL. ÜBERWACHUNGSBAUSTEIN						
LED, 230V AC/DC	AXDT009ML	AXDT009ML-AZ	AXDT009ML-E	CPS	4,9 W	

Distance table AMDT / AXDT for plane emergency routes (additional distance tables on our website)

Mounting height (m)					
2.50	3.45	10.49	6.98	3.81	1.60
3.00	0.00	7.44	3.04	4.16	1.69
3.50	0.00	6.72	2.43	3.94	0.76
4.00	0.00	0.95	0.95	0.95	0.43



GERMAN DESIGN AWARD WINNER 2018



AM / AX CT

GENERAL INFORMATIONS

RECESSED CEILING MOUNTED EXIT SIGN WITH SAFETY LIGHT



DESIGN LUMINAIRES

DYNAMIC LUMINAIRES

UNIVERSAL LUMINAIRES

AM – VIEWING DISTANCE 22M

LUMINAIRES FOR CENTRAL BATTERY SYSTEMS AC/DC INKL. ÜBERWACHUNGSBAUSTEIN						
LED, 230V AC/DC	AMCT009ML	AMCT009ML-AZ	AMCT009ML-E	CPS	4,2 W	

INDUSTRIAL LUMINAIRES

GENERAL LIGHTING WITH EMERGENCY LIGHT

AX – VIEWING DISTANCE 30M

LUMINAIRES FOR CENTRAL BATTERY SYSTEMS AC/DC INKL. ÜBERWACHUNGSBAUSTEIN						
LED, 230V AC/DC	AXCT009ML	AXCT009ML-AZ	AXCT009ML-E	CPS	4,9 W	

WIRELESS MONITORING

Distance table AMCT / AXCT for plane emergency routes (additional distance tables on our website)

Mounting height (m)					
2.50	3.45	10.49	6.98	3.81	1.60
3.00	0.00	7.44	3.04	4.16	1.69
3.50	0.00	6.72	2.43	3.94	0.76
4.00	0.00	0.95	0.95	0.95	0.43

ACCESSORIES

MODULES

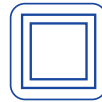

WALL MOUNTING EXIT SIGN WITH ADDITIONAL SAFETY LIGHT

2in1
Safety light and exit sign in one



AM – VIEWING DISTANCE 22M

LUMINAIRES FOR CENTRAL BATTERY SYSTEMS AC/DC INKL. ÜBERWACHUNGSBAUSTEIN						
LED, 230V AC/DC	AMWT009ML	AMWT009ML-AZ	AMWT009ML-E	CPS	3,5 W	

AX – VIEWING DISTANCE 30M

LUMINAIRES FOR CENTRAL BATTERY SYSTEMS AC/DC INKL. ÜBERWACHUNGSBAUSTEIN						
LED, 230V AC/DC	AXWT009ML	AXWT009ML-AZ	AXWT009ML-E	CPS	4,5 W	

Distance table AMWT / AXWT for plane emergency routes (additional distance tables on our website)

Mounting height (m)					
2.50	0.89	3.34	3.37	5.28	2.19
3.00	1.05	3.72	3.74	5.73	2.37
3.50	1.19	4.03	4.04	6.15	2.50
4.00	1.33	4.25	4.26	6.50	2.61



DIMENSIONS

WALL MOUNTING

Dimensions AM Wall mounting

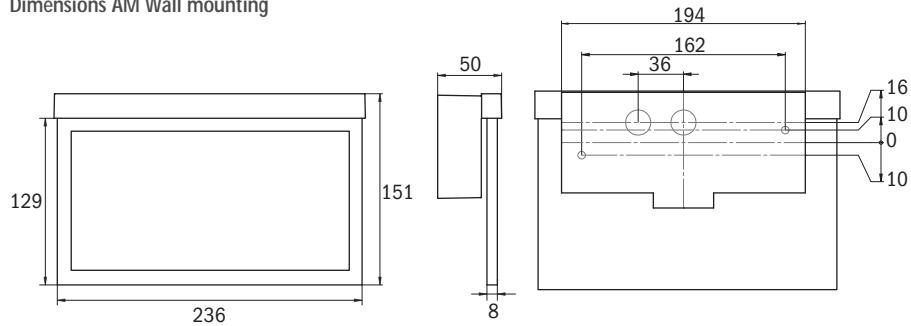

Dimensions AX Wall mounting

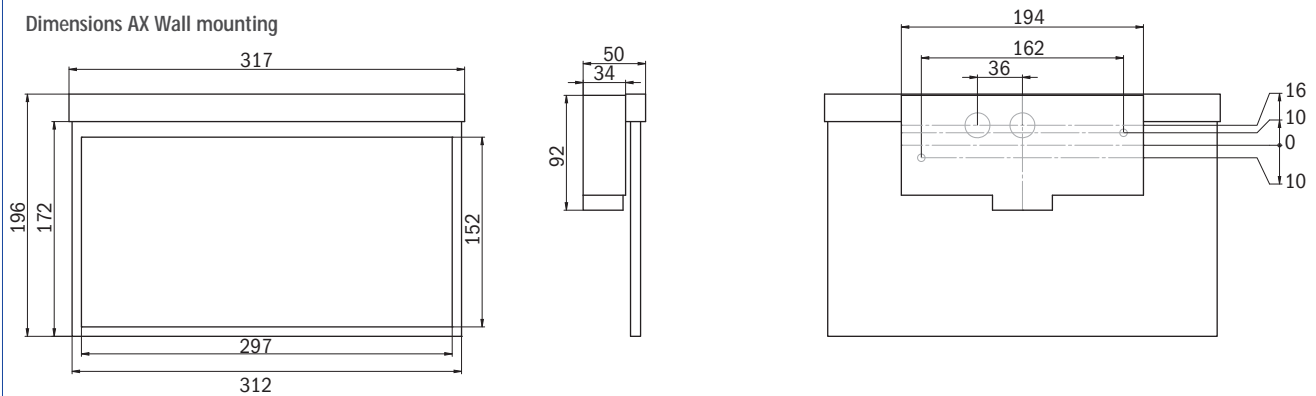

CEILING MOUNTING

Dimensions AM CEILING MOUNTING

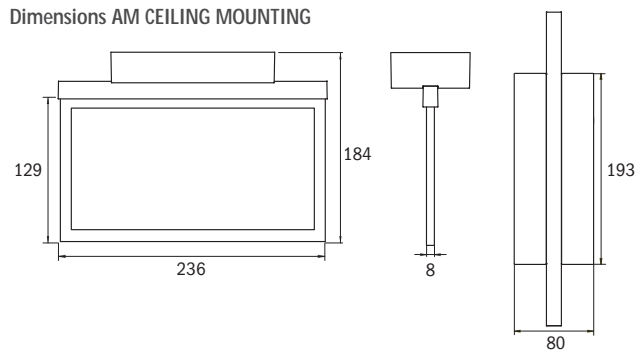

Dimensions AX CEILING MOUNTING

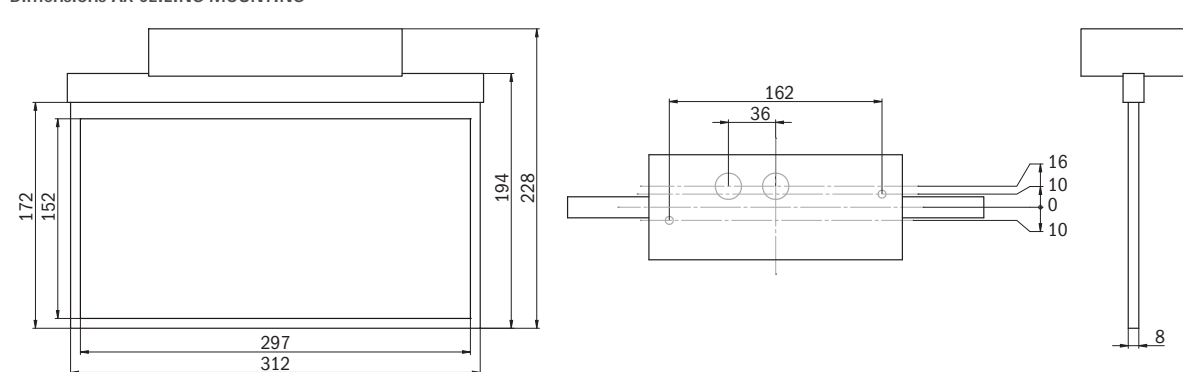

RECESSED MOUNTING

Cut-out for recessed mounting AMC/AXC

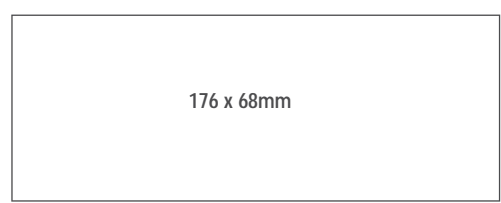
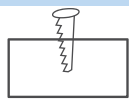

Cut-out for recessed mounting AME/AXE

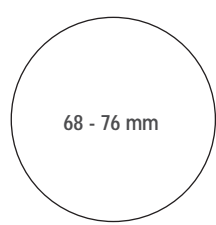

RECESSED WALL MOUNTING

Dimensions AMR Recessed wall mounting

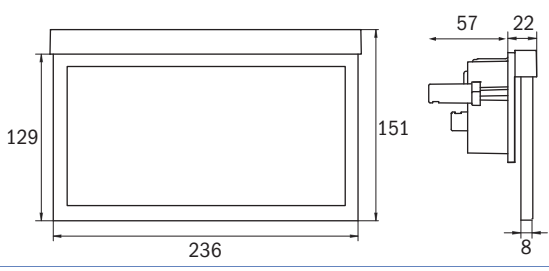

Dimensions AXR Recessed wall mounting

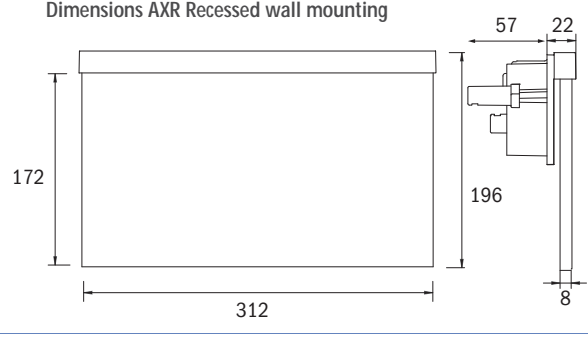

RECESSED CEILING MOUNTING

Dimensions AM Recessed ceiling mounting AMC

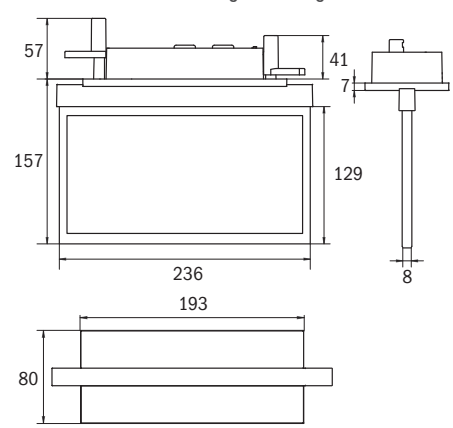

Dimensions AX Recessed ceiling mounting AXC

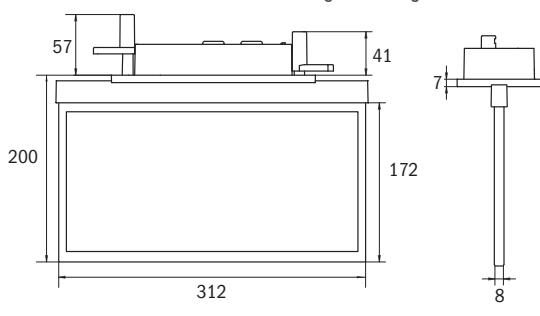

ACCESSORIES



Cord suspension:
Standard length 1500mm
(reducible)



Pendulum:
Standard length 500mm
(reducible)



Pendulum ball joint
AM-X-PKG-WS (white),
AM-X-PKG-AZ (anthracite),
AM-X-PKG-E (stainless steel
look)



Surface mounting adapter
for lateral cable feed
AM-X-APA (white),
AM-X-APA-AZ (anthracite),
AM-X-APA-E (stainless steel
look)

All dimensions in mm

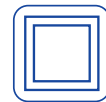

CEILING MOUNTING



AGD – VIEWING DISTANCE 50M

SELF-CONTAINED LUMINAIRES WITH SELFCONTROL MODULE						
LED, 1h, 230V AC	AGD401SC	AGD401SC-AZ	AGD401SC-E	1 h	4,2 W	6,4V/1,2Ah LiFeP04
LED, 3h, 230V AC	AGD403SC	AGD403SC-AZ	AGD403SC-E	3 h	4,2 W	6,4V/1,2Ah LiFeP04
SELF-CONTAINED LUMINAIRES WITH WIRELESS PROFESSIONAL MODULE (SWITCHABLE)						
LED, 1h, 230V AC	AGD401WL	AGD401WL-AZ	AGD401WL-E	1 h	7 W	6,4V/1,2Ah LiFeP04
LED, 3h, 230V AC	AGD403WL	AGD403WL-AZ	AGD403WL-E	3 h	7 W	6,4V/1,2Ah LiFeP04
LED, 8h, 230V AC	AGD408WL	AGD408WL-AZ	AGD408WL-E	8 h	7 W	6,4V/1,2Ah LiFeP04
LUMINAIRES FOR CENTRAL BATTERY SYSTEMS AC/DC						
LED, 230V AC/DC	AGD009	AGD009-AZ	AGD009-E	CPS	5,2 W	
LUMINAIRES FOR CENTRAL BATTERY SYSTEMS AC/DC INCL. MONITORING MODULE						
LED, 230V AC/DC	AGD009ML	AGD009ML-AZ	AGD009ML-E	CPS	6,1 W	



GERMAN
DESIGN
AWARD
WINNER
2018



AGC

GENERAL
INFORMATIONS

RECESSED CEILING MOUNTING

DESIGN LUMINAIRES

DYNAMIC
LUMINAIRES

UNIVERSAL
LUMINAIRES

INDUSTRIAL
LUMINAIRES

GENERAL LIGHTING
WITH EMERGENCY LIGHT

WIRELESS MONITORING

ACCESSORIES

MODULES



AGC – VIEWING DISTANCE 50M

SELF-CONTAINED LUMINAIRES WITH SELFCONTROL MODULE							
LED, 1h, 230V AC	AGC401SC	AGC401SC-AZ	AGC401SC-E	1 h	4,2 W	6,4V/1,2Ah LiFeP04	
LED, 3h, 230V AC	AGC403SC	AGC403SC-AZ	AGC403SC-E	3 h	4,2 W	6,4V/1,2Ah LiFeP04	
SELF-CONTAINED LUMINAIRES WITH WIRELESS PROFESSIONAL MODULE (SWITCHABLE)							
LED, 1h, 230V AC	AGC401WL	AGC401WL-AZ	AGC401WL-E	1 h	7 W	6,4V/1,2Ah LiFeP04	
LED, 3h, 230V AC	AGC403WL	AGC403WL-AZ	AGC403WL-E	3 h	7 W	6,4V/1,2Ah LiFeP04	
LED, 8h, 230V AC	AGC408WL	AGC408WL-AZ	AGC408WL-E	8 h	7 W	6,4V/1,2Ah LiFeP04	
LUMINAIRES FOR CENTRAL BATTERY SYSTEMS AC/DC							
LED, 230V AC/DC	AGC009	AGC009-AZ	AGC009-E	CPS	5,2 W		
LUMINAIRES FOR CENTRAL BATTERY SYSTEMS AC/DC INCL. MONITORING MODULE							
LED, 230V AC/DC	AGC009ML	AGC009ML-AZ	AGC009ML-E	CPS	6,1 W		



CEILING MOUNTING WITH CORD SUSPENSION



AGDC – VIEWING DISTANCE 50M

SELF-CONTAINED LUMINAIRES WITH SELFCONTROL MODULE							
LED, 1h, 230V AC	AGDC401SC	AGDC401SC-AZ	AGDC401SC-E	1 h	4,2 W	6,4V/1,2Ah LiFeP04	
LED, 3h, 230V AC	AGDC403SC	AGDC403SC-AZ	AGDC403SC-E	3 h	4,2 W	6,4V/1,2Ah LiFeP04	
SELF-CONTAINED LUMINAIRES WITH WIRELESS PROFESSIONAL MODULE (SWITCHABLE)							
LED, 1h, 230V AC	AGDC401WL	AGDC401WL-AZ	AGDC401WL-E	1 h	7 W	6,4V/1,2Ah LiFeP04	
LED, 3h, 230V AC	AGDC403WL	AGDC403WL-AZ	AGDC403WL-E	3 h	7 W	6,4V/1,2Ah LiFeP04	
LED, 8h, 230V AC	AGDC408WL	AGDC408WL-AZ	AGDC408WL-E	8 h	7 W	6,4V/1,2Ah LiFeP04	
LUMINAIRES FOR CENTRAL BATTERY SYSTEMS AC/DC							
LED, 230V AC/DC	AGDC009	AGDC009-AZ	AGDC009-E	CPS	5,2 W		
LUMINAIRES FOR CENTRAL BATTERY SYSTEMS AC/DC INCL. MONITORING MODULE							
LED, 230V AC/DC	AGDC009ML	AGDC009ML-AZ	AGDC009ML-E	CPS	6,1 W		



GERMAN
DESIGN
AWARD
WINNER
2018



AGCC

GENERAL
INFORMATIONS

RECESSED CEILING MOUNTING WITH CORD SUSPENSION



DESIGN LUMINAIRES

DYNAMIC LUMINAIRES

UNIVERSAL LUMINAIRES

INDUSTRIAL LUMINAIRES

GENERAL LIGHTING WITH EMERGENCY LIGHT

AGCC – VIEWING DISTANCE 50M

SELF-CONTAINED LUMINAIRES WITH SELFCONTROL MODULE						
LED, 1h, 230V AC	AGCC401SC	AGCC401SC-AZ	AGCC401SC-E	1 h	4,2 W	6,4V/1,2Ah LiFeP04
LED, 3h, 230V AC	AGCC403SC	AGCC403SC-AZ	AGCC403SC-E	3 h	4,2 W	6,4V/1,2Ah LiFeP04
SELF-CONTAINED LUMINAIRES WITH WIRELESS PROFESSIONAL MODULE (SWITCHABLE)						
LED, 1h, 230V AC	AGCC401WL	AGCC401WL-AZ	AGCC401WL-E	1 h	7 W	6,4V/1,2Ah LiFeP04
LED, 3h, 230V AC	AGCC403WL	AGCC403WL-AZ	AGCC403WL-E	3 h	7 W	6,4V/1,2Ah LiFeP04
LED, 8h, 230V AC	AGCC408WL	AGCC408WL-AZ	AGCC408WL-E	8 h	7 W	6,4V/1,2Ah LiFeP04
LUMINAIRES FOR CENTRAL BATTERY SYSTEMS AC/DC						
LED, 230V AC/DC	AGCC009	AGCC009-AZ	AGCC009-E	CPS	5,2 W	
LUMINAIRES FOR CENTRAL BATTERY SYSTEMS AC/DC INCL. MONITORING MODULE						
LED, 230V AC/DC	AGCC009ML	AGCC009ML-AZ	AGCC009ML-E	CPS	6,1 W	

WIRELESS MONITORING

ACCESSORIES

MODULES



WALL MOUNTING



AGW – VIEWING DISTANCE 50M

SELF-CONTAINED LUMINAIRES WITH SELFCONTROL MODULE						
LED, 1h, 230V AC	AGW401SC	AGW401SC-AZ	AGW401SC-E	1 h	4,2 W	6,4V/1,2Ah LiFeP04
LED, 3h, 230V AC	AGW403SC	AGW403SC-AZ	AGW403SC-E	3 h	4,2 W	6,4V/1,2Ah LiFeP04
SELF-CONTAINED LUMINAIRES WITH WIRELESS PROFESSIONAL MODULE (SWITCHABLE)						
LED, 1h, 230V AC	AGW401WL	AGW401WL-AZ	AGW401WL-E	1 h	7 W	6,4V/1,2Ah LiFeP04
LED, 3h, 230V AC	AGW403WL	AGW403WL-AZ	AGW403WL-E	3 h	7 W	6,4V/1,2Ah LiFeP04
LED, 8h, 230V AC	AGW408WL	AGW408WL-AZ	AGW408WL-E	8 h	7 W	6,4V/1,2Ah LiFeP04
LUMINAIRES FOR CENTRAL BATTERY SYSTEMS AC/DC						
LED, 230V AC/DC	AGW009	AGW009-AZ	AGW009-E	CPS	5,2 W	
LUMINAIRES FOR CENTRAL BATTERY SYSTEMS AC/DC INCL. MONITORING MODULE						
LED, 230V AC/DC	AGW009ML	AGW009ML-AZ	AGW009ML-E	CPS	6,1 W	



RECESSED WALL MOUNTING



AGR – VIEWING DISTANCE 50M

SELF-CONTAINED LUMINAIRES WITH SELFCONTROL MODULE						
LED, 1h, 230V AC	AGR401SC	AGR401SC-AZ	AGR401SC-E	1 h	4,2 W	6,4V/1,2Ah LiFeP04
LED, 3h, 230V AC	AGR403SC	AGR403SC-AZ	AGR403SC-E	3 h	4,2 W	6,4V/1,2Ah LiFeP04
SELF-CONTAINED LUMINAIRES WITH WIRELESS PROFESSIONAL MODULE (SWITCHABLE)						
LED, 1h, 230V AC	AGR401WL	AGR401WL-AZ	AGR401WL-E	1 h	7 W	6,4V/1,2Ah LiFeP04
LED, 3h, 230V AC	AGR403WL	AGR403WL-AZ	AGR403WL-E	3 h	7 W	6,4V/1,2Ah LiFeP04
LED, 8h, 230V AC	AGR408WL	AGR408WL-AZ	AGR408WL-E	8 h	7 W	6,4V/1,2Ah LiFeP04
LUMINAIRES FOR CENTRAL BATTERY SYSTEMS AC/DC						
LED, 230V AC/DC	AGR009	AGR009-AZ	AGR009-E	CPS	5,2 W	
LUMINAIRES FOR CENTRAL BATTERY SYSTEMS AC/DC INCL. MONITORING MODULE						
LED, 230V AC/DC	AGR009ML	AGR009ML-AZ	AGR009ML-E	CPS	6,1 W	

DIMENSIONS

WALL MOUNTING

Dimensions AGW Wall mounting

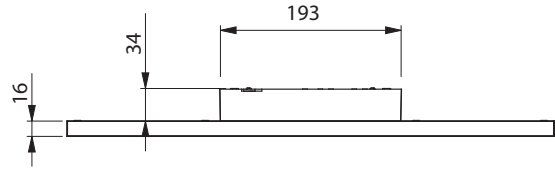
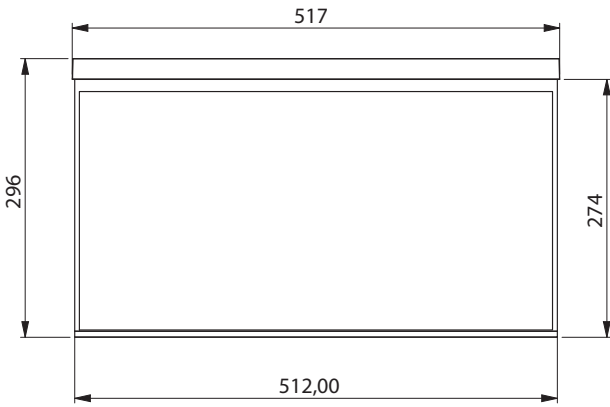

CEILING MOUNTING

Dimensions AGD / AGDC CEILING MOUNTING

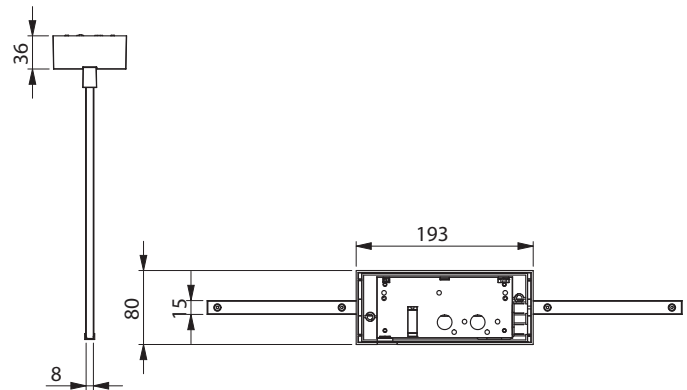
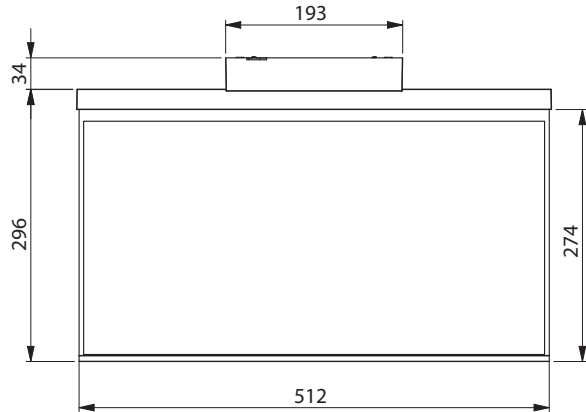

RECESSED MOUNTING

Cut-out for recessed mounting AGC / AGCC

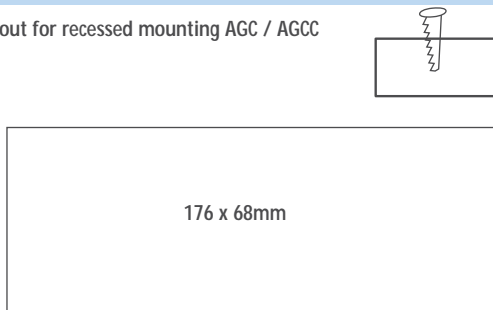

RECESSED WALL MOUNTING

Dimensions AGR Recessed wall mounting

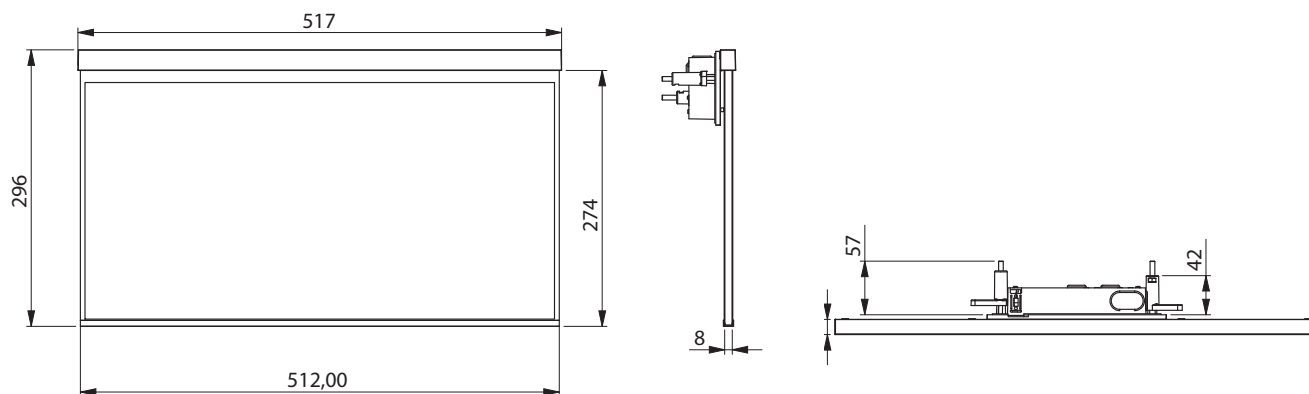

RECESSED CEILING MOUNTING

Dimensions AGC / AGCC Recessed ceiling mounting

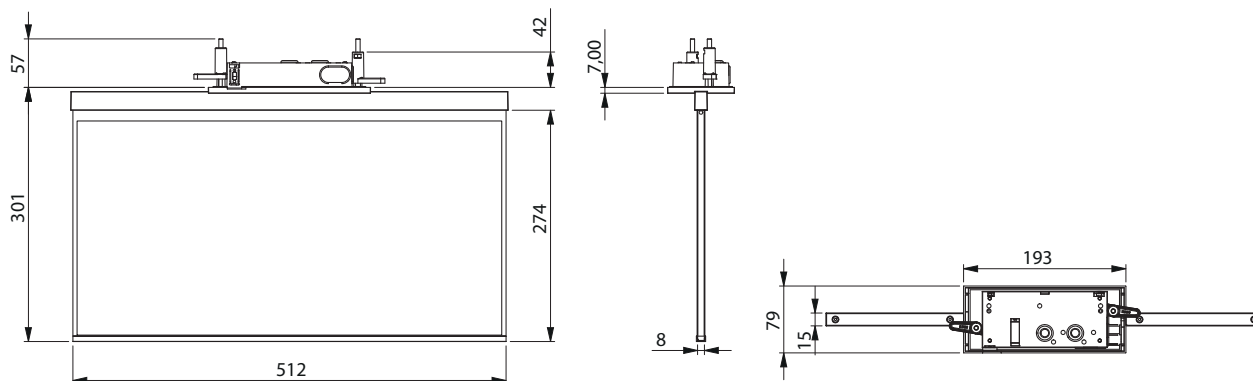



GA-Serie

DESIGN POLYCARBONATE LUMINAIRES

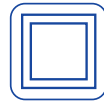

FACTS

- Polycarbonate housing white (RAL 9003)
- 20m (GAM), 30m (GAX) or 40m (GAB) viewing distance
- Complete set of pictographs (ISO 7010)
- IP40
- LED Illuminant
- Wall- or ceiling mounting
- -5° to +40°C



CEILING MOUNTING



GAMD – VIEWING DISTANCE 20M

SELF-CONTAINED LUMINAIRES WITH SELFCONTROL MODULE					
LED, 1h, 230V AC	GAMD401SC		1 h	4,3 W	6,4V/1,2Ah LiFeP04
LED, 3h, 230V AC	GAMD403SC		3 h	4,3 W	6,4V/1,2Ah LiFeP04
LED, 8h, 230V AC	GAMD408SC		8 h	4,3 W	6,4V/1,2Ah LiFeP04
SELF-CONTAINED LUMINAIRES WITH WIRELESS PROFESSIONAL MODULE (SWITCHABLE)					
LED, 1h, 230V AC	GAMD401WL		1 h	4,7 W	6,4V/1,6Ah LiFeP04
LED, 3h, 230V AC	GAMD403WL		3 h	4,7 W	6,4V/1,2Ah LiFeP04
LED, 8h, 230V AC	GAMD408WL		8 h	4,7 W	6,4V/1,2Ah LiFeP04
LUMINAIRES FOR CORE COMPACT LOW-POWER SYSTEMS 24V AC/DC INCL. MONITORING MODULE					
LED, 24V, AC/DC	GAMD509CC		CPS	2,6 W	
LUMINAIRES FOR CENTRAL BATTERY SYSTEMS AC/DC INCL. MONITORING MODULE					
LED, 230V AC/DC	GAMD009ML		CPS	3,5 W	



WALL MOUNTING



GAMW – VIEWING DISTANCE 20M

SELF-CONTAINED LUMINAIRES WITH SELFCONTROL MODULE					
LED, 1h, 230V AC	GAMW401SC		1 h	4,3 W	6,4V/1,2Ah LiFeP04
LED, 3h, 230V AC	GAMW403SC		3 h	4,3 W	6,4V/1,2Ah LiFeP04
LED, 8h, 230V AC	GAMW408SC		8 h	4,3 W	6,4V/1,2Ah LiFeP04
SELF-CONTAINED LUMINAIRES WITH WIRELESS PROFESSIONAL MODULE (SWITCHABLE)					
LED, 1h, 230V AC	GAMW401WL		1 h	4,7 W	6,4V/1,6Ah LiFeP04
LED, 3h, 230V AC	GAMW403WL		3 h	4,7 W	6,4V/1,2Ah LiFeP04
LED, 8h, 230V AC	GAMW408WL		8 h	4,7 W	6,4V/1,2Ah LiFeP04
LUMINAIRES FOR CORE COMPACT LOW-POWER SYSTEMS 24V AC/DC INCL. MONITORING MODULE					
LED, 24V, AC/DC	GAMW509CC		CPS	2,6 W	
LUMINAIRES FOR CENTRAL BATTERY SYSTEMS AC/DC INCL. MONITORING MODULE					
LED, 230V AC/DC	GAMW009ML		CPS	3,5 W	

CEILING MOUNTING



GAXD – VIEWING DISTANCE 30M

SELF-CONTAINED LUMINAIRES WITH SELFCONTROL MODULE					
LED, 1h, 230V AC	GAXD401SC		1 h	4,2 W	6,4V/1,2Ah LiFeP04
LED, 3h, 230V AC	GAXD403SC		3 h	4,2 W	6,4V/1,2Ah LiFeP04
LED, 8h, 230V AC	GAXD408SC		8 h	4,2 W	6,4V/1,2Ah LiFeP04
SELF-CONTAINED LUMINAIRES WITH WIRELESS PROFESSIONAL MODULE (SWITCHABLE)					
LED, 1h, 230V AC	GAXD401WL		1 h	5 W	6,4V/1,2Ah LiFeP04
LED, 3h, 230V AC	GAXD403WL		3 h	5,6 W	6,4V/1,2Ah LiFeP04
LED, 8h, 230V AC	GAXD408WL		8 h	5,6 W	6,4V/1,2Ah LiFeP04
LUMINAIRES FOR CORE COMPACT LOW-POWER SYSTEMS 24V AC/DC INCL. MONITORING MODULE					
LED, 24V, AC/DC	GAXD509CC		CPS	3,7 W	
LUMINAIRES FOR CENTRAL BATTERY SYSTEMS AC/DC INCL. MONITORING MODULE					
LED, 230V AC/DC	GAXD009ML		CPS	4,5 W	



WALL MOUNTING



GAXW – VIEWING DISTANCE 30M

SELF-CONTAINED LUMINAIRES WITH SELFCONTROL MODULE					
LED, 1h, 230V AC	GAXW401SC		1 h	4,2 W	6,4V/1,2Ah LiFeP04
LED, 3h, 230V AC	GAXW403SC		3 h	4,2 W	6,4V/1,2Ah LiFeP04
LED, 8h, 230V AC	GAXW408SC		8 h	4,2 W	6,4V/1,2Ah LiFeP04
SELF-CONTAINED LUMINAIRES WITH WIRELESS PROFESSIONAL MODULE (SWITCHABLE)					
LED, 1h, 230V AC	GAXW401WL		1 h	5,6 W	6,4V/1,2Ah LiFeP04
LED, 3h, 230V AC	GAXW403WL		3 h	5,6 W	6,4V/1,2Ah LiFeP04
LED, 8h, 230V AC	GAXW408WL		8 h	5,6 W	6,4V/1,2Ah LiFeP04
LUMINAIRES FOR CORE COMPACT LOW-POWER SYSTEMS 24V AC/DC INCL. MONITORING MODULE					
LED, 24V, AC/DC	GAXW509CC		CPS	3,7 W	
LUMINAIRES FOR CENTRAL BATTERY SYSTEMS AC/DC INCL. MONITORING MODULE					
LED, 230V AC/DC	GAXW009ML		CPS	4,5 W	

CEILING MOUNTING



GABD – VIEWING DISTANCE 40M

SELF-CONTAINED LUMINAIRES WITH SELFCONTROL MODULE					
LED, 1h, 230V AC	GABD401SC		1 h	4,2 W	6,4V/1,2Ah LiFeP04
LED, 3h, 230V AC	GABD403SC		3 h	4,2 W	6,4V/1,2Ah LiFeP04
LED, 8h, 230V AC	GABD408SC		8 h	4,2 W	6,4V/1,2Ah LiFeP04
SELF-CONTAINED LUMINAIRES WITH WIRELESS PROFESSIONAL MODULE (SWITCHABLE)					
LED, 1h, 230V AC	GABD401WL		1 h	5 W	6,4V/1,2Ah LiFeP04
LED, 3h, 230V AC	GABD403WL		3 h	5 W	6,4V/1,2Ah LiFeP04
LED, 8h, 230V AC	GABD408WL		8 h	5 W	6,4V/1,2Ah LiFeP04
LUMINAIRES FOR CORE COMPACT LOW-POWER SYSTEMS 24V AC/DC INCL. MONITORING MODULE					
LED, 24V, AC/DC	GABD509CC		CPS	3,7 W	
LUMINAIRES FOR CENTRAL BATTERY SYSTEMS AC/DC INCL. MONITORING MODULE					
LED, 230V AC/DC	GABD009ML		CPS	4,6 W	



WALL MOUNTING



GABW – VIEWING DISTANCE 40M

SELF-CONTAINED LUMINAIRES WITH SELFCONTROL MODULE					
LED, 1h, 230V AC	GABW401SC		1 h	4,2 W	6,4V/1,2Ah LiFeP04
LED, 3h, 230V AC	GABW403SC		3 h	4,2 W	6,4V/1,2Ah LiFeP04
LED, 8h, 230V AC	GABW408SC		8 h	4,2 W	6,4V/1,2Ah LiFeP04
SELF-CONTAINED LUMINAIRES WITH WIRELESS PROFESSIONAL MODULE (SWITCHABLE)					
LED, 1h, 230V AC	GABW401WL		1 h	5 W	6,4V/1,2Ah LiFeP04
LED, 3h, 230V AC	GABW403WL		3 h	5 W	6,4V/1,2Ah LiFeP04
LED, 8h, 230V AC	GABW408WL		8 h	5 W	6,4V/1,2Ah LiFeP04
LUMINAIRES FOR CORE COMPACT LOW-POWER SYSTEMS 24V AC/DC INCL. MONITORING MODULE					
LED, 24V, AC/DC	GABW509CC		CPS	3,7 W	
LUMINAIRES FOR CENTRAL BATTERY SYSTEMS AC/DC INCL. MONITORING MODULE					
LED, 230V AC/DC	GABW009ML		CPS	4,6 W	

DIMENSIONS

CEILING MOUNTING

Dimensions GAMD ceiling mounting

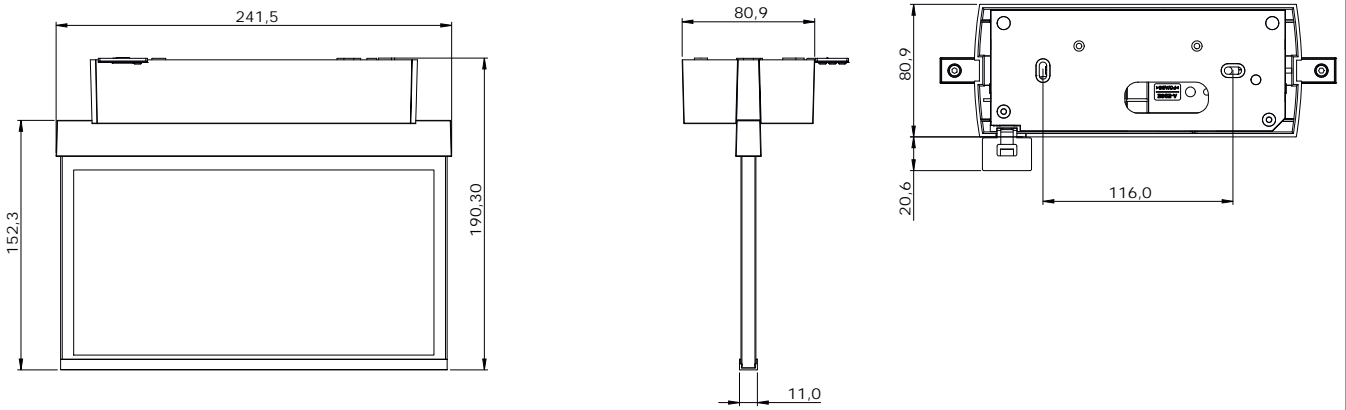

CEILING MOUNTING

Dimensions GAXD ceiling mounting

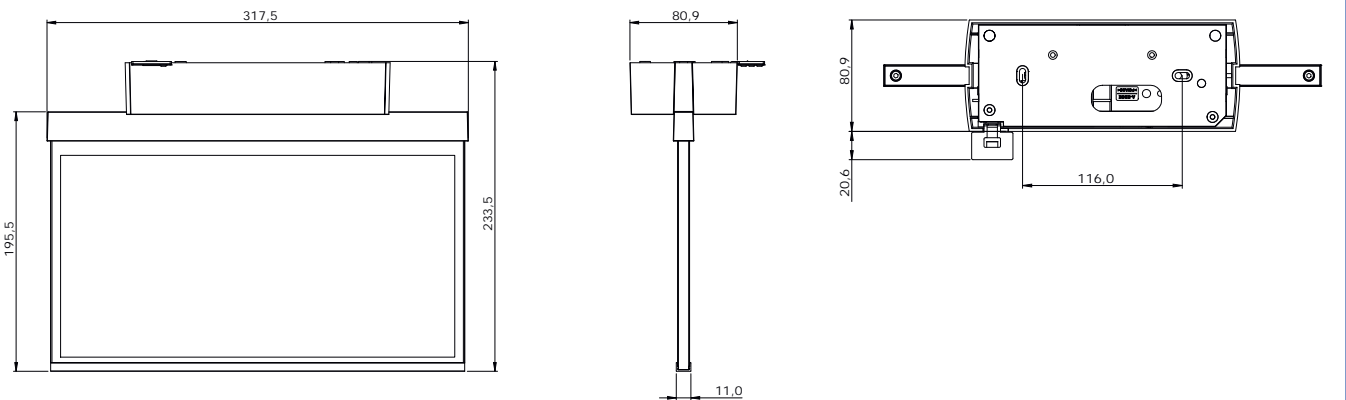

CEILING MOUNTING

Dimensions GABD ceiling mounting

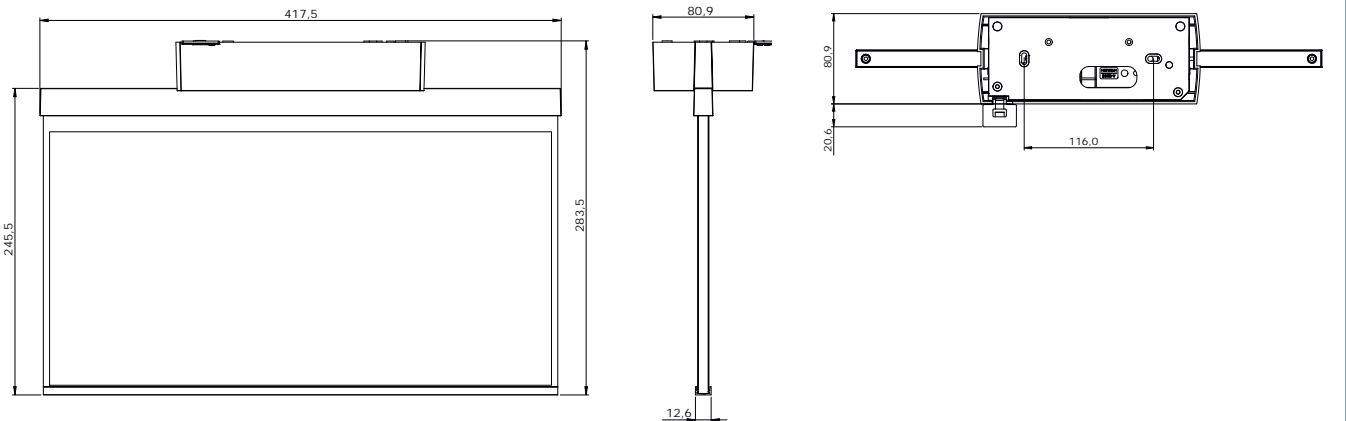

WALL MOUNTING

Dimensions GAMW wall mounting

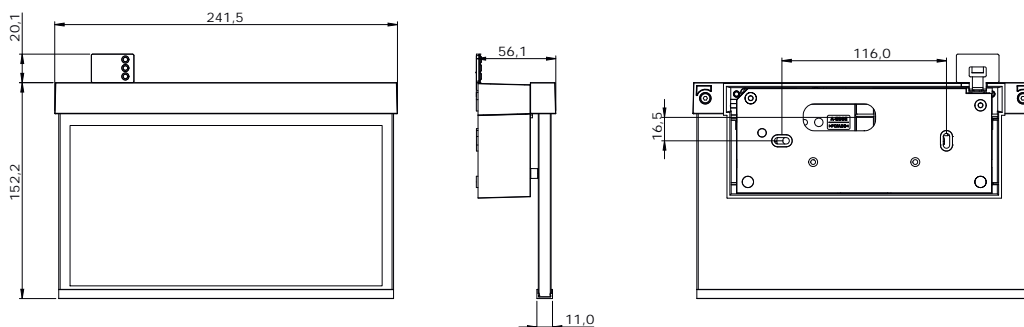

WALL MOUNTING

Dimensions GAXW wall mounting

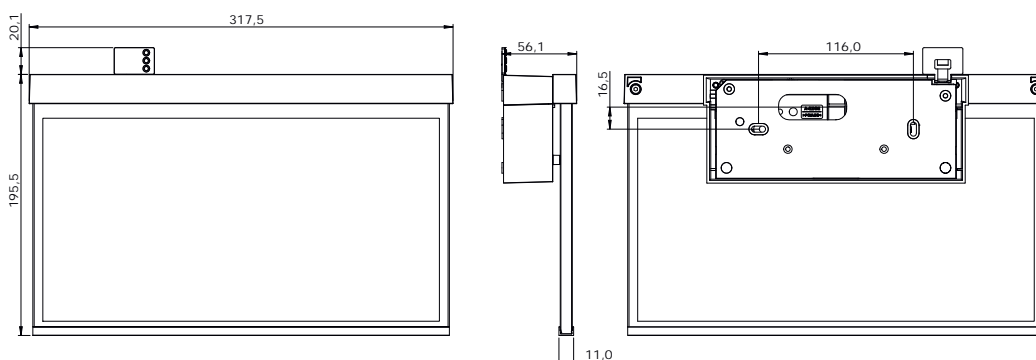

WALL MOUNTING

Dimensions GABW wall mounting

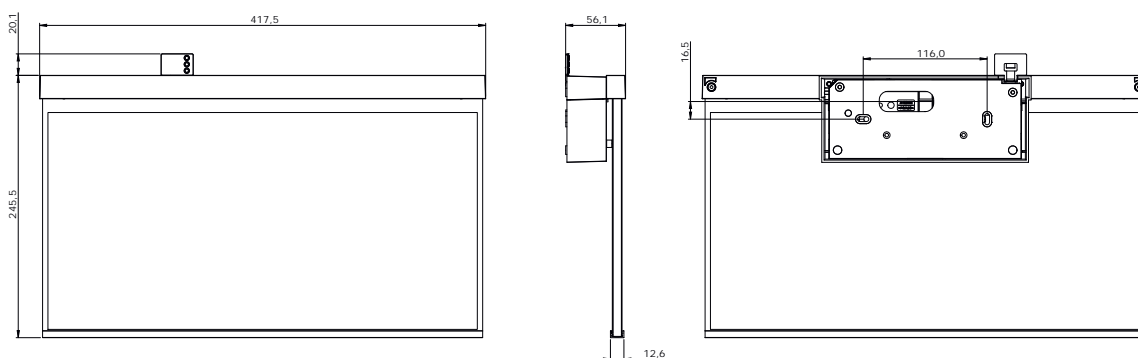

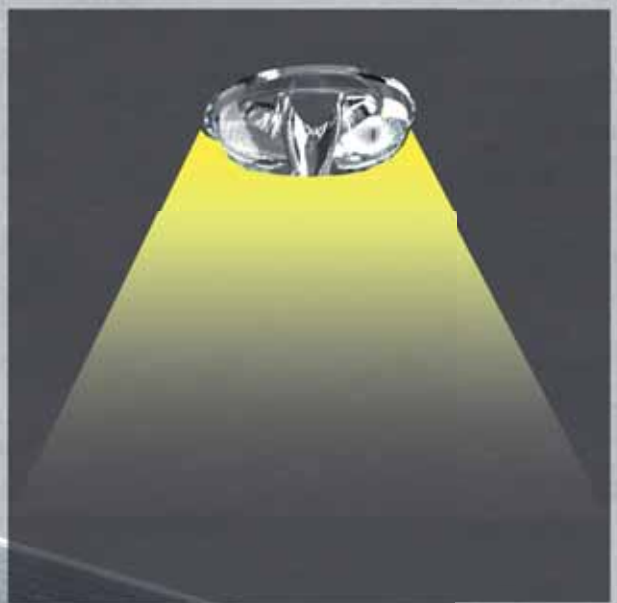
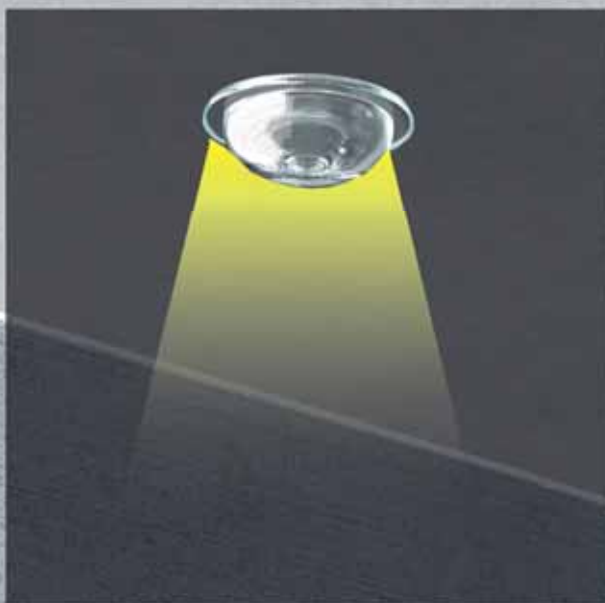

 **EE-Series**
EMERGENCY ROUTE LIGHTING



FACTS

- Zinc die-cast housing
- IP20
- LED Illuminant
- Pluggable corridor or round lens for full flexibility at the installation site
- Ceiling or recessed mounting
- -5° to +40°C

The discreet downlight meets DIN EN 60598-1, DIN EN 60598-22 and DIN EN 1838. Made of zinc die-cast it fits unobtrusively on the ceiling. Besides normal recessed ceiling mounting it can also be mounted in conventional fire protection boxes. The status LED integrated within the lens does not interrupt the harmony of the decent housing. Optimal light distribution and lighting of escape and rescue routes is achieved by use of cluster lenses and powerful ERT LED technology. The EE emergency light is available with round (EERx) or square (EEQx) cover.

The fourth letter marks the type of lense used in the luminaire:

EERR / EEQR

The radiate beam of the EERR / EEQR illuminates the escape and rescue route for ceiling heights up to 4m most effective at intersections of two corridors.

EERF / EEQF

The EERF / EEQF has a lens to focus the light into two main directions. This corridor lights is particularly effective for normal ceiling heights up to 4m and enables luminaire spacing of about 18m in the escape route.

EERS / EEQS

The spot lens of the EERS / EEQS ensures an even distribution of light in all directions, even with ceiling heights over 4m.

EERL / EEQL



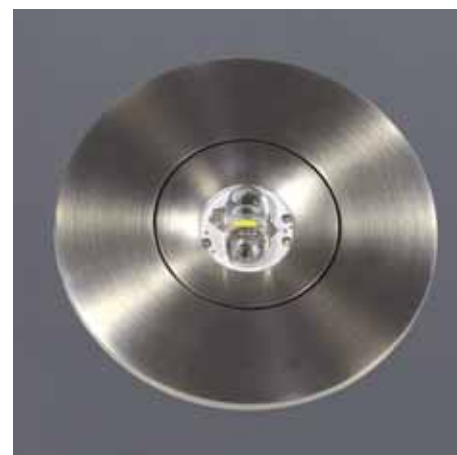













The innovative integrated lens socket with quick-mounting device enables flexible use of different lens types depending on the application. Round and corridor lenses are already included with every luminaire.



EE-Series

EMERGENCY ROUTE LIGHTING

Flexi
Click

							
SELF-CONTAINED LUMINAIRES WITH SELFCONTROL MODULE							
System lens 1h, 230V AC	EEQL431SC *	EERL431SC **	1 h		6,4 W - 470 lm	6,4V/1,2Ah LiFeP04	
System lens 3h, 230V AC	EEQL433SC *	EERL433SC **	3 h		4,2 W - 255 lm	6,4V/1,2Ah LiFeP04	
System lens 8h, 230V AC	EEQL438SC *	EERL438SC **	8 h		7 W - 210 lm	6,4V/3,3Ah LiFePo4	
SELF-CONTAINED LUMINAIRES WITH WIRELESS PROFESSIONAL MODULE (SWITCHABLE)							
System lens 1h, 230V AC	EEQL431WL *	EERL431WL **	1 h		6,4 W - 470 lm	6,4V/1,2Ah LiFeP04	
System lens 3h, 230V AC	EEQL433WL *	EERL433WL **	3 h		6,4 W - 195 lm	6,4V/1,2Ah LiFeP04	
System lens 8h, 230V AC	EEQL438WL *	EERL438WL **	8 h		6,4 W - 80 lm	6,4V/1,2Ah LiFeP04	
LUMINAIRES FOR CORE COMPACT LOW-POWER SYSTEMS 24V AC/DC INCL. MONITORING MODULE							
System lens 24V AC/DC	EEQL529CC *	EERL529CC **	CPS		1,5 W - 140 lm		
System lens 24V AC/DC	EEQL539CC *	EERL539CC **	CPS		3,1 W - 450 lm		
LUMINAIRES FOR CENTRAL BATTERY SYSTEMS AC/DC INCL. MONITORING MODULE							
System lens 230V AC/DC	EEQL029ML *	EERL029ML **	CPS		2,8 W - 140 lm		
System lens 230V AC/DC	EEQL039ML *	EERL039ML **	CPS		4,8 W - 470 lm		

*) Standard: white (RAL 9003) | -AZ: anthracite (RAL 7016)

**) Standard: white (RAL (9003) | -AZ: anthracite (RAL 7016) | -E: stainless steel look (EER only)

ACCESSORIES



LSYS-S: Spotlens for luminaires with lens system. Suitable for ceilings up to 12m.



LSYS-B: Beam lens for luminaires with lens system. To illuminate firefighting and help points on the wall.



LSYS-H: Lens for illuminating corridors with ceiling heights > 4m (4 pieces).



LSYS-WF: Lens for wall-mounted lights for illuminating corridors (4 pcs.)

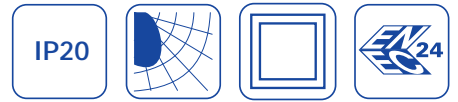

Distance table EExL 431 and EExL 039 with corridor lens for plane emergency routes (additional distance tables on our website)

Montagehöhe (m)					
2.50	3.30	8.67	13.73	18.86	8.55
3.00	3.40	9.04	15.31	21.55	9.70
3.50	3.46	9.33	16.76	24.03	10.71
4.00	3.51	9.55	18.01	26.36	11.31

Distance table EExL 431 and EExL 039 with spot lens for plane emergency routes (additional distance tables on our website)

Montagehöhe (m)					
3.00	2.86	6.62	6.62	6.62	2.86
4.00	3.47	7.77	7.77	7.77	3.47
5.00	4.05	9.09	9.09	9.09	4.05
6.00	4.60	10.17	10.17	10.17	4.60
7.00	5.06	11.39	11.39	11.39	5.06
8.00	5.40	12.52	12.52	12.52	5.40
9.00	5.62	13.52	13.52	13.52	5.62
10.00	5.74	14.39	14.39	14.39	5.74
11.00	5.72	15.10	15.10	15.10	5.72
12.00	5.61	15.60	15.60	15.60	5.61

The distance table is based on the following parameters: Maintenance factor: 0.8; emergency lighting factor 1.00; Minimum illumination on the center line: 1.00 lux; Minimum illumination on the half width of the rescue

route: 0.50 lux, uniformity on the midline maximum 40:1; Width of the rescue route 2.00m

RECESSED CEILING MOUNTING

Dimensions EER / EEQ

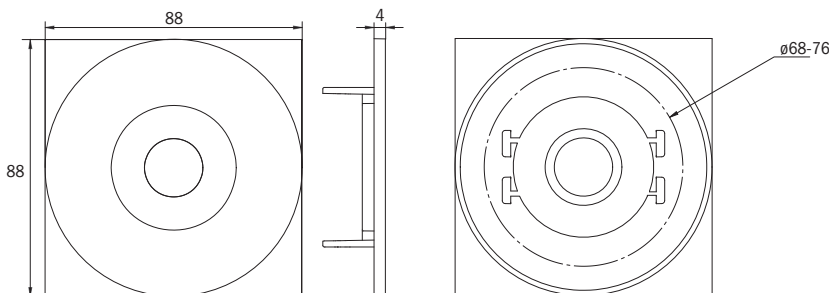

Cut-out EER / EEQ

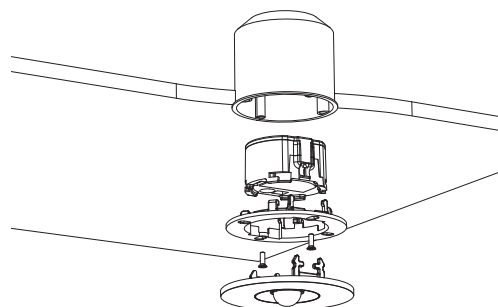
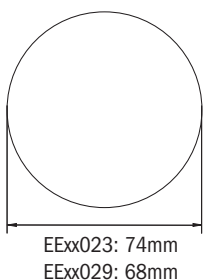

EEx029: Mounting jack necessary (not included in delivery)

SelfContained electronics box (UH-1)

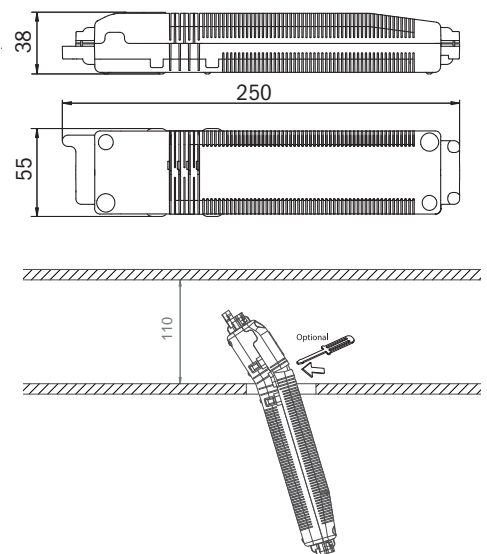

» EE-Series

SOCKET MOUNTING WITH FUNCTION ENDURANCE

Luminaires of the EEx-series fit due to its very compact design also in a standard connection jack or fire resistant jack, such as Kaiser HWD 30. This allows EEx-luminaires to be installed in fire resistant ceilings of classes F30, F60 and F90 according to DIN 4102-4 or DIN 4102-2 as well. No reworking with fire protection silicone and no additional fire protection housing necessary.

To mount the central battery luminaire in a jack, the lateral ceiling clamps have to be removed and the included adapter ring must be applied (art.-no. EE-EBA).

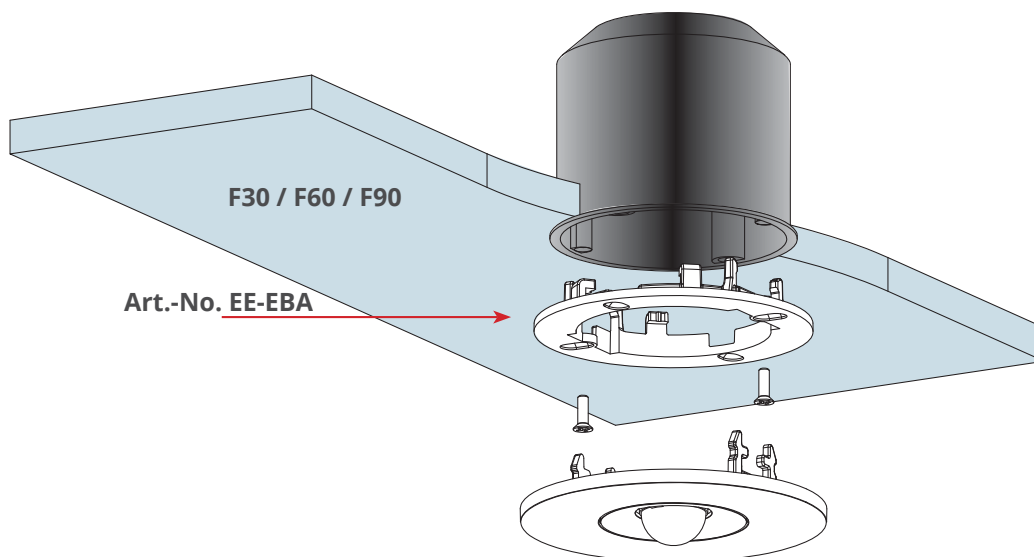



MODULES

ACCESSORIES

WIRELESS MONITORING

GENERAL LIGHTING
WITH EMERGENCY LIGHT

INDUSTRIAL
LUMINAIRES

UNIVERSAL
LUMINAIRES

DYNAMIC
LUMINAIRES

DESIGN LUMINAIRES

GENERAL
INFORMATIONS

EA-Series

EMERGENCY ROUTE LIGHTING

FACTS

- Zinc die-cast housing
- IP40
- LED Illuminant
- ceiling mounting
- -5° to +40°C

Universal, discreet Zinc die-cast ceiling-mounting cover for the lights ILDR, ILDF and ILDS. For easier installation, the housing can be assembled later.

By using the light IL as a base, you have the advantage of compact storage.

Version	Order numbers
Covers	
Round cover	
... - white	EAR
... - anthracite	EAR-AZ
Square cover	
... - white	EAQ
... - anthracite	EAQ-AZ

CEILING MOUNTING

Dimensions and drilling distances EAR / EAQ

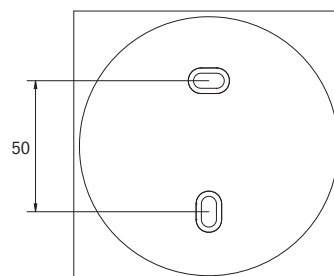
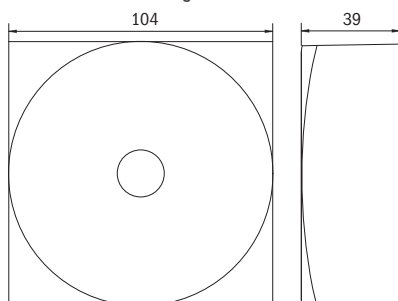

All Dimensions in mm



EAR



EAQ-AZ



SELF-CONTAINED LUMINAIRES WITH SELFCONTROL MODULE								
System lens 1h, 230V AC	EAQL421SC	EAQL421SC-AZ	EARL421SC	EARL421SC-AZ	1 h	3 W - 250 lm	3,2V / 3,3 Ah LiFePO ₄	
System lens 3h, 230V AC	EAQL423SC	EAQL423SC-AZ	EARL423SC	EARL423SC-AZ	3 h	3 W - 250 lm	3,2V / 3,3 Ah LiFePO ₄	
System lens 8h, 230V AC	EAQL428SC	EAQL428SC-AZ	EARL428SC	EARL428SC-AZ	8 h	3 W - 125 lm	3,2V / 3,3 Ah LiFePO ₄	
SELF-CONTAINED LUMINAIRES WITH WIRELESS BASIC MODULE								
System lens 1h, 230V AC	EAQL421WB	EAQL421WB-AZ	EARL421WB	EARL421WB-AZ	1 h	3,4 W - 250 lm	3,2V / 3,3 Ah LiFePO ₄	
System lens 3h, 230V AC	EAQL423WB	EAQL423WB-AZ	EARL423WB	EARL423WB-AZ	3 h	3,4 W - 250 lm	3,2V / 3,3 Ah LiFePO ₄	
System lens 8h, 230V AC	EAQL428WB	EAQL428WB-AZ	EARL428WB	EARL428WB-AZ	8 h	3,4 W - 125 lm	3,2V / 3,3 Ah LiFePO ₄	
SELF-CONTAINED LUMINAIRES WITH WIRELESS PROFESSIONAL MODULE (SWITCHABLE)								
System lens 1h, 230V AC	EAQL421WL	EAQL421WL-AZ	EARL421WL	EARL421WL-AZ	1 h	3,4 W - 250 lm	3,2V / 3,3 Ah LiFePO ₄	
System lens 3h, 230V AC	EAQL423WL	EAQL423WL-AZ	EARL423WL	EARL423WL-AZ	3 h	3,4 W - 250 lm	3,2V / 3,3 Ah LiFePO ₄	
System lens 8h, 230V AC	EAQL428WL	EAQL428WL-AZ	EARL428WL	EARL428WL-AZ	8 h	3,4 W - 125 lm	3,2V / 3,3 Ah LiFePO ₄	
LUMINAIRES FOR CORE COMPACT LOW-POWER SYSTEMS 24V AC/DC INCL. MONITORING MODULE								
System lens 24V AC/DC	EAQL529CC	EAQL529CC-AZ	EARL529CC	EARL529CC-AZ	CPS	2,8 W - 360 lm		
LUMINAIRES FOR CENTRAL BATTERY SYSTEMS AC/DC INCL. MONITORING MODULE								
System lens 230V AC/DC	EAQL029ML	EAQL029ML-AZ	EARL029ML	EARL029ML-AZ	CPS	4,6 W - 360 lm		

*) Standard: white | -AZ: anthracite

ACCESSORIES



LSYS-S: Spotlens for luminaires with lens system. Suitable for ceilings up to 12m.



LSYS-B: Beam lens for luminaires with lens system. To illuminate firefighting and help points on the wall.



LSYS-H: Lens for illuminating corridors with ceiling heights > 4m (4 pieces).



LSYS-WF: Lens for wall-mounted lights for illuminating corridors (4 pcs.)



 **DDE**
EMERGENCY ROUTE LIGHTING



FACTS

- Zinc die-cast
- IP40
- Power LED illuminant
- Recessed mounting
- -10 to +40°C

The high-performance LED safety light complies with the emergency lighting requirements of DIN EN 60598-1, DIN EN 60598-2-22 and DIN EN 1838.

The luminaire is particularly suitable for installation in high ceilings. Due to the high light output, it can also provide the necessary safety lighting for workplaces with a particular risk.

Both the radiator and the heat sink are made of high-quality die-cast zinc. The material used ensures good heat dissipation and a long service life of the LED.

The tension springs mounted on the product make assembly much easier. Another plus point is its small installation dimensions, with a minimum ceiling cut-out of just 68mm.

LUMINAIRES FOR CENTRAL BATTERY SYSTEMS AC/DC INCL. MONITORING MODULE				
LED, 230V AC/DC	DDE039ML	CPS	9,6 W - 1100 lm	

RECESSED CEILING MOUNTING

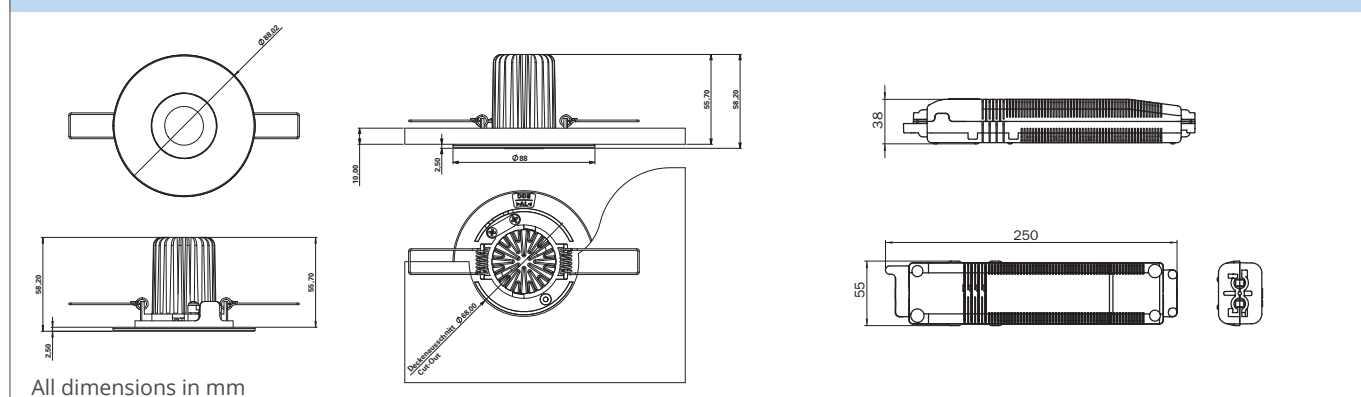

Distance Table for DDE039ML for plane emergency routes (additional distance tables on our website)

Mounting height (m)					
2.50	4.98	10.98	10.62	10.37	4.78
3.00	5.66	12.52	12.25	11.98	5.45
3.50	6.26	14.02	13.74	13.45	6.04
4.00	6.78	15.39	15.09	14.80	6.56
4.50	7.21	16.65	16.35	16.04	7.04
5.00	7.59	17.83	17.51	17.19	7.47
5.50	7.94	18.89	18.55	18.25	7.86
6.00	8.08	19.78	19.49	19.24	8.03
6.50	8.13	20.61	20.37	20.16	8.17
7.00	8.15	21.38	21.18	21.01	8.27

The distance table is based on the following parameters: Maintenance factor: 0.8; emergency lighting factor 1.00; Minimum illumination on the center line: 1.00 lux; Minimum illumination on the half width of the rescue

route: 0.50 lux, uniformity on the midline maximum 40:1; Width of the rescue route 2.00m



 **FMW**
ZINC DIE-CAST EXIT SIGN



FACTS

- Zinc die-cast housing, white (RAL 9003) or anthracite (RAL 7016)
- IP65
- LED Illuminant
- wall mounting
- Self-Contained: -5° to +40°C
Central battery systems: -20° to +40°C

Robust wall-mounted Zinc die-cast luminaire for the lighting of escape and rescue routes according to DIN EN 60598-1, DIN EN 605982-22 and EN 1838. Appealing design with concealed screws.

Available for central power systems or as LED self-contained emergency luminaire.



(CBS-Version)

SELF-CONTAINED LUMINAIRES WITH SELFCONTROL MODULE					
LED, 1h, 230V AC	FMW401SC	FMW401SC-AZ	1 h	3,9 W	6,4V/1,2Ah LiFePO4
LED, 3h, 230V AC	FMW403SC	FMW403SC-AZ	3 h	3,9 W	6,4V/1,2Ah LiFePO4
LED, 8h, 230V AC	FMW408SC	FMW408SC-AZ	8 h	4,2 W	6,4V/3,3Ah LiFePO4
SELF-CONTAINED LUMINAIRES WITH WIRELESS PROFESSIONAL MODULE (SWITCHABLE)					
LED, 1h, 230V AC	FMW401WL	FMW401WL-AZ	1 h	3,9 W	6,4V/1,2Ah LiFePO4
LED, 3h, 230V AC	FMW403WL	FMW403WL-AZ	3 h	3,9 W	6,4V/1,2Ah LiFePO4
LED, 8h, 230V AC	FMW408WL	FMW408WL-AZ	8 h	4,6 W	6,4V/3,3Ah LiFePO4
LUMINAIRES FOR CORE COMPACT LOW-POWER SYSTEMS 24V AC/DC INCL. MONITORING MODULE					
LED, 24V, AC/DC	FMW509CC	FMW509CC-AZ	CPS	2,2 W	
LUMINAIRES FOR CENTRAL BATTERY SYSTEMS AC/DC INCL. MONITORING MODULE					
LED, 230V AC/DC	FMW009ML	FMW009ML-AZ	CPS	3,4 W	

WALL MOUNTING

Dimensions and drilling distances

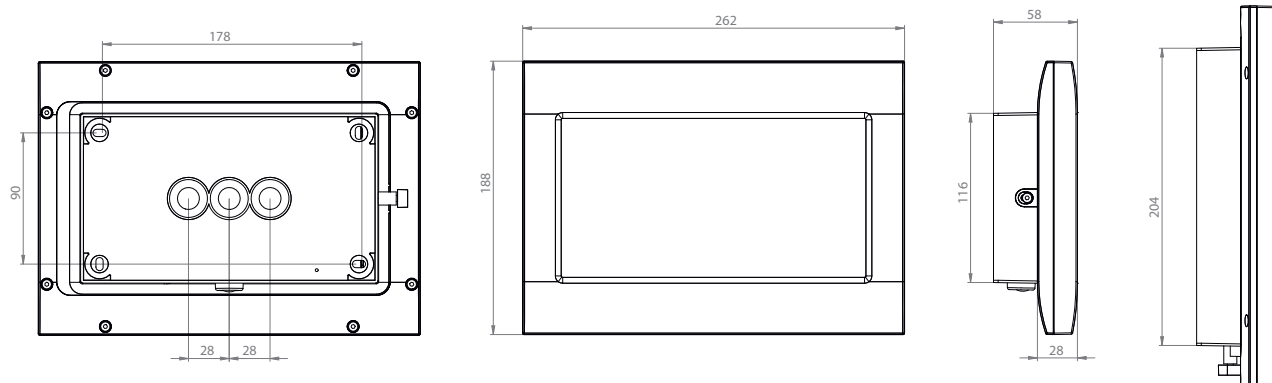



FMDS

ZINC DIE-CAST EMERGENCY LUMINAIRE



FACTS

- Zinc die-cast housing, white or anthracite
- IP65
- LED Illuminant
- ceiling mounting
- -5° to +40°C

Robuste Aufbauleuchte aus Zink Druckguss zur Ausleuchtung der Flucht- und Rettungswege nach DIN EN 60598-1, DIN EN 60598-2-22 und DIN EN 1838.

Ansprechendes Design durch verdeckte Verschraubung. Erhältlich als CPS- oder LED-Einzelbatterie-Leuchte. Ballwurfsicher nach DIN 18032.



SELF-CONTAINED LUMINAIRES WITH SELFCONTROL MODULE						
LED, 1h, 230V AC	FMDS421SC	FMDS421SC-AZ	1 h	6,4 W - 520 lm	6,4V/1,6Ah LiFeP04	
LED, 3h, 230V AC	FMDS423SC	FMDS423SC-AZ	3 h	6,7 W - 500 lm	6,4V/3,3Ah LiFeP04	
LED, 8h, 230V AC	FMDS428SC	FMDS428SC-AZ	8 h	6,7 W - 500 lm	6,4V/3,3Ah LiFeP04	
SELF-CONTAINED LUMINAIRES WITH WIRELESS PROFESSIONAL MODULE (SWITCHABLE)						
LED, 1h, 230V AC	FMDS421WL	FMDS421WL-AZ	1 h	7,5 W - 460 lm	6,4V/1,2Ah LiFeP04	
LED, 3h, 230V AC	FMDS423WL	FMDS423WL-AZ	3 h	7,5 W - 520 lm	6,4V/3,3Ah LiFeP04	
LED, 8h, 230V AC	FMDS428WL	FMDS428WL-AZ	8 h	7,5 W - 245 lm	6,4V/3,3Ah LiFeP04	
LUMINAIRES FOR CORE COMPACT LOW-POWER SYSTEMS 24V AC/DC INCL. MONITORING MODULE						
LED, 24V AC/DC	FMDS529CC	FMDS529CC-AZ	CPS	3,8 W - 520 lm		
LUMINAIRES FOR CENTRAL BATTERY SYSTEMS AC/DC						
LED, 230V AC/DC	FMDS029	FMDS029-AZ	CPS	4,6 W - 520 lm		
LUMINAIRES FOR CENTRAL BATTERY SYSTEMS AC/DC INCL. MONITORING MODULE						
LED, 230V AC/DC	FMDS029ML	FMDS029ML-AZ	CPS	5,2 W - 520 lm		

Distance table FMDS029(ML) for plane emergency routes

Mounting height (m)					
2.00	4.29	9.63	8.77	6.96	2.86
2.50	4.91	11.50	10.47	8.15	3.20
3.00	5.41	12.74	11.61	8.64	3.33
3.50	5.82	13.99	12.61	9.09	3.50
4.00	6.40	15.13	13.55	9.45	3.60
5.00	7.14	17.12	15.28	10.10	3.76
6.00	7.96	19.04	16.72	10.62	3.90
7.00	8.34	20.68	17.90	11.00	3.88
8.00	8.88	22.10	18.84	11.24	3.90
9.00	9.00	23.34	19.29	11.40	3.81
10.50	8.49	24.87	19.35	11.40	3.42
12.00	7.80	25.47	18.75	11.16	3.00

The distance table is based on the following parameters: Maintenance factor: 0.8; emergency lighting factor 1.00; Minimum illumination on the center line: 1.00 lux; Minimum illumination on the half width of the rescue

route: 0.50 lux, uniformity on the midline maximum 40:1; Width of the rescue route 2.00m



 **WEF**
RECESSED WALL MOUNTED LUMINAIRE



FACTS

- Zinc die-cast, white, anthracite or stainless steel look
- IP20
- LED Illuminant
- Recessed wall mounting
- -10° to +40°C

LED emergency luminaire for wall installation and for the lighting of escape and rescue routes according to DIN EN 60598-1, DIN EN 605982-22 and DIN EN 1838.

This recessed luminaire is designed for installation in conventional installation jacks. The mounting frame can be aligned with the jacks.

The zinc die-cast cover is locked without externally visible fastening. Through the status LED which is incorporated in the lens the harmony of the housing is not interrupted.

SELF-CONTAINED LUMINAIRES WITH SELFCONTROL MODULE							
LED, 1h, 230V AC	WEF421SC *	WEF421SC-AZ *	WEF421SC-E *	1 h	5,4 W - 420 lm	6,4V/1,6Ah LiFeP04	
LED, 3h, 230V AC	WEF423SC *	WEF423SC-AZ *	WEF423SC-E *	3 h	6,1 W - 420 lm	6,4V/1,6Ah LiFeP04	
LED, 8h, 230V AC	WEF428SC *	WEF428SC-AZ *	WEF428SC-E *	8 h	6,1 W - 270 lm	6,4V/1,6Ah LiFeP04	
SELF-CONTAINED LUMINAIRES WITH WIRELESS PROFESSIONAL MODULE (SWITCHABLE)							
LED, 1h, 230V AC	WEF421WL *	WEF421WL-AZ *	WEF421WL-E *	1 h	5,1 W - 420 lm	6,4V/1,2Ah LiFeP04	
LED, 3h, 230V AC	WEF423WL *	WEF423WL-AZ *	WEF423WL-E *	3 h	5,1 W - 315 lm	6,4V/1,2Ah LiFeP04	
LED, 8h, 230V AC	WEF428WL *	WEF428WL-AZ *	WEF428WL-E *	8 h	5,1 W - 75 lm	6,4V/1,2Ah LiFeP04	
LUMINAIRES FOR CORE COMPACT LOW-POWER SYSTEMS 24V AC/DC INCL. MONITORING MODULE							
LED, 24V AC/DC	WEF529CC *	WEF529CC-AZ *	WEF529CC-E *	CPS	3,3 W - 420 lm		
LUMINAIRES FOR CENTRAL BATTERY SYSTEMS AC/DC							
LED, 230V AC/DC	WEF029 *	WEF029-AZ *	WEF029-E *	CPS	3,9 W - 420 lm		
LUMINAIRES FOR CENTRAL BATTERY SYSTEMS AC/DC INCL. MONITORING MODULE							
LED, 230V AC/DC	WEF029ML *	WEF029ML-AZ *	WEF029ML-E *	CPS	4,3 W - 420 lm		

*) Supplied with UH1 housing. Contents may exceed the volume of the installation box.

RECESSED WALL MOUNTING

WEF Dimensions

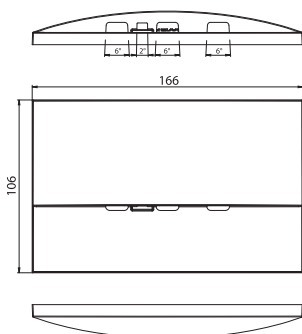

All Dimensions in mm

SelfContained electronics box (optional)

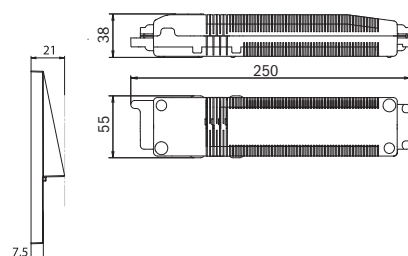

WEF 029(ML) installation socket

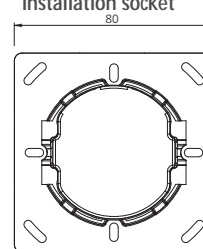

WEF Illumination

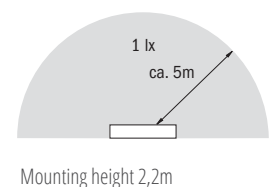
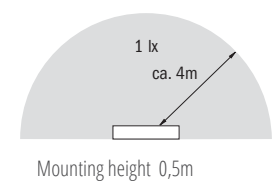



 **WER**
EMERGENCY ROUTE LIGHTING



FACTS

- Zinc die-cast, white, anthracite or stainless steel look
- IP20
- LED Illuminant
- Recessed wall mounting
- -10° to +40°C

LED emergency luminaire for wall installation for the lighting of escape and rescue routes according to DIN EN 60598-1, DIN EN 60598-2-22 and DIN EN 1838.

The discreet recessed luminaire is designed for installation in conventional jacks. The mounting frame can be aligned with the jack.

The zinc die-cast cover is locked without externally visible fastening. Through the status LED incorporated in the lens the harmony of the housing is not interrupted.

SELF-CONTAINED LUMINAIRES WITH SELFCONTROL MODULE							
LED, 1h, 230V AC	WER021SC *	WER021SC-AZ *	WER021SC-E *	1 h	3,1 W - 140 lm	4,8V/2,0Ah NiMH	
LED, 3h, 230V AC	WER023SC *	WER023SC-AZ *	WER023SC-E *	3 h	3,1 W - 140 lm	4,8V/2,0Ah NiMH	
LED, 8h, 230V AC	WER028SC *	WER028SC-AZ *	WER028SC-E *	8 h	3,1 W - 120 lm	4,8V/2,0Ah NiMH	
SELF-CONTAINED LUMINAIRES WITH WIRELESS PROFESSIONAL MODULE (SWITCHABLE)							
LED, 1h, 230V AC	WER021WL *	WER021WL-AZ *	WER021WL-E *	1 h	5,6 W - 140 lm	4,8V/2,0Ah NiMH	
LED, 3h, 230V AC	WER023WL *	WER023WL-AZ *	WER023WL-E *	3 h	5,6 W - 140 lm	4,8V/2,0Ah NiMH	
LUMINAIRES FOR CORE COMPACT LOW-POWER SYSTEMS 24V AC/DC INCL. MONITORING MODULE							
LED, 24V AC/DC	WER529CC *	WER529CC-AZ *	WER529CC-E *	CPS	1,5 W - 140 lm		
LUMINAIRES FOR CENTRAL BATTERY SYSTEMS AC/DC							
LED, 230V AC/DC	WER029 *	WER029-AZ *	WER029-E *	CPS	1,9 W - 140 lm		
LUMINAIRES FOR CENTRAL BATTERY SYSTEMS AC/DC INCL. MONITORING MODULE							
LED, 230V AC/DC	WER029ML *	WER029ML-AZ *	WER029ML-E *	CPS	2,1 W - 140 lm		

*) Delivered with 1 UH-housing. Content may exceed the volume of the installation socket..

RECESSED WALL MOUNTING

WER Dimensions

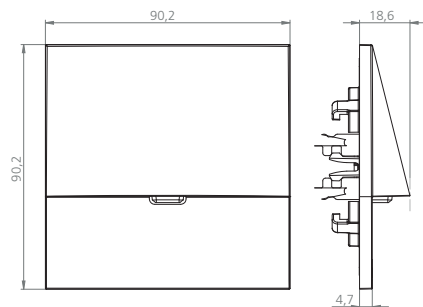

SelfContained electronics box

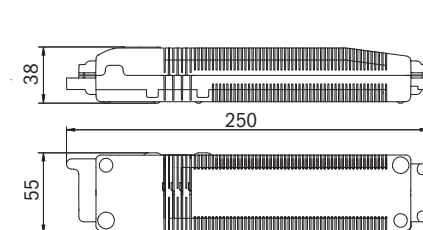

WER 029ML installation socket

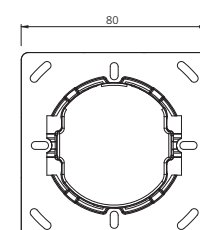

All Dimensions in mm

WER Illumination

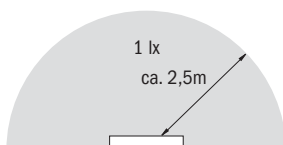

Mounting height 0,5m

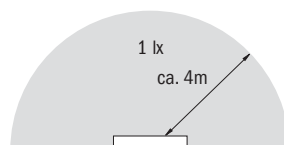

Mounting height 2m



 **WAF**
EMERGENCY ROUTE LIGHTING



FACTS

- Zinc die-cast, white, anthracite or stainless steel look
- IP20
- LED Illuminant
- wall mounting
- -10° to +40°C

LED emergency luminaire for surface wall mounting and for the lighting of escape and rescue routes according to DIN EN 60598-1, DIN EN 60598-2-22 and DIN EN 1838.

This luminaire is the perfect solution if a recessed mounting of a WEF or WER luminaire is not possible.

SELF-CONTAINED LUMINAIRES WITH SELFCONTROL MODULE							
LED, 1h, 230V AC	WAF421SC	WAF421SC-AZ	WAF421SC-E	1 h	5,4 W - 420 lm	6,4V/1,2Ah LiFeP04	
LED, 3h, 230V AC	WAF423SC	WAF423SC-AZ	WAF423SC-E	3 h	3,7 W - 230 lm	6,4V/1,2Ah LiFeP04	
LED, 8h, 230V AC	WAF428SC	WAF428SC-AZ	WAF428SC-E	8 h	5 W - 140 lm	6,4V/1,2Ah LiFeP04	
SELF-CONTAINED LUMINAIRES WITH WIRELESS PROFESSIONAL MODULE (SWITCHABLE)							
LED, 1h, 230V AC	WAF421WL	WAF421WL-AZ	WAF421WL-E	1 h	5,1 W - 420 lm	6,4V/1,2Ah LiFeP04	
LED, 3h, 230V AC	WAF423WL	WAF423WL-AZ	WAF423WL-E	3 h	5,1 W - 315 lm	6,4V/1,2Ah LiFeP04	
LED, 8h, 230V AC	WAF428WL	WAF428WL-AZ	WAF428WL-E	8 h	5,1 W - 75 lm	6,4V/1,2Ah LiFeP04	
LUMINAIRES FOR CORE COMPACT LOW-POWER SYSTEMS 24V AC/DC INCL. MONITORING MODULE							
LED, 24V AC/DC	WAF529CC	WAF529CC-AZ	WAF529CC-E	CPS	3,1 W - 420 lm		
LUMINAIRES FOR CENTRAL BATTERY SYSTEMS AC/DC							
LED, 230V AC/DC	WAF029	WAF029-AZ	WAF029-E	CPS	3,9 W - 420 lm		
LUMINAIRES FOR CENTRAL BATTERY SYSTEMS AC/DC INCL. MONITORING MODULE							
LED, 230V AC/DC	WAF029ML	WAF029ML-AZ	WAF029ML-E	CPS	4,5 W - 420 lm		

WALL MOUNTING

WAF Dimensions

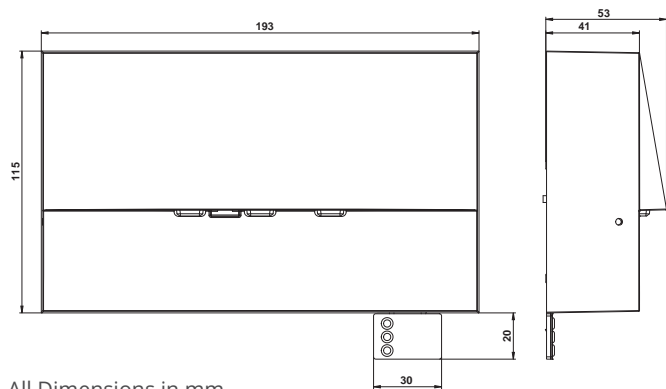

All Dimensions in mm

WAF Illumination

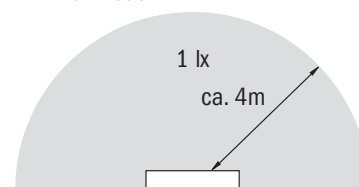

Mounting height 0,5m

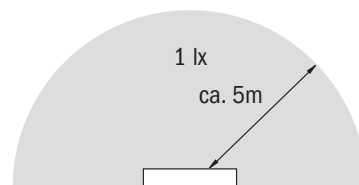

Mounting height 2,2m



 **ZAW**
EMERGENCY ROUTE LIGHTING



FACTS

- Zinc die-cast housing, white or anthracite
- IP65
- LED Illuminant
- wall mounting
- Permissible temperatures: -25°C to +40°C



Robust wall-mounted Zinc die-cast luminaire for the lighting of escape and rescue routes in exit areas according to DIN EN 60598-1, DIN EN 60598-2-22 and EN 1838. Appealing design with concealed screws.

Available for central power systems or as a LED self-contained emergency luminaire.

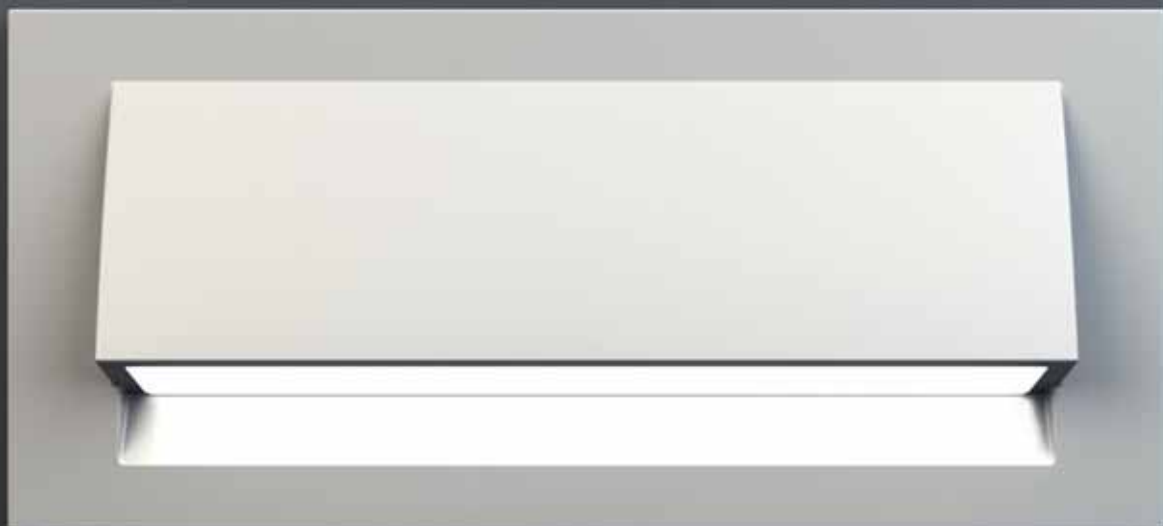

EMERGENCY ROUTE LIGHTING

SELF-CONTAINED LUMINAIRES WITH SELFCONTROL MODULE						
LED, 1h, 230V AC	ZAW411SC-TT	ZAW411SC-TT-AZ	1 h	4,6 W - 190 lm	3,2V / 3,3 Ah LiFePO4 Low temperature	
LED, 3h, 230V AC	ZAW413SC-TT	ZAW413SC-TT-AZ	3 h	4,6 W - 190 lm	3,2V / 3,3 Ah LiFePO4 Low temperature	
LED, 8h, 230V AC	ZAW418SC-TT	ZAW418SC-TT-AZ	8 h	4,6 W - 85 lm	3,2V / 3,3 Ah LiFePO4 Low temperature	
SELF-CONTAINED LUMINAIRES WITH WIRELESS BASIC MODULE						
LED, 1h, 230V AC	ZAW411WB-TT	ZAW411WB-TT-AZ	1 h	5,3 W - 190 lm	3,2V / 3,3 Ah LiFePO4 Low temperature	
LED, 3h, 230V AC	ZAW413WB-TT	ZAW413WB-TT-AZ	3 h	5,3 W - 190 lm	3,2V / 3,3 Ah LiFePO4 Low temperature	
LED, 8h, 230V AC	ZAW418WB-TT	ZAW418WB-TT-AZ	8 h	5,3 W - 85 lm	3,2V / 3,3 Ah LiFePO4 Low temperature	
SELF-CONTAINED LUMINAIRES WITH WIRELESS PROFESSIONAL MODULE (SWITCHABLE)						
LED, 1h, 230V AC	ZAW411WL-TT	ZAW411WL-TT-AZ	1 h	5,3 W - 190 lm	3,2V / 3,3 Ah LiFePO4 Low temperature	
LED, 3h, 230V AC	ZAW413WL-TT	ZAW413WL-TT-AZ	3 h	5,3 W - 190 lm	3,2V / 3,3 Ah LiFePO4 Low temperature	
LED, 8h, 230V AC	ZAW418WL-TT	ZAW418WL-TT-AZ	8 h	5,3 W - 85 lm	3,2V / 3,3 Ah LiFePO4 Low temperature	
LUMINAIRES FOR CORE COMPACT LOW-POWER SYSTEMS 24V AC/DC INCL. MONITORING MODULE						
LED, 24V AC/DC	ZAW519CC	ZAW519CC-AZ	CPS	2,1 W - 220 lm		
LUMINAIRES FOR CENTRAL BATTERY SYSTEMS AC/DC INCL. MONITORING MODULE						
LED, 230V AC/DC	ZAW019ML	ZAW019ML-AZ	CPS	3,2 W - 220 lm		



All self-contained luminaires with new LiFePO4 battery, which allows use at temperatures from -25°C to +40°C. The previous external battery housing is no longer required.

WALL MOUNTING

Dimensions ZAW

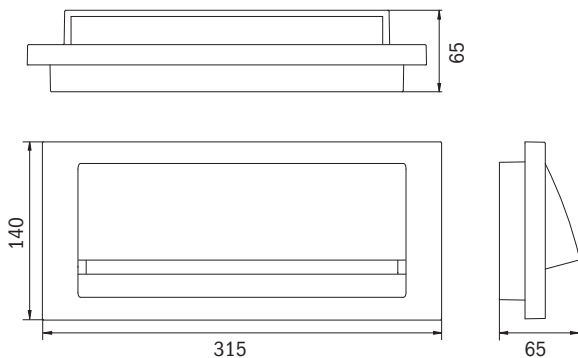

Drilling distances ZAW

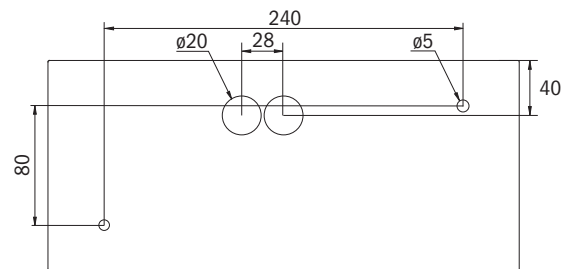

All Dimensions in mm



For applications outside the temperature range of -25° to +40°C (e.g. in direct sunlight).
Outdoor areas), the previous variants with external battery housings in IP20 or IP54 are still available.

SELF-CONTAINED LUMINAIRES WITH SELFCONTROL MODULE									
LED, 1h, 230V AC	ZAW011SC-COOL*	ZAW011SC-COOL-AZ*	1 h		4,6 W - 190 lm	3,2V / 3,3 Ah LiFePO4			
LED, 3h, 230V AC	ZAW013SC-COOL*	ZAW013SC-COOL-AZ*	3 h		4,6 W - 190 lm	3,2V / 3,3 Ah LiFePO4			
LED, 8h, 230V AC	ZAW018SC-COOL*	ZAW018SC-COOL-AZ*	8 h		4,6 W - 85 lm	3,2V / 3,3 Ah LiFePO4			
SELF-CONTAINED LUMINAIRES WITH WIRELESS BASIC MODULE									
LED, 1h, 230V AC	ZAW011WB-COOL*	ZAW011WB-COOL-AZ*	1 h		5,3 W - 190 lm	3,2V / 3,3 Ah LiFePO4			
LED, 3h, 230V AC	ZAW013WB-COOL*	ZAW013WB-COOL-AZ*	3 h		5,3 W - 190 lm	3,2V / 3,3 Ah LiFePO4			
LED, 8h, 230V AC	ZAW018WB-COOL*	ZAW018WB-COOL-AZ*	8 h		5,3 W - 85 lm	3,2V / 3,3 Ah LiFePO4			
SELF-CONTAINED LUMINAIRES WITH WIRELESS PROFESSIONAL MODULE (SWITCHABLE)									
LED, 1h, 230V AC	ZAW011WL-COOL*	ZAW011WL-COOL-AZ*	1 h		5,3 W - 190 lm	3,2V / 3,3 Ah LiFePO4			
LED, 3h, 230V AC	ZAW013WL-COOL*	ZAW013WL-COOL-AZ*	3 h		5,3 W - 190 lm	3,2V / 3,3 Ah LiFePO4			
LED, 8h, 230V AC	ZAW018WL-COOL*	ZAW018WL-COOL-AZ*	8 h		5,3 W - 85 lm	3,2V / 3,3 Ah LiFePO4			

* - Please specify protection class for the battery housing: IP20 or IP54.

WALL MOUNTING

External battery housing

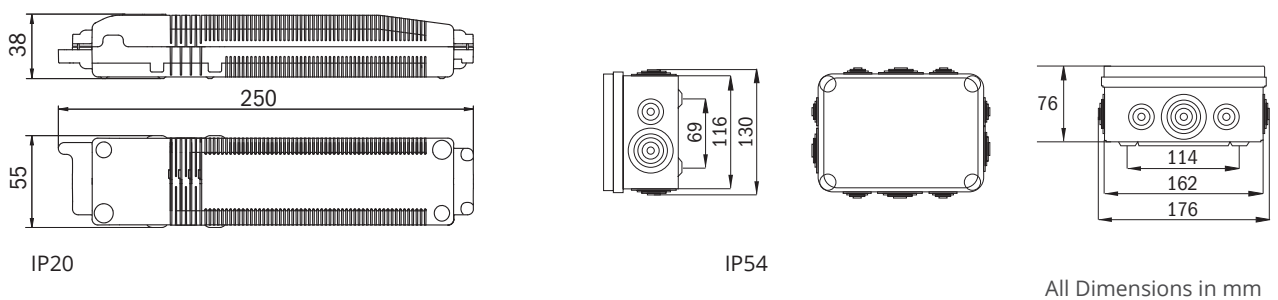

Distance table ZAW411SC, ZAW413SC (-COOL) for plane emergency routes

Mounting height (m)					
2.00	2.18	4.38	7.96	6.51	0.00
2.50	2.35	4.70	8.76	6.88	0.00
3.00	2.45	4.91	9.44	7.13	0.00
3.50	2.49	4.99	8.52	7.40	0.00
4.00	2.45	4.91	7.70	7.48	0.00

The distance table is based on the following parameters: Maintenance factor: 0.8; emergency lighting factor 1.00; Minimum illumination on the center line: 1.00 lux; Minimum illumination on the half width of the rescue

route: 0.50 lux, uniformity on the midline maximum 40:1; Width of the rescue route 2.00m

*) For luminaires with metal housing the wireless range may be reduced by 20%



UEMR

RECESSED WALL LUMINAIRE



FACTS

- Wall-even recessed luminaire
- IP40
- 20m Recognition distance
- Complete set of pictographs (ISO 7010)
- Permissible temperatures: -5°C to +40°C

Frameless and flush-mounted LED escape sign luminaire for wall installation. A light that is optimally integrated into the wall, with no frame, screws or protruding parts that affect the design of the surroundings.

A clever leveling system is already integrated and makes it easy to align the light exactly to the level of the wall.

The pictogram set is inserted inside and attached without solvents.

SELF-CONTAINED LUMINAIRES WITH SELFCONTROL MODULE					
LED, 1h, 230V AC	UEMR401SC	1 h		6,4V/1,2Ah LiFeP04	
LED, 3h, 230V AC	UEMR403SC	3 h		6,4V/1,2Ah LiFeP04	
LED, 8h, 230V AC	UEMR408SC	8 h		6,4V/3,3Ah LiFeP04	
SELF-CONTAINED LUMINAIRES WITH WIRELESS PROFESSIONAL MODULE (SWITCHABLE)					
LED, 1h, 230V AC	UEMR401WL	1 h		6,4V/1,2Ah LiFeP04	
LED, 3h, 230V AC	UEMR403WL	3 h		6,4V/1,2Ah LiFeP04	
LED, 8h, 230V AC	UEMR408WL	8 h		6,4V/3,3Ah LiFeP04	
LUMINAIRES FOR CORE COMPACT LOW-POWER SYSTEMS 24V AC/DC INCL. MONITORING MODULE					
LED, 24V, AC/DC	UEMR509CC	CPS			
LUMINAIRES FOR CENTRAL BATTERY SYSTEMS AC/DC INCL. MONITORING MODULE					
LED, 230V AC/DC	UEMR019ML	CPS			

RECESSED WALL MOUNTING

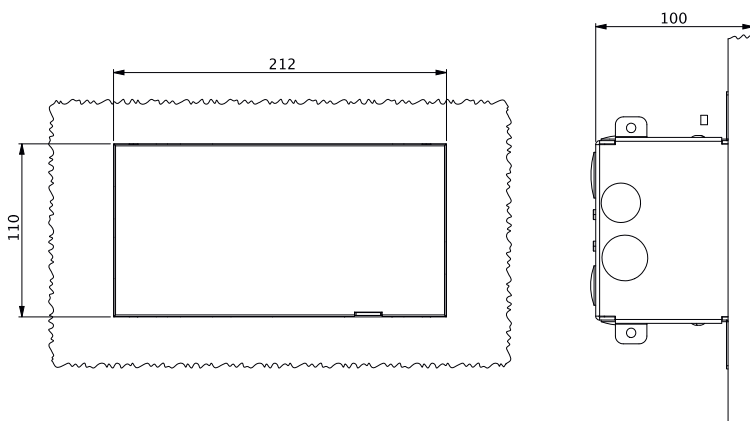

All Dimensions in mm



 **DYNAMIC EXIT LUMINAIRE**

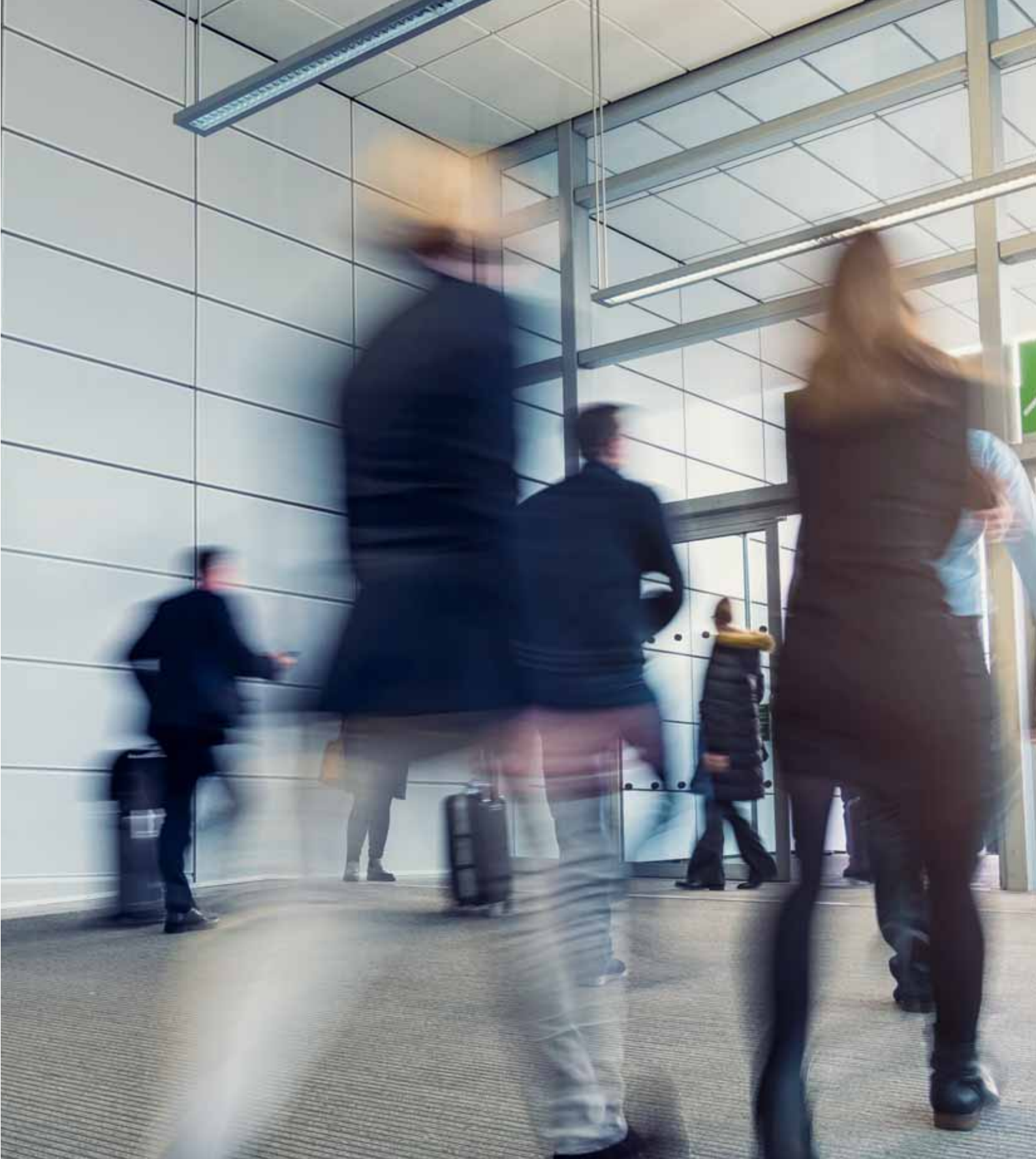



 **FLEXWAY**
DYNAMIC EXIT SIGN



FACTS

- Zinc die-cast housing, white
- IP65
- LCD Display for flexible display of 10 different pictographs
- Wall mounting
- Potential free contact for control of the display
- -5° to +40°C









The Flexway exit sign is an emergency luminaire for wall mounting which is used to control rescue routes dynamically, so that hazards can be avoided. The pictographs shown can be changed by the control information of a sensor. The Flexway luminaire can present 10 different pictographs. The luminaire is part of an emergency lighting system according to EN 50171 and meets the requirements of EN 60598-2-22. It is designed for connection to central battery systems.

Flexible display

The Flexway exit sign provides 10 display options. Two operating states are preselectable via rotary coding switches. The different operating states are activated by the dry contact of a smoke detector or fire alarm system. The Flexway features a power limited and monitored output voltage. It is selectable which pictograph appears on the electronics with applied voltage or missing voltage.



DYNAMIC EXIT SIGN

					
LUMINAIRES FOR CENTRAL BATTERY SYSTEMS AC/DC INCL. MONITORING MODULE					
LCD, 230V AC/DC	FMWD009ML	FMWD009ML-AZ	CPS	5,4 W	

Technical specifications

Operating voltage LCD Panel 12V DC (7V ... 12V DC) SELV
 perm. ambient temperature -5°C - +40°C

LCD
 Arrow directions 8
 Blocking symbol 1
 Others non-maintained mode
 Brightness in white 180cd/m2

Sensor Connection
 Output 3,3V DC 20mA
 Input 3,3V DC
 Connection cross-section 1,5mm2

In case of an emergency

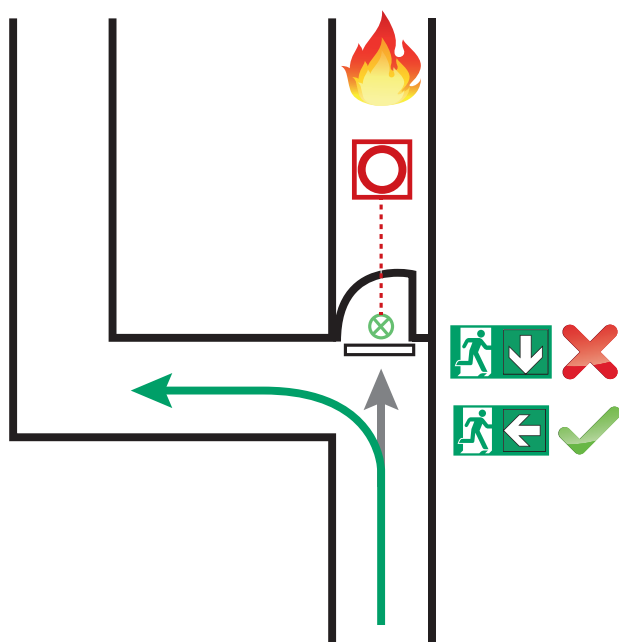

Displayable pictographs

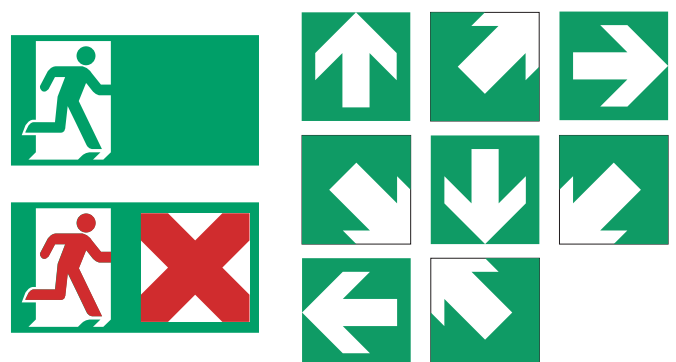



WALL MOUNTING

Dimensions and drilling distances

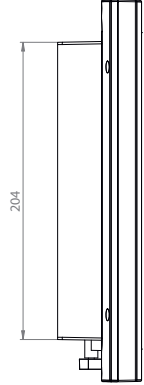
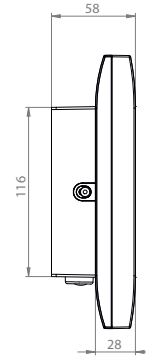
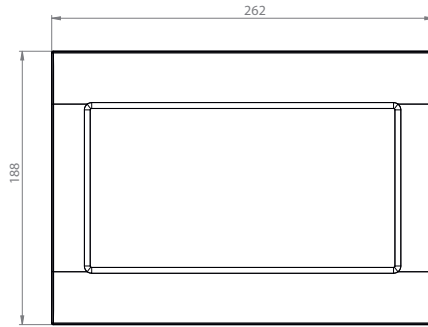
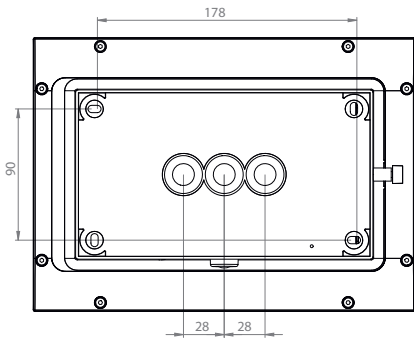

ACCESSORIES

FMDA - ceiling mount adapter

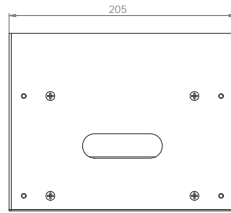
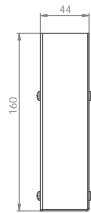
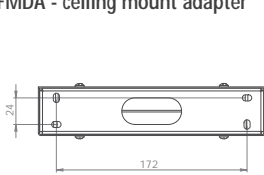

FMDA001 – single side mounting
FMDA001-AZ – anthracite, single side mounting

FMDA002 – double sided mounting
FMDA002 – anthracite, double sided mounting

All Dimensions in mm



 **UNIVERSAL LUMINAIRES**

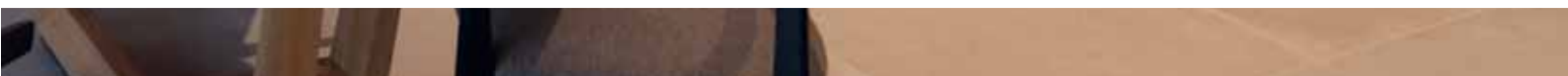



KFMU

UNIVERSAL POLYCARBONATE LUMINAIRE



FACTS

- Polycarbonate housing, white
- Split pictograph set (ISO 7010), splitted pictograph
- IP40
- Universal mounting
- Self-contained: -5° to +40°C
CPS versions: -30° to +40°C



Slim convex escape sign luminaire with a clear, closed cover. The universal installation includes wall and ceiling mounting, as well as the option of ceiling installation in conjunction with the available installation frame.

internal and are inserted without solvents. The pictogram set (arrow right, left, top and bottom) is included in the scope of delivery as standard.

Planning security for marking escape and rescue routes for one- or two-sided labeling is provided by the tool-free, variable use of the pictograms on site. The pictograms are

Escape sign light in accordance with DIN EN 60598-1, DIN EN 60598-2-22 and DIN EN 1838.

LUMINAIRES FOR CENTRAL BATTERY SYSTEMS AC/DC INCL. MONITORING MODULE				
LED, 230V AC/DC	KFMU009ML	CPS	2,3 W	

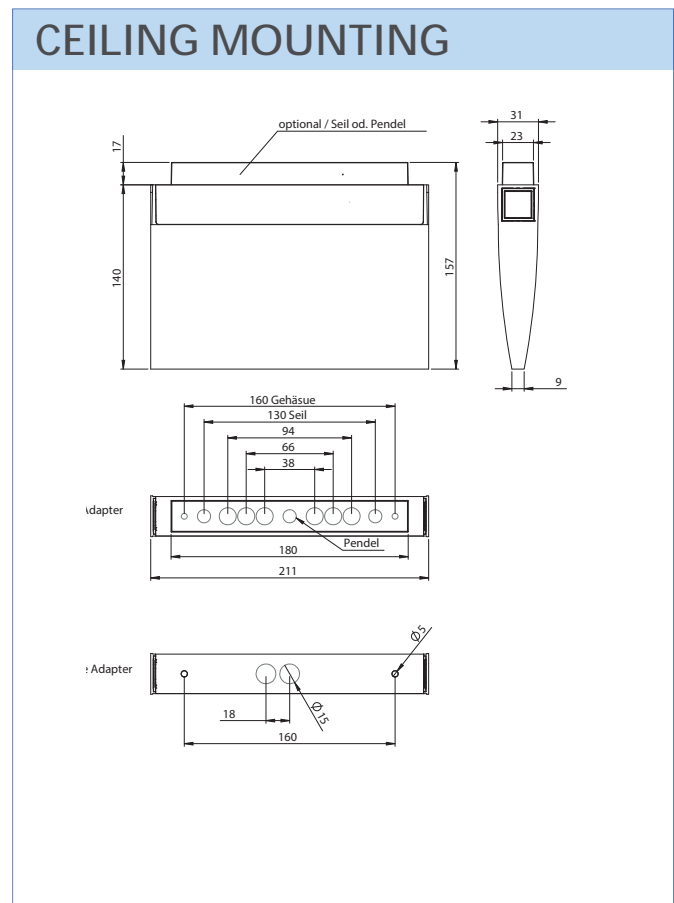
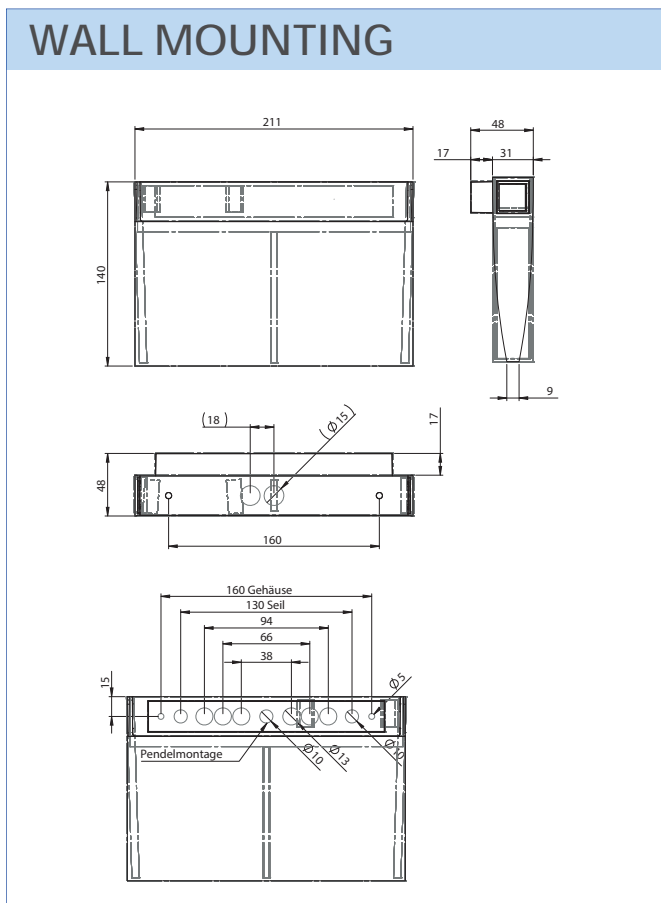

All dimensions in mm



KM / KMUK / KMMU

UNIVERSAL POLYCARBONATE LUMINAIRES

FACTS

- Plastic, white or black
- Complete set of pictographs (ISO 7010)
- IP43
- Universal mounting
- SelfContained: -5° to +40°C
Central battery: -30° to +40°C

Emergency sign luminaire in accordance to DIN EN 60598-1, DIN EN 60598-2-22 and DIN EN 1838.

Slim, elegant, convex, synthetic luminaire tilted towards the viewer, continuously symmetrically tapered towards the bottom. For universal mounting (wall/ceiling surface mount/integrated ceiling mount/brackets). For mounting convenience, the luminaire consists of only 3 parts.

Toolfree mountable on the quick assembly integrated ceiling mounting or wall mounting system. The luminaire has zero potential when dismantled.

Suitable for continuous mode or stand-by mode. Reliable planning due to a toolfree and variable, on-site use of the pictographs. Set of pictographs (left, right, down, up) is included in the scope of delivery.





UNIVERSAL PLASTIC LUMINAIRES

	universal	universal				
SELF-CONTAINED LUMINAIRES WITH SELFCONTROL MODULE						
LED, 1h, 230V AC	KMU411SC	KMU411SC-SW	5 GARANTIE WARRANTY	1 h	4,6 W	3,2V / 1,6Ah LiFePO4
LED, 3h, 230V AC	KMUK403SC	KMUK403SC-SW		3 h	3,7 W	3,2V / 1,5Ah LiFePO4
LED, 3h, 230V AC	KMU413SC	KMU413SC-SW	5 GARANTIE WARRANTY	3 h	4,6 W	3,2V / 1,6Ah LiFePO4
LED, 8h, 230V AC	KMU418SC	KMU418SC-SW	5 GARANTIE WARRANTY	8 h	4,6 W	3,2V / 1,6 Ah LiFePO4
SELF-CONTAINED LUMINAIRES WITH WIRELESS BASIC MODULE						
LED, 1h, 230V AC	KMU411WB	KMU411WB-SW	5 GARANTIE WARRANTY	1 h	5,3 W	3,2V / 1,6 Ah LiFePO4
LED, 3h, 230V AC	KMU413WB	KMU413WB-SW	5 GARANTIE WARRANTY	3 h	5,3 W	3,2V / 1,6 Ah LiFePO4
LED, 8h, 230V AC	KMU418WB	KMU411WB-SW	5 GARANTIE WARRANTY	8 h	5,3 W	3,2V / 1,6 Ah LiFePO4
SELF-CONTAINED LUMINAIRES WITH WIRELESS PROFESSIONAL MODULE (SWITCHABLE)						
LED, 1h, 230V AC	KMU411WL	KMU411WL-SW	5 GARANTIE WARRANTY	1 h	5,3 W	3,2V / 1,6 Ah LiFePO4
LED, 3h, 230V AC	KMU413WL	KMU413WL-SW	5 GARANTIE WARRANTY	3 h	5,3 W	3,2V / 1,6 Ah LiFePO4
LED, 8h, 230V AC	KMU418WL	KMU418WL-SW	5 GARANTIE WARRANTY	8 h	5,3 W	3,2V / 1,6 Ah LiFePO4
LUMINAIRES FOR CORE COMPACT LOW-POWER SYSTEMS 24V AC/DC INCL. MONITORING MODULE						
LED, 24V AC/DC	KMU519CC	KMU519CC-SW		CPS	2,1 W	
LUMINAIRES FOR CENTRAL BATTERY SYSTEMS AC/DC INCL. MONITORING MODULE						
LED, 230V AC/DC	KMU019ML	KMU019ML-SW	5 GARANTIE WARRANTY	CPS	3,2 W	

UNIVERSAL MOUNTING

Dimensions KM / KMUK

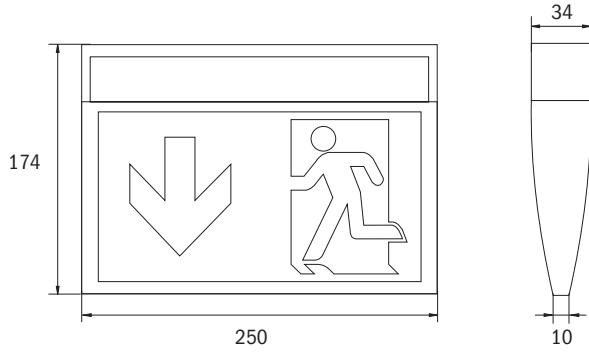

KME recessed mounting frame / cut-out

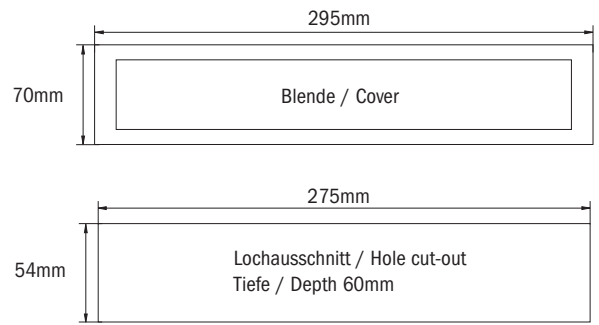

Drilling distances KM ceiling/wall

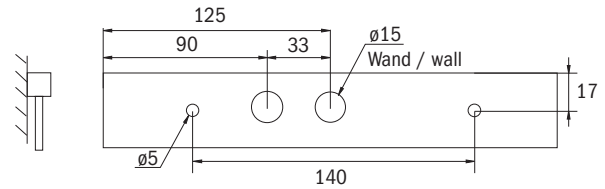
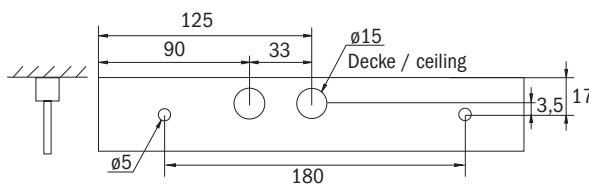

All Dimensions in mm

ACCESSORIES

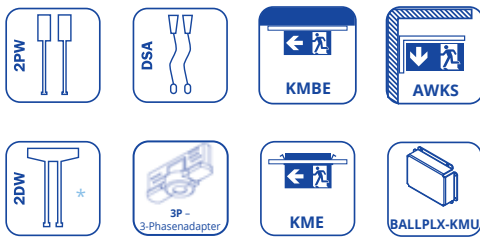

* (not for KMU413)



UNIVERSAL POLYCARBONATE LUMINAIRE WITH CLEAR COVER



	universal					
SELF-CONTAINED LUMINAIRES WITH SELFCONTROL MODULE						
LED, 1h, 230V AC	KMMU411SC		1 h	4,6 W	3,2V / 1,6Ah LiFePO4	
LED, 3h, 230V AC	KMMU413SC		3 h	4,6 W	3,2V / 1,6Ah LiFePO4	
LED, 8h, 230V AC	KMMU418SC		8 h	4,6 W	3,2V / 1,6 Ah LiFePO4	
SELF-CONTAINED LUMINAIRES WITH WIRELESS BASIC MODULE						
LED, 1h, 230V AC	KMMU411WB		1 h	5,3 W	3,2V / 1,6 Ah LiFePO4	
LED, 3h, 230V AC	KMMU413WB		3 h	5,3 W	3,2V / 1,6 Ah LiFePO4	
LED, 8h, 230V AC	KMMU418WB		8 h	5,3 W	3,2V / 1,6 Ah LiFePO4	
SELF-CONTAINED LUMINAIRES WITH WIRELESS PROFESSIONAL MODULE (SWITCHABLE)						
LED, 1h, 230V AC	KMMU411WL		1 h	5,3 W	3,2V / 1,6 Ah LiFePO4	
LED, 3h, 230V AC	KMMU413WL		3 h	5,3 W	3,2V / 1,6 Ah LiFePO4	
LED, 8h, 230V AC	KMMU418WL		8 h	5,3 W	3,2V / 1,6 Ah LiFePO4	
LUMINAIRES FOR CORE COMPACT LOW-POWER SYSTEMS 24V AC/DC INCL. MONITORING MODULE						
LED, 24V AC/DC	KMMU519CC		CPS	2,1 W		
LUMINAIRES FOR CENTRAL BATTERY SYSTEMS AC/DC INCL. MONITORING MODULE						
LED, 230V AC/DC	KMMU019ML		CPS	3,2 W		

UNIVERSAL MOUNTING

Dimensions KMMU

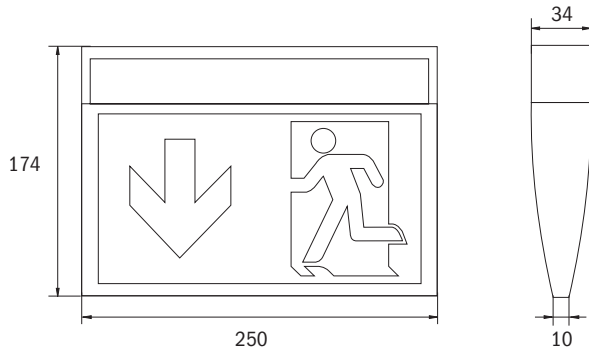

KME recessed mounting frame / cut-out

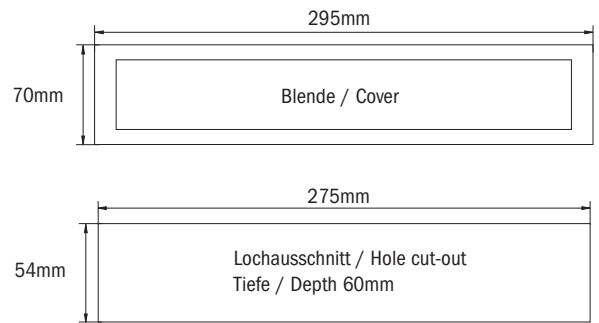

Drilling distances KM ceiling/wall

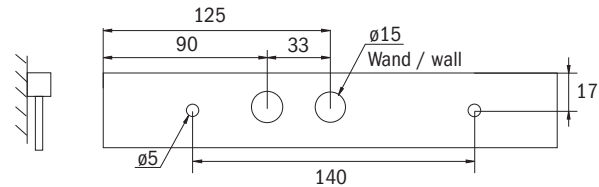
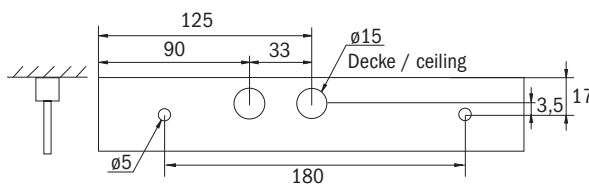

All Dimensions in mm

ACCESSORIES

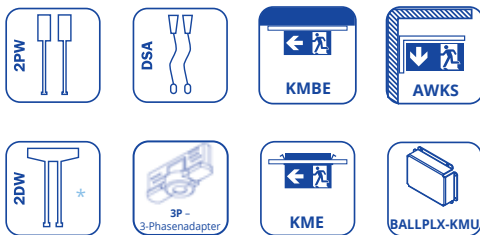

* (not for KM4013)



KSU

UNIVERSAL POLYCARBONATE EDGE LUMINAIRE



FACTS

- Plastic, white
- Complete set of pictographs (ISO 7010)
- IP54
- Universal mounting
- SelfContained: -5° to +40°C
Central battery: -30° to +40°C

Innovative plastic edge LED luminaire for universal mounting . This luminaire has a simple installation using only 3 parts.

Applicable for maintained or non-maintained operation mode. Improved reliability through easy to install universal use of pictograms. Universal pictogram set (left, right, up, down) included.

Exit sign according to EN 60598-1, EN 605982-22 and EN 1838 norms.



KSE-MB

Elegant: optional mounting frame with metal cover



GENERAL INFORMATION

DESIGN LUMINAIRES

DYNAMIC LUMINAIRES

UNIVERSAL LUMINAIRES

INDUSTRIAL LUMINAIRES

GENERAL LIGHTING WITH EMERGENCY LIGHT

WIRELESS MONITORING

ACCESSORIES

MODULES



KSC

UNIVERSAL POLYCARBONATE EDGE LUMINAIRE



GENERAL INFORMATION

FACTS

- Plastic, white
- Complete set of pictographs (ISO 7010)
- IP54
- Universal mounting
- SelfContained: -5° to +40°C
Central battery: -30° to +40°C

Innovative high-grade LED exit sign and emergency luminaire for universal mounting. This luminaire has a simple installation using only 3 parts. Applicable for maintained or non-maintained operation mode. Improved reliability through easy to install and universal use of pictograms. Universal pictogram set (left, right, up, down) included.

The KSC luminaire is also designed for illumination of fire fighting and first aid facilities with at least 5 lux on the equipment according to EN 1838.

Signs according to EN 60598-1, EN 60598-2-22 and EN 1838 norms.



DESIGN LUMINAIRES

DYNAMIC LUMINAIRES



UNIVERSAL LUMINAIRES

INDUSTRIAL LUMINAIRES

GENERAL LIGHTING WITH EMERGENCY LIGHT



WIRELESS MONITORING

ACCESSORIES

MODULES



UNIVERSAL POLYCARBONATE EDGE LUMINAIRE

KSU WITH WHITE COVER

SELF-CONTAINED LUMINAIRES WITH SELFCONTROL MODULE						
LED, 1h, 230V AC	KSU411SC	KSU411SC-SW	1 h	4,6 W	3,2V / 1,6Ah LiFePO4	
LED, 3h, 230V AC	KSU413SC	KSU413SC-SW	3 h	4,6 W	3,2V / 1,6Ah LiFePO4	
LED, 8h, 230V AC	KSU418SC	KSU418SC-SW	8 h	4,6 W	3,2V / 1,6 Ah LiFePO4	
SELF-CONTAINED LUMINAIRES WITH WIRELESS BASIC MODULE						
LED, 1h, 230V AC	KSU411WB	KSU411WB-SW	1 h	5,3 W	3,2V / 1,6 Ah LiFePO4	
LED, 3h, 230V AC	KSU413WB	KSU413WB-SW	3 h	5,3 W	3,2V / 1,6 Ah LiFePO4	
LED, 8h, 230V AC	KSU418WB	KSU418WB-SW	8 h	5,3 W	3,2V / 1,6 Ah LiFePO4	
SELF-CONTAINED LUMINAIRES WITH WIRELESS PROFESSIONAL MODULE (SWITCHABLE)						
LED, 1h, 230V AC	KSU411WL	KSU411WL-SW	1 h	5,3 W	3,2V / 1,6 Ah LiFePO4	
LED, 3h, 230V AC	KSU413WL	KSU413WL-SW	3 h	5,3 W	3,2V / 1,6 Ah LiFePO4	
LED, 8h, 230V AC	KSU418WL	KSU418WL-SW	8 h	5,3 W	3,2V / 1,6 Ah LiFePO4	
LUMINAIRES FOR CORE COMPACT LOW-POWER SYSTEMS 24V AC/DC INCL. MONITORING MODULE						
LED, 24V AC/DC	KSU519CC	KSU519CC-SW	CPS	2,1 W		
LUMINAIRES FOR CENTRAL BATTERY SYSTEMS AC/DC INCL. MONITORING MODULE						
LED, 230V AC/DC	KSU019ML	KSU019ML-SW	CPS	3,2 W		

UNIVERSAL MOUNTING

Drilling distances KSU/KSC ceiling/wall

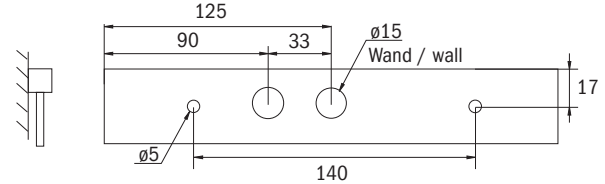
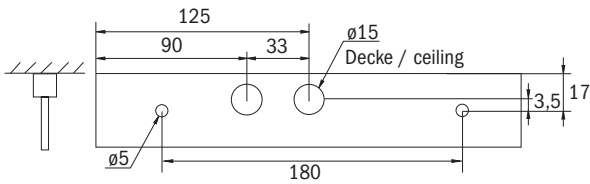

KME / KSE-MB recessed frame



Hole cut-out KME KSE-MB recessed frame



Dimensions KSU/KSC

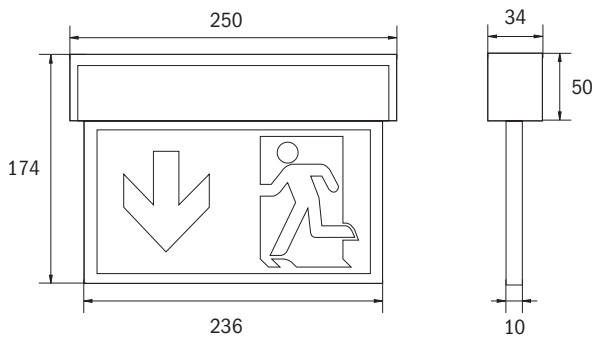

All Dimensions in mm

ACCESSORIES

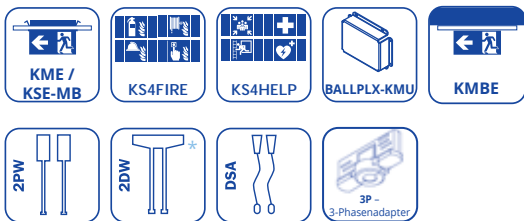

* (not for KSU/KSC413)



UNIVERSAL PLASTIC EDGE LUMINAIRE

KSC WITH CLEAR COVER

SELF-CONTAINED LUMINAIRES WITH SELFCONTROL MODULE						
LED, 1h, 230V AC	KSC411SC	KSC411SC-SW	1 h	4,6 W - 190 lm	3,2V / 1,6 Ah LiFePO4	
LED, 3h, 230V AC	KSC413SC	KSC413SC-SW	3 h	4,6 W - 190 lm	3,2V / 3,3 Ah LiFePO4	
LED, 8h, 230V AC	KSC418SC	KSC418SC-SW	8 h	4,6 W - 85 lm	3,2V / 3,3 Ah LiFePO4	
SELF-CONTAINED LUMINAIRES WITH WIRELESS BASIC MODULE						
LED, 1h, 230V AC	KSC411WB	KSC411WB-SW	1 h	5,3 W - 190 lm	3,2V / 1,6 Ah LiFePO4	
LED, 3h, 230V AC	KSC413WB	KSC413WB-SW	3 h	5,3 W - 190 lm	3,2V / 3,3 Ah LiFePO4	
LED, 8h, 230V AC	KSC418WB	KSC418WB-SW	8 h	5,3 W - 85 lm	3,2V / 3,3 Ah LiFePO4	
SELF-CONTAINED LUMINAIRES WITH WIRELESS PROFESSIONAL MODULE (SWITCHABLE)						
LED, 1h, 230V AC	KSC411WL	KSC411WL-SW	1 h	5,3 W - 190 lm	3,2V / 1,6 Ah LiFePO4	
LED, 3h, 230V AC	KSC413WL	KSC413WL-SW	3 h	5,3 W - 190 lm	3,2V / 3,3 Ah LiFePO4	
LED, 8h, 230V AC	KSC418WL	KSC418WL-SW	8 h	5,3 W - 85 lm	3,2V / 3,3 Ah LiFePO4	
LUMINAIRES FOR CORE COMPACT LOW-POWER SYSTEMS 24V AC/DC INCL. MONITORING MODULE						
LED, 24V AC/DC	KSC519CC	KSC519CC-SW	CPS	2,1 W - 220 lm		
LUMINAIRES FOR CENTRAL BATTERY SYSTEMS AC/DC INCL. MONITORING MODULE						
LED, 230V AC/DC	KSC019ML	KSC019ML-SW	CPS	3,2 W - 220 lm		



Distance table KSC413 for plane emergency routes

Mounting height (m)					
2.00	2.86	7.25	7.12	6.94	2.65
2.50	1.27	7.68	7.64	7.32	2.98
3.00	1.15	6.47	6.16	7.91	2.90
3.50	1.14	3.71	6.05	8.37	2.64
4.00	1.15	3.34	5.69	8.38	2.50

Illumination KSC013 – 1m above the ground, Mounting height of the luminaire 2,20m

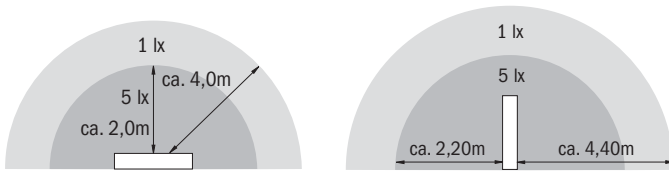

ACCESSORIES

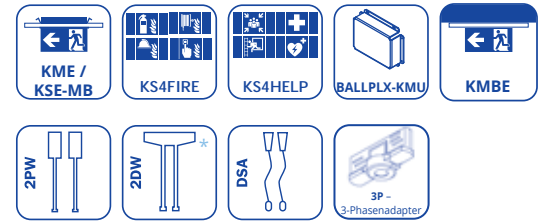

* (not for KSU/KSC413)





KA

UNIVERSAL POLYCARBONATE EDGE LUMINAIRE



FACTS

- Polycarbonate housing, white
- Viewing distance 22 or 30m
- Complete set of pictographs (ISO 7010)
- IP64
- Universal mounting
- Self-contained: -5° to +40°C
CPS versions: -30° to +40°C

Polycarbonate luminaire with a cuboid-shaped housing, discreetly reduced to the essentials. The design and universal mounting are based on the KB light series, with the disc for holding the escape sign being permanently installed.

The luminaires are equipped with modern LED lamps and offer flexibility thanks to interchangeable pictograms.

LED escape sign light in accordance with DIN EN 60598-1, DIN EN 60598-2-22, DIN EN 7010 and DIN EN 1838.



UNIVERSAL POLYCARBONATE EDGE LUMINAIRE

KAM - VIEWING DISTANCE 22M

SELF-CONTAINED LUMINAIRES WITH SELFCONTROL MODULE					
LED, 1h, 230V AC	KAMU401SC	1 h	4,3 W	6,4V/1,2Ah LiFeP04	
LED, 3h, 230V AC	KAMU403SC	3 h	4,3 W	6,4V/1,2Ah LiFeP04	
LED, 8h, 230V AC	KAMU408SC	8 h	4,3 W	6,4V/1,2Ah LiFeP04	
SELF-CONTAINED LUMINAIRES WITH WIRELESS PROFESSIONAL MODULE (SWITCHABLE)					
LED, 1h, 230V AC	KAMU401WL	1 h	4,7 W	6,4V/1,2Ah LiFeP04	
LED, 3h, 230V AC	KAMU403WL	3 h	4,7 W	6,4V/1,2Ah LiFeP04	
LED, 8h, 230V AC	KAMU408WL	8 h	4,7 W	6,4V/1,2Ah LiFeP04	
LUMINAIRES FOR CORE COMPACT LOW-POWER SYSTEMS 24V AC/DC INCL. MONITORING MODULE					
LED, 24V AC/DC	KAMU509CC	CPS	2,6 W		
LUMINAIRES FOR CENTRAL BATTERY SYSTEMS AC/DC					
LED, 230V AC/DC	KAMU009	CPS	2,4 W		
LUMINAIRES FOR CENTRAL BATTERY SYSTEMS AC/DC INCL. MONITORING MODULE					
LED, 230V AC/DC	KAMU009ML	CPS	3,5 W		

UNIVERSAL MOUNTING

Dimensions KAMU

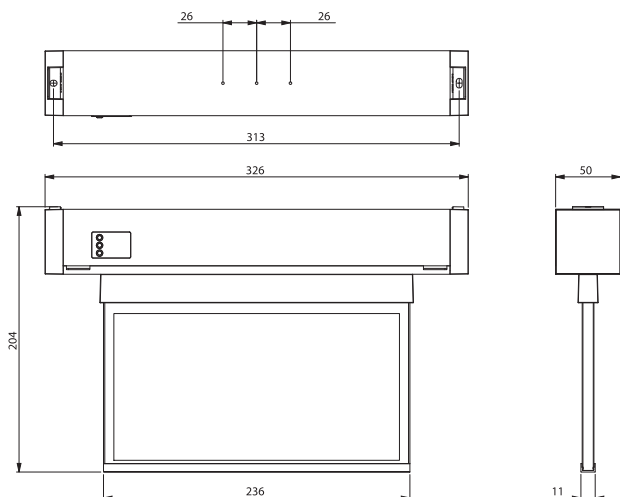



KAX - VIEWING DISTANCE 30M

SELF-CONTAINED LUMINAIRES WITH SELFCONTROL MODULE					
LED, 1h, 230V AC	KAXU401SC	1 h	4,2 W	6,4V/1,2Ah LiFeP04	
LED, 3h, 230V AC	KAXU403SC	3 h	4,2 W	6,4V/1,2Ah LiFeP04	
LED, 8h, 230V AC	KAXU408SC	8 h	4,2 W	6,4V/1,2Ah LiFeP04	
SELF-CONTAINED LUMINAIRES WITH WIRELESS PROFESSIONAL MODULE (SWITCHABLE)					
LED, 1h, 230V AC	KAXU401WL	1 h	5,6 W	6,4V/1,2Ah LiFeP04	
LED, 3h, 230V AC	KAXU403WL	3 h	5,6 W	6,4V/1,2Ah LiFeP04	
LED, 8h, 230V AC	KAXU408WL	8 h	5,6 W	6,4V/1,2Ah LiFeP04	
LUMINAIRES FOR CORE COMPACT LOW-POWER SYSTEMS 24V AC/DC INCL. MONITORING MODULE					
LED, 24V AC/DC	KAXU509CC	CPS	3,7 W		
LUMINAIRES FOR CENTRAL BATTERY SYSTEMS AC/DC					
LED, 230V AC/DC	KAXU009	CPS	3,3 W		
LUMINAIRES FOR CENTRAL BATTERY SYSTEMS AC/DC INCL. MONITORING MODULE					
LED, 230V AC/DC	KAXU009ML	CPS	4,5 W		

UNIVERSAL MOUNTING

Dimensions KAXU

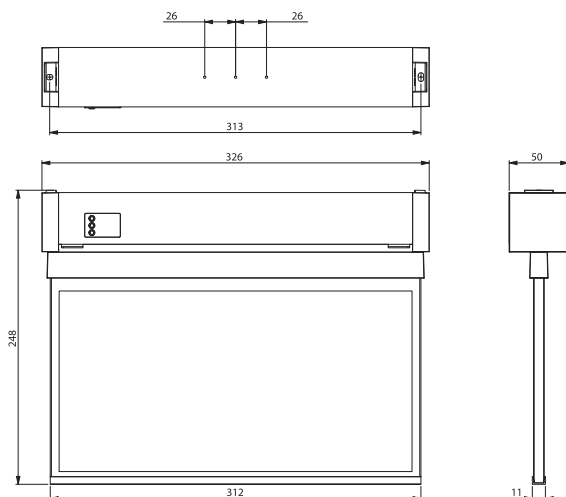



KBU

MODULAR EMERGENCY AND EXIT SIGN LUMINAIRE



FACTS

- Plastic, white
- Emergency luminaire
- Can be converted into an exit sign luminaire with a viewing distance of 14-30m using optional pane sets
- Included with the optional pane set: Complete pictogram set (ISO 7010)
- IP64
- Universal mounting
- Permissible Temperature:
 - 5°C to +40°C;
 - KBU019/KBU029/KBDUO029: -30°C to +40°C *
 - KBU013-COOL: -30°C to +40°C

LED exit sign / emergency light according to DIN EN 60598-1, EN 60598-2-22, EN 7010 and DIN EN 1838. Cuboid plastic housing, discreetly reduced design on the lamps substance. Modular design and universal mounting for use as emergency luminaire with and without the application of pictograms.

The modular system allows the light to be converted at any time without dismantling and tools to a exit sign luminaire. Panes for mounting pictograms have to be ordered separately.

Advantages KB-DUO

Illumination of pictographs in normal operation with normal high power LED. In emergency operation the luminaire switches to the integrated ERT-LED for lighting escape routes as well as the pictograph. The use of special lenses and high performance ERT LED technology ensures a optimal light distribution in the escape and rescue route. This makes large luminaire distances possible.

You get planning safety by variable use and toolless change of pictograms.

Comparison of light distribution KBU / KB-DUO

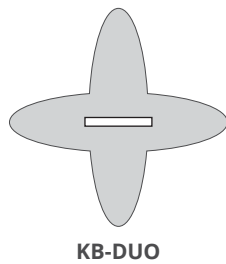
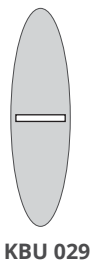

*) The luminaires can be operated with individual luminaire monitoring in mixed mode circuits (1h-preheating time) and in maintained mode circuits or without individual luminaire monitoring in all circuit types.

MODULAR EMERGENCY AND EXIT SIGN LUMINAIRE

						
SELF-CONTAINED LUMINAIRES WITH SELFCONTROL MODULE						
LED, 1h, 230V AC	KBU411SC	KBU411SC-COOLIP54	1 h	5,5 W - 320 lm	6,4V/1,6Ah LiFeP04	
LED, 1h, 230V AC	KBU421SC	KBU421SC-COOLIP54	1 h	6,4 W - 520 lm	6,4V/1,6Ah LiFeP04	
LED, 3h, 230V AC	KBU413SC	KBU413SC-COOLIP54	3 h	4,1 W - 225 lm	6,4V/1,6Ah LiFeP04	
LED, 3h, 230V AC	KBU423SC	KBU423SC-COOLIP54	3 h	4,2 W - lm	6,4V/1,6Ah LiFeP04	
LED, 8h, 230V AC	KBU418SC	KBU418SC-COOLIP54	8 h	6,7 W - 160 lm	6,4V/1,6Ah LiFeP04	
SELF-CONTAINED LUMINAIRES WITH WIRELESS PROFESSIONAL MODULE						
LED, 1h, 230V AC	KBU421WL	KBU421WL-COOLIP54	1 h	7,5 W - 460 lm	6,4V/1,2Ah LiFeP04	
LED, 1h, 230V AC	KBU411WL	KBU411WL-COOLIP54	1 h	5,3 W - lm	6,4V/1,6Ah LiFeP04	
LED, 3h, 230V AC	KBU423WL	KBU423WL-COOLIP54	3 h	W - 210 lm	6,4V/1,2Ah LiFeP04	
LED, 3h, 230V AC	KBU413WL	KBU413WL-COOLIP54	3 h	5,3 W - lm	6,4V/1,6Ah LiFeP04	
LED, 8h, 230V AC	KBU418WL	KBU418WL-COOLIP54	8 h	5,3 W - lm	6,4V/1,6Ah LiFeP04	
LUMINAIRES FOR CORE COMPACT LOW-POWER SYSTEMS 24V AC/DC INCL. MONITORING MODULE						
LED, 24V, AC/DC	KBU529CC		CPS	3,8 W - 520 lm		
LED, 24V, AC/DC	KBU519CC		CPS	3,6 W - 340 lm		
LUMINAIRES FOR CENTRAL BATTERY SYSTEMS AC/DC						
LED, 230V AC/DC	KBU019		CPS	4,5 W - 300 lm		
LED, 230V AC/DC	KBU029		CPS	4,6 W - 520 lm		
LUMINAIRES FOR CENTRAL BATTERY SYSTEMS AC/DC INCL. MONITORING MODULE						
LED, 230V AC/DC	KBU019ML		CPS	5,2 W - 300 lm		
LED, 230V AC/DC	KBU029ML		CPS	5,2 W - 520 lm		
LED, 230V AC/DC	KBDU0029ML		CPS	5,9 W - 520 lm		

*) All versions also available as COOL-luminaires with external battery housing in IP 54 for mounting within the building. The luminaire may be mounted outside or in cool stores.

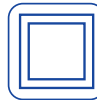

Distance table KBDOU 029ML in Ceilingmontage for plane emergency routes

Mounting height (m)					
2.00	6.97	16.50	14.69	8.24	3.33
2.50	8.18	18.99	16.85	9.00	3.57
3.00	9.23	21.29	18.76	9.68	3.70
3.50	9.62	23.41	20.49	10.26	3.75
4.00	10.42	25.35	22.07	10.50	3.73

The distance table is based on the following parameters: Maintenance factor: 0.8; emergency lighting factor 1.00; Minimum illumination on the center line: 1.00 lux; Minimum illumination on the half width of the rescue

route: 0.50 lux, uniformity on the midline maximum 40:1; Width of the rescue route 2.00m

UNIVERSAL MOUNTING

Dimensions KBU ceiling

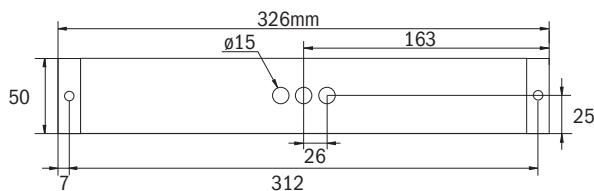

Dimensions KBU wall

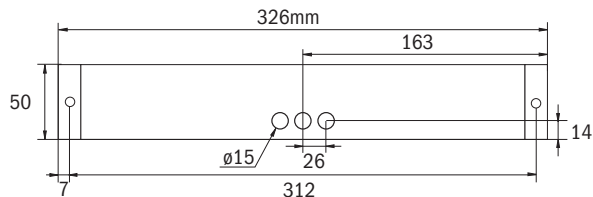

Cut-out for KB recessed frame

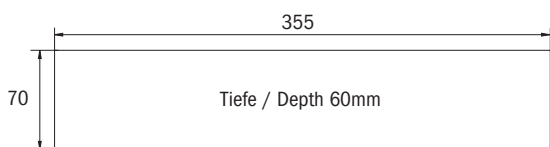

External battery housing -COOLIP54

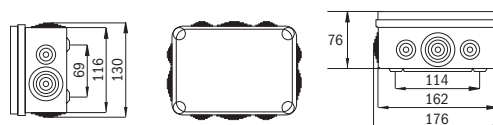

All Dimensions in mm

ACCESSORIES



14m 22m 30m

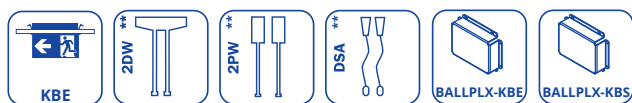

** When mounting with cord suspension or pendulum IP40



*Flexi
Click*

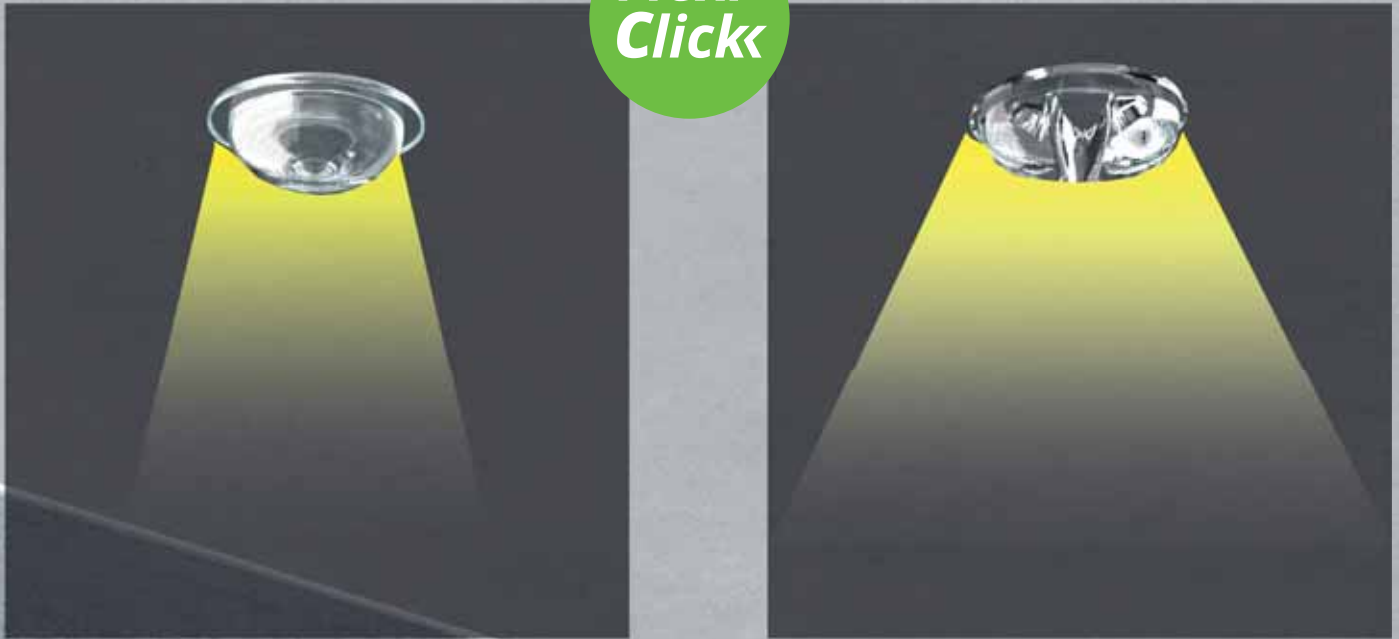

 **IL**
EMERGENCY ROUTE LIGHTING



GENERAL INFORMATION

FACTS

- Plastic, white or black
- Ceiling or recessed mounting
- -5°C to +40°C;
- For IL Dx029: -20° to +30° C in IL-IP65 housing
- IL: IP40; ILE: IP20
- For self-contained luminaires test switch is integrated in LED
- As luminaire for central battery systems with dimming function for reduced blinding effect
- Pluggable corridor or round lens for full flexibility at the installation site

The IL LED safety luminaire in a discreet design is a true all-rounder. Whether as a self-contained light or for connection to central battery systems: it is equipped for almost all requirements and always offers the right solution. Six different lenses for different light distribution are available and enable perfect adaptation to the respective installation situation. All versions of the IL are available for ceiling surface and recessed installation.

The IL surface-mounted luminaire consists of only 2 parts, with the ceiling-mounted body containing the power connection terminals. The actual lamp is installed without tools and is disconnected from the mains voltage when dismantled.

The status LED integrated into the lens does not interrupt the harmony of the discreet housing.

The innovative integrated lens carrier with quick assembly device enables the flexible use of different types of lenses depending on the application. Round and corridor lenses are already included in the scope of delivery of every light.



DESIGN LUMINAIRES

DYNAMIC LUMINAIRES



UNIVERSAL LUMINAIRES

INDUSTRIAL LUMINAIRES

GENERAL LIGHTING WITH EMERGENCY LIGHT



WIRELESS MONITORING

ACCESSORIES

MODULES

EMERGENCY ROUTE LIGHTING

SELF-CONTAINED LUMINAIRES WITH SELFCONTROL MODULE							
System lens (radial/corridor)	ILD421SC	ILD421SC-SW	I421SC	1 h	3 W - 250 lm	3,2V / 3,3 Ah LiFePO ₄	
System lens (radial/corridor)	ILD423SC	ILD423SC-SW	I423SC	3 h	3 W - 250 lm	3,2V / 3,3 Ah LiFePO ₄	
System lens (radial/corridor)	ILD428SC	ILD428SC-SW	I428SC	8 h	3 W - 125 lm	3,2V / 3,3 Ah LiFePO ₄	
SELF-CONTAINED LUMINAIRES WITH WIRELESS BASIC MODULE							
System lens (radial/corridor)	ILD421WB	ILD421WB-SW	I421WB	1 h	3,4 W - 250 lm	3,2V / 3,3 Ah LiFePO ₄	
System lens (radial/corridor)	ILD423WB	ILD423WB-SW	I423WB	3 h	3,4 W - 250 lm	3,2V / 3,3 Ah LiFePO ₄	
System lens (radial/corridor)	ILD428WB	ILD428WB-SW	I428WB	8 h	3,4 W - 125 lm	3,2V / 3,3 Ah LiFePO ₄	
SELF-CONTAINED LUMINAIRES WITH WIRELESS PROFESSIONAL MODULE (SWITCHABLE)							
System lens (radial/corridor)	ILD421WL	ILD421WL-SW	I421WL	1 h	3,4 W - 250 lm	3,2V / 3,3 Ah LiFePO ₄	
System lens (radial/corridor)	ILD423WL	ILD423WL-SW	I423WL	3 h	3,4 W - 250 lm	3,2V / 3,3 Ah LiFePO ₄	
System lens (radial/corridor)	ILD428WL	ILD428WL-SW	I428WL	8 h	3,4 W - 125 lm	3,2V / 3,3 Ah LiFePO ₄	
LUMINAIRES FOR CORE COMPACT LOW-POWER SYSTEMS 24V AC/DC INCL. MONITORING MODULE							
System lens (radial/corridor)	ILD529CC	ILD529CC-SW	I529CC	CPS	2,8 W - 360 lm		
LUMINAIRES FOR CENTRAL BATTERY SYSTEMS AC/DC INCL. MONITORING MODULE							
System lens	ILD029ML	ILD029ML-SW	I029ML	CPS	4,6 W - 360 lm		

CEILING MOUNTING / RECESSED CEILING MOUNTING

Dimensions and cut-out ILE (self-contained and central battery systems)

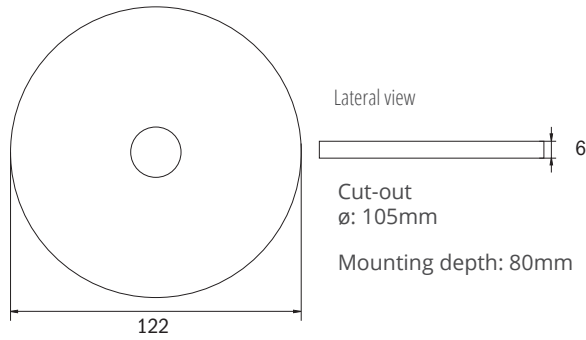

Dimensions and drilling distances (self-contained and central battery systems)

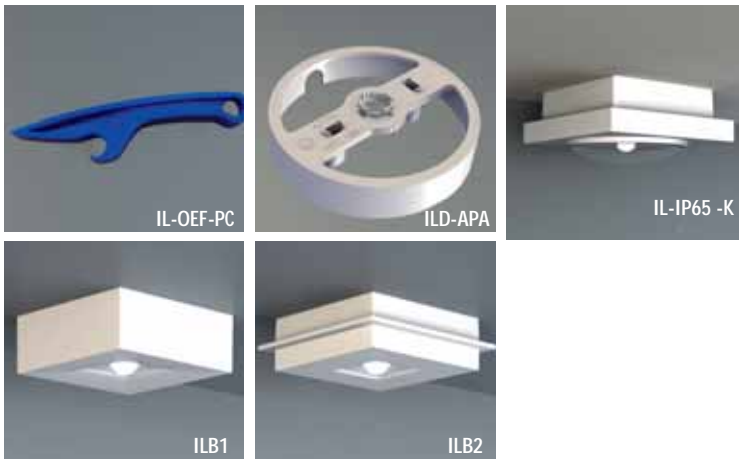
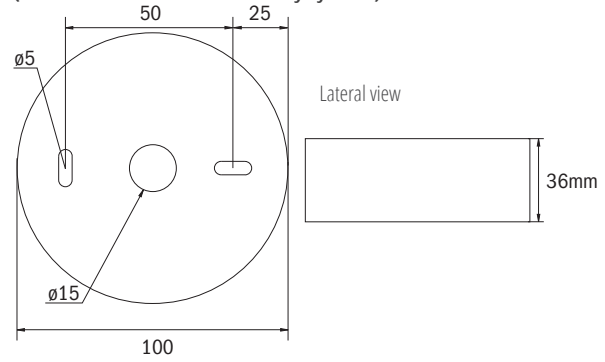

IL-IK10
Surface mounted die-cast housing for all ILD luminaires featuring IK 10 impact protection.



ACCESSORIES



IL-OEF: For easy opening of ILEx an optional opener is available.



ILD-APA: white Adapter plate for lateral cable feed to ILD-luminaires



IL-IP65-K: IP65 housing for IL ceiling luminaire (polycarbonate, white or anthrazite, chlorine resistant)



LSYS-S: Spotlens for luminaires with lens system. Suitable for ceilings up to 12m.



LSYS-B: Beam lens for luminaires with lens system. To illuminate firefighting and help points on the wall.



LSYS-H: Lens for illuminating corridors with ceiling heights > 4m (4 pieces).



ILB1/ILB2: Square covers



BALLPLX-ILD: Acrylic glass ball protection for ILD luminaires



BALLPLX-ILE: Acrylic glass ball protection for ILD luminaires



LSYS-WF: Lens for wall-mounted lights for illuminating corridors (4 pcs.)

EMERGENCY ROUTE LIGHTING





Distance table ILDL029ML / ILEL029ML with corridor lens for plane emergency routes (additional distance tables on our website)

Mounting height (m)					
2.50	2.48	6.64	14.31	22.00	9.61
3.00	2.49	6.88	15.72	24.82	10.17
3.50	2.44	7.02	16.49	27.03	10.52
4.00	2.29	7.07	17.01	28.31	9.63
4.50	2.10	7.02	16.23	29.25	9.21





Distance table ILDL029ML / ILEL029ML with spot lens for plane emergency routes (additional distance tables on our website)

Mounting height (m)					
2.00	2.30	5.44	5.43	5.43	2.30
2.50	2.88	6.80	6.78	6.79	2.88
3.00	3.11	7.75	7.73	7.71	3.11
3.50	3.38	8.26	8.24	8.21	3.26
4.00	3.60	8.80	8.76	8.72	3.48
5.00	3.90	9.70	9.64	9.60	3.90
6.00	4.20	10.50	10.44	10.36	4.04
7.00	4.38	11.22	11.14	11.04	4.20
8.00	4.44	11.82	11.70	11.56	4.26
9.00	4.38	12.27	12.15	12.00	4.38
10.50	4.23	12.81	12.63	12.42	4.02
12.00	3.66	12.99	12.78	12.57	3.66

Distance table ILDL029ML / ILEL029ML with lens for high ceilings for plane emergency routes (additional distance tables on our website)

Mounting height (m)					
2.00	0.39	1.16	5.55	10.06	4.29
2.50	0.49	1.45	6.93	12.58	5.36
3.00	0.58	1.74	8.32	15.10	6.43
3.50	0.68	2.03	9.70	17.61	7.51
4.00	0.78	2.32	11.09	20.13	8.58
5.00	0.80	2.18	12.24	22.88	9.40
6.00	0.84	2.24	12.96	25.08	9.98
7.00	0.98	2.40	13.66	26.82	10.78
8.00	0.98	2.60	14.16	28.46	11.02
9.00	1.11	2.76	14.55	29.88	11.52
10.50	1.11	2.85	15.03	31.53	12.09
12.00	1.26	3.09	15.54	32.73	12.42

Distance table ILDL029 with round lens for plane emergency routes (additional distance tables on our website)

Mounting height (m)					
2.50	4.96	10.58	10.58	10.58	4.96
3.00	5.72	12.26	12.26	12.26	5.72
3.50	6.33	13.91	13.91	13.91	6.33
4.00	6.73	15.46	15.46	15.46	6.73
4.50	6.09	16.81	16.81	16.81	6.09

The distance table is based on the following parameters: Maintenance factor: 0.8; emergency lighting factor 1.00; Minimum illumination on the center line: 1.00 lux; Minimum illumination on the half width of the rescue

route: 0.50 lux, uniformity on the midline maximum 40:1; Width of the rescue route 2.00m

EMERGENCY ROUTE LIGHTING

Distance table ILDL421SC(WB/WL) / ILEL421SC(WB/WL) and ILDL423SC(WB/WL) / ILEL423SC(WB/WL) with corridor lens for plane emergency routes (additional distance tables on our website)

Mounting height (m)					
2.00	2.49	6.66	11.01	15.37	6.77
2.50	2.53	6.90	12.32	17.69	7.81
3.00	2.50	7.10	13.55	19.91	8.64
3.50	2.50	7.18	14.57	21.97	9.34
4.00	2.46	7.14	15.36	23.70	9.94





Distance table ILDL421SC(WB/WL) / ILEL421SC(WB/WL) and ILDL423SC(WB/WL) / ILEL423SC(WB/WL) with spot lens for plane emergency routes (additional distance tables on our website)

Mounting height (m)					
2.00	1.77	3.97	3.97	3.97	1.77
3.00	2.46	5.60	5.60	5.60	2.46
4.00	2.97	6.67	6.67	6.67	2.97
5.00	3.37	7.79	7.79	7.79	3.37
6.00	3.73	8.68	8.68	8.68	3.73
7.00	3.97	9.49	9.49	9.49	3.97
8.00	4.09	10.24	10.24	10.24	4.09
9.00	4.11	10.83	10.83	10.83	4.11
10.00	4.04	11.26	11.26	11.26	4.04
11.00	3.87	11.53	11.53	11.53	3.87
12.00	3.59	11.65	11.65	11.65	3.59





Distance table ILDL421SC(WB/WL) / ILEL421SC(WB/WL) and ILDL423SC(WB/WL) / ILEL423SC(WB/WL) with radial lens for plane emergency routes (additional distance tables on our website)

Mounting height (m)					
2.00	3.98	8.50	8.50	8.50	3.98
2.50	4.74	10.18	10.18	10.18	4.74
3.00	5.31	11.81	11.81	11.81	5.31
3.50	5.44	13.31	13.31	13.31	5.44
4.00	1.52	11.19	11.19	11.19	1.52

Distance table ILDL428SC(WB/WL) / ILEL428SC(WB/WL) with corridor lens for plane emergency routes (additional distance tables on our website)

Mounting height (m)					
2.00	1.70	4.79	9.11	13.35	5.80
2.50	1.68	4.86	10.09	15.37	6.48
3.00	1.63	4.79	10.80	16.94	6.92
3.50	0.00	4.77	7.41	15.01	1.25
4.00	0.00	3.23	4.12	12.58	0.00

Distance table ILDL428SC(WB/WL) / ILEL428SC(WB/WL) with spot lens for plane emergency routes (additional distance tables on our website)

Mounting height (m)					
2.00	1.64	3.75	3.75	3.75	1.64
3.00	2.12	4.86	4.86	4.86	2.12
4.00	2.50	5.82	5.82	5.82	2.50
5.00	2.73	6.63	6.63	6.63	2.73
6.00	2.78	7.28	7.28	7.28	2.78
7.00	2.70	7.70	7.70	7.70	2.70
8.00	2.47	7.88	7.88	7.88	2.47
9.00	2.05	7.85	7.85	7.85	2.05
10.00	1.22	7.62	7.62	7.62	1.22
11.00	0.00	7.18	7.18	7.18	0.00

The distance table is based on the following parameters: Maintenance factor: 0.8; emergency lighting factor 1.00; Minimum illumination on the center line: 1.00 lux; Minimum illumination on the half width of the rescue

route: 0.50 lux, uniformity on the midline maximum 40:1; Width of the rescue route 2.00m



*Flexi
Click*



IADL

EMERGENCY ROUTE LIGHTING



FACTS

- Zinc Die-cast, white
- Ceiling mounting
- -5°C to +40°C;
- IP40
- Pluggable lenses for full flexibility at the installation site

The compact IADL LED safety luminaire made of die-cast zinc is designed for connection to CC24 central battery systems.

Round and floor lenses are included with every light and enable perfect adaptation to the respective installation situation.

The innovative integrated lens carrier with quick-mounting mechanism enables the flexible use of different lens types depending on the application.

LUMINAIRES FOR CORE COMPACT LOW-POWER SYSTEMS 24V AC/DC INCL. MONITORING MODULE				
LED, 24V AC/DC	IADL529CC	CPS	1,5 W - 140 lm	

CEILING MOUNTING

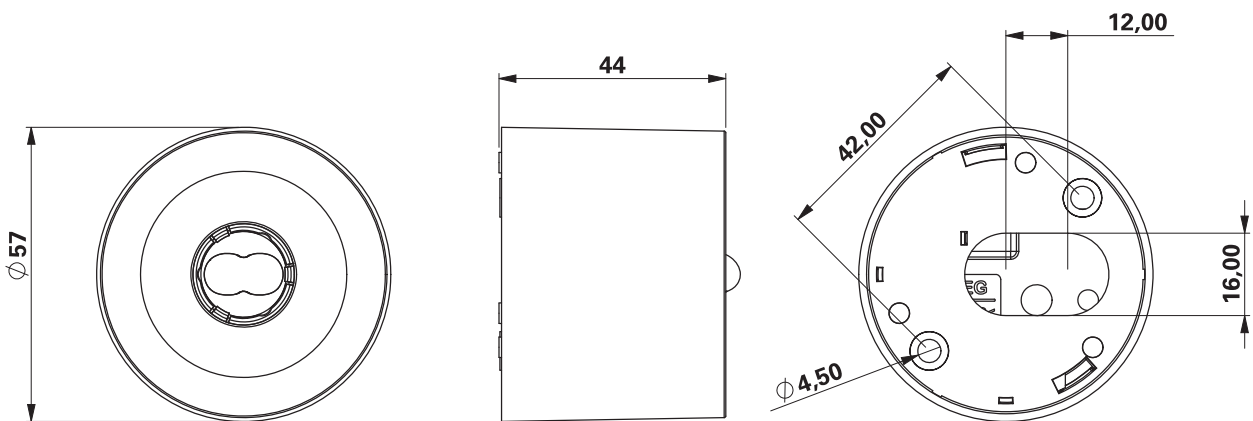

All Dimensions in mm

ACCESSORIES



LSYS-S: Spotlens for luminaires with lens system. Suitable for ceilings up to 12m.



LSYS-H: Lens for illuminating corridors with ceiling heights > 4m (4 pieces).



LSYS-B: Beam lens for luminaires with lens system. To illuminate firefighting and help points on the wall.



LSYS-WF: Lens for wall-mounted lights for illuminating corridors (4 pcs.)



 **KMB**
EMERGENCY ROUTE LIGHTING



GENERAL INFORMATION

FACTS

- Plastic, white
- Universal mounting
- IP54
- SelfContained: -5° to +40°C
Central battery: -30° to +40°C

Compact emergency luminaire for illumination of escape routes with prismatic cover for optimized light distribution. Available as luminaire for central battery systems or as a selfcontained luminaire.

The optional recessed mounting frame hides the luminaire elegantly within the ceiling.



DESIGN LUMINAIRES



DYNAMIC LUMINAIRES

UNIVERSAL LUMINAIRES

INDUSTRIAL LUMINAIRES

GENERAL LIGHTING WITH EMERGENCY LIGHT

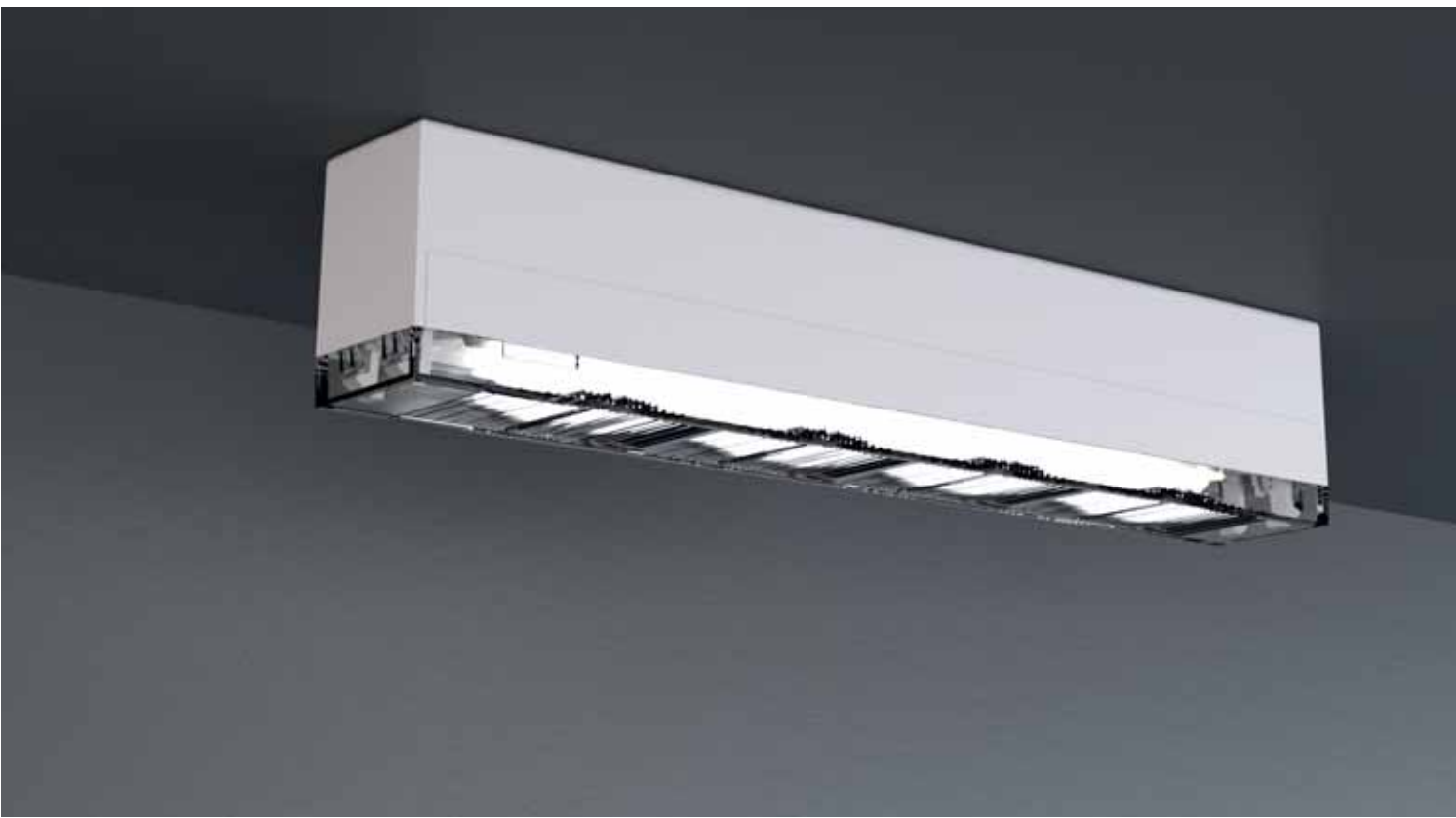

WIRELESS MONITORING

ACCESSORIES

MODULES





EMERGENCY ROUTE LIGHTING

SELF-CONTAINED LUMINAIRES WITH SELFCONTROL MODULE						
LED, 1h, 230V AC	KMB411SC	KMB411SC-SW	1 h		4,6 W - 190 lm	3,2V / 1,6 Ah LiFePO4
LED, 3h, 230V AC	KMB413SC	KMB413SC-SW	3 h		4,6 W - 190 lm	3,2V / 3,3 Ah LiFePO4
LED, 8h, 230V AC	KMB418SC	KMB418SC-SW	8 h		4,6 W - 85 lm	3,2V / 3,3 Ah LiFePO4
SELF-CONTAINED LUMINAIRES WITH WIRELESS BASIC MODULE						
LED, 1h, 230V AC	KMB411WB	KMB411WB-SW	1 h		5,3 W - 190 lm	3,2V / 1,6 Ah LiFePO4
LED, 3h, 230V AC	KMB413WB	KMB413WB-SW	3 h		5,3 W - 190 lm	3,2V / 3,3 Ah LiFePO4
LED, 8h, 230V AC	KMB418WB	KMB418WB-SW	8 h		5,3 W - 85 lm	3,2V / 3,3 Ah LiFePO4
SELF-CONTAINED LUMINAIRES WITH WIRELESS PROFESSIONAL MODULE (SWITCHABLE)						
LED, 1h, 230V AC	KMB411WL	KMB411WL-SW	1 h		5,3 W - 190 lm	3,2V / 1,6 Ah LiFePO4
LED, 3h, 230V AC	KMB413WL	KMB413WL-SW	3 h		5,3 W - 190 lm	3,2V / 3,3 Ah LiFePO4
LED, 8h, 230V AC	KMB418WL	KMB418WL-SW	8 h		5,3 W - 85 lm	3,2V / 3,3 Ah LiFePO4
LUMINAIRES FOR CORE COMPACT LOW-POWER SYSTEMS 24V AC/DC INCL. MONITORING MODULE						
LED, 24V AC/DC	KMB519CC	KMB519CC-SW	CPS		2,1 W - 220 lm	
LUMINAIRES FOR CENTRAL BATTERY SYSTEMS AC/DC INCL. MONITORING MODULE						
LED, 230V AC/DC	KMB019ML	KMB019ML-SW	CPS		3,2 W - 220 lm	



KMB in KME

Distance table KMB019ML for plane emergency routes

Mounting height (m)					
2.00	1.74	4.59	7.81	11.12	4.71
2.50	1.62	4.97	8.71	12.56	5.13
3.00	1.66	4.96	9.40	13.82	5.64
3.50	1.63	4.75	9.79	14.95	6.06
4.00	1.62	4.85	10.32	15.98	6.40

The distance table is based on the following parameters: Maintenance factor: 0.8; emergency lighting factor 1.00; Minimum illumination on the center line: 1.00 lux; Minimum illumination on the half width of the rescue

route: 0.50 lux, uniformity on the midline maximum 40:1; Width of the rescue route 2.00m

UNIVERSAL MOUNTING

Drilling distances KMB ceiling/wall

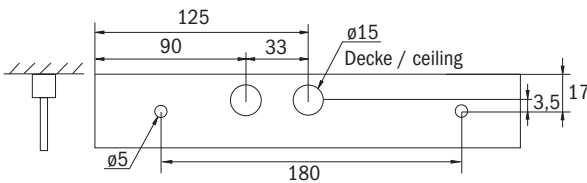

Dimensions KMB

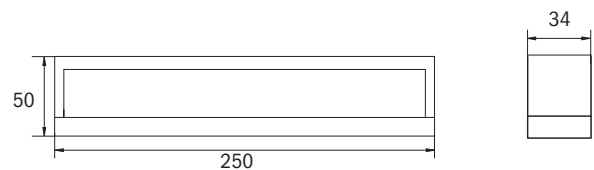

Dimensions KME recessed frame

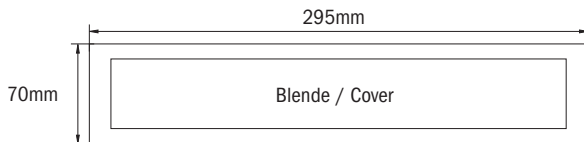

Cut-out KME recessed frame



All Dimensions in mm

ACCESSORIES

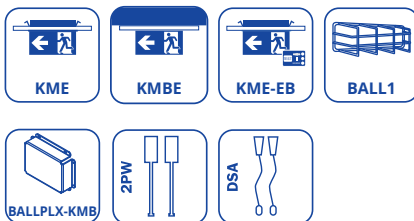

KME Einbaurahmen

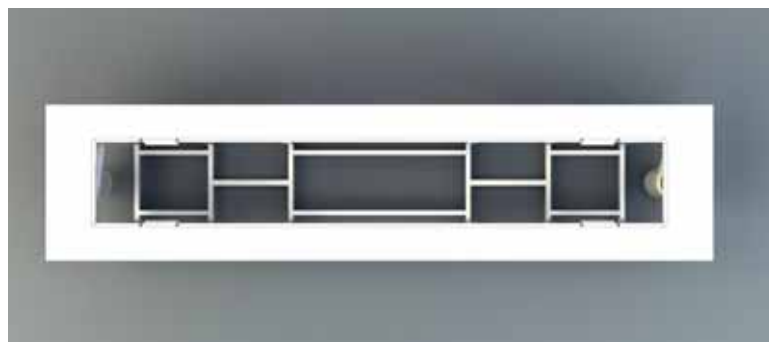



 **DO**
EMERGENCY ROUTE LIGHTING



GENERAL INFORMATION

FACTS

- Plastic, transparent
- Optional for application in third party luminaires
- IP20
- SelfContained: -5° to +40°C
Central battery: -20° to +40°C

Compact Emergency lighting unit with oval lighting ERT-LED luminaire for the lighting of escape and rescue routes according to DIN EN 60598-1, DIN EN 60598-2-22 and EN 1838. For recessed mounting or snap-on mounting on T5/T8 illuminants and metal objects.

Transparent body material makes the luminaire a perfect match in any setting. Available with electronics box or as bulk version for application in existing luminaire cases. Dowel and clips included.



DESIGN LUMINAIRES

DYNAMIC LUMINAIRES

UNIVERSAL LUMINAIRES

INDUSTRIAL LUMINAIRES

GENERAL LIGHTING WITH EMERGENCY LIGHT

WIRELESS MONITORING

ACCESSORIES

MODULES

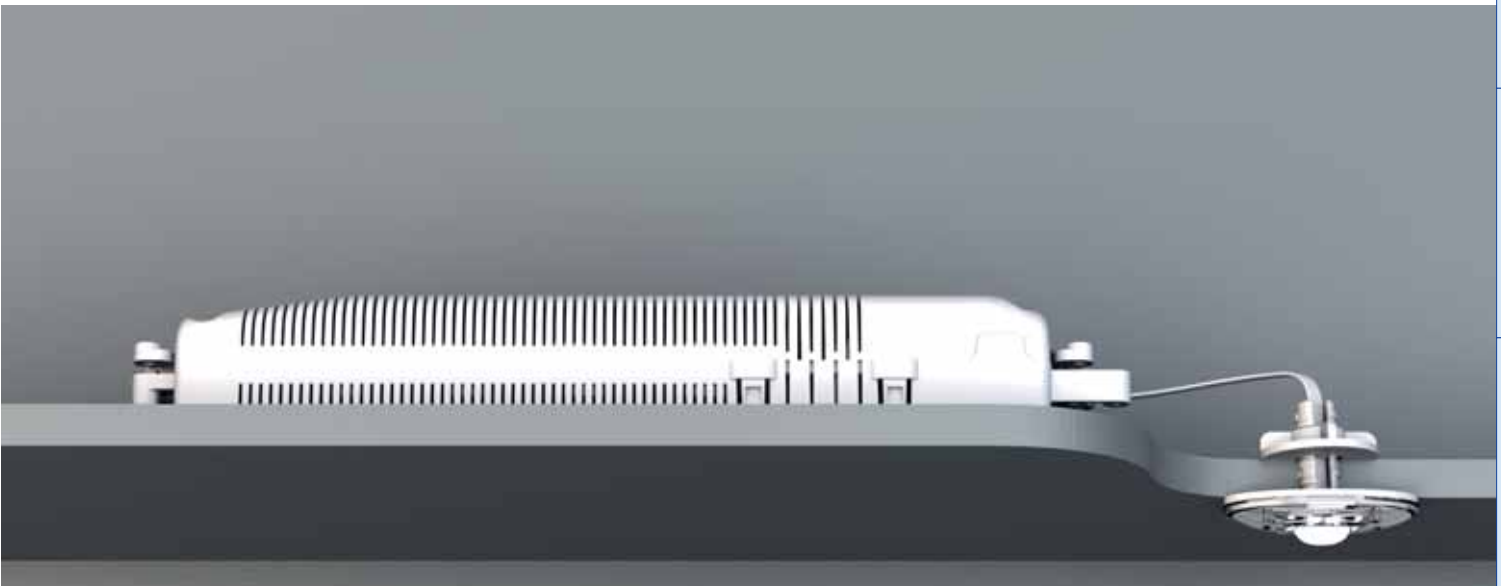





DO incl. electronics box

EMERGENCY ROUTE LIGHTING

	bulk, for mounting in existing luminaires	incl. housing				
SELF-CONTAINED LUMINAIRES WITH SELFCONTROL MODULE						
LED, 1h, 230V AC	DOS021SC	DOE021SC	1 h	3 W - 140 lm	4,8V/2,0Ah NiMH	
LED, 3h, 230V AC	DOS023SC	DOE023SC	3 h	3 W - 140 lm	4,8V/2,0Ah NiMH	
LED, 8h, 230V AC	DOS028SC	DOE028SC	8 h	4,4 W - 140 lm	9,6V/2,0Ah NiMH	
SELF-CONTAINED LUMINAIRES WITH WIRELESS PROFESSIONAL MODULE (SWITCHABLE)						
LED, 1h, 230V AC	DOS021WL	DOE021WL	1 h	5,6 W - 140 lm	4,8V/2,0Ah NiMH	
LED, 3h, 230V AC	DOS023WL	DOE023WL	3 h	5,6 W - 140 lm	4,8V/2,0Ah NiMH	
LUMINAIRES FOR CENTRAL BATTERY SYSTEMS AC/DC						
LED, 230V AC/DC	DOS029	DOE029	CPS	1,9 W - 140 lm		
LUMINAIRES FOR CENTRAL BATTERY SYSTEMS AC/DC INCL. MONITORING MODULE						
LED, 230V AC/DC	DOS029ML	DOE029ML	CPS	2,8 W - 140 lm		

Distance table DO 023 / DO 029 ERT-LED for plane emergency routes

Mounting height (m)					
2.00	1.51	3.74	7.22	10.83	4.71
2.50	1.62	4.16	8.30	12.62	5.36
3.00	1.73	4.49	9.14	14.14	5.64
3.50	1.71	4.74	9.65	15.34	5.60
4.00	1.54	4.89	9.32	16.14	4.44

The distance table is based on the following parameters: Maintenance factor: 0.8; emergency lighting factor 1.00; Minimum illumination on the center line: 1.00 lux; Minimum illumination on the half width of the rescue

route: 0.50 lux, uniformity on the midline maximum 40:1; Width of the rescue route 2.00m

CEILING MOUNTING

Dimensions DOE023 / 029

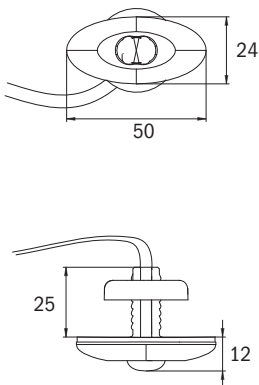

Electronics box

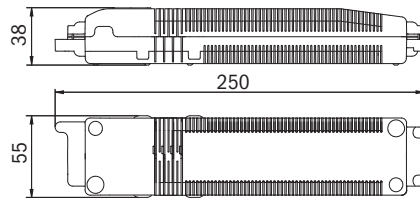

Cut-out electronics box

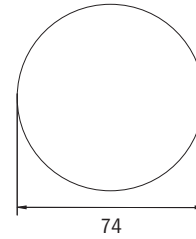

Cut-out DO



All Dimensions in mm

For concrete installation we recommend the HaloX-0 + HaloX-40 boxes from Kaiser.



INDUSTRIAL LUMINAIRES





*Flexi
Click*



 **PM**
POLYCARBONATE LUMINAIRE



FACTS

- Polycarbonate, white
- 20m viewing distance
- Complete set of pictographs (ISO 7010)
- IP65; Insulation class II
- Wall or ceiling mounting
- Self-contained: -5° to +40°C
Central battery: -20° to +40°C



The smaller version of the well-proven KCW light can be used as an escape sign light or as an emergency light and, thanks to its low installation height, is particularly suitable for use in underground car parks.

The mounting tray can be used with both a flat and a high hood.

SELF-CONTAINED LUMINAIRES WITH SELFCONTROL MODULE						
LED, 1h, 230V AC	PMW401SC	PMD401SC	1 h		4,2 W	6,4V/1,6Ah LiFePO4
LED, 3h, 230V AC	PMW403SC	PMD403SC	3 h		4,2 W	6,4V/1,6Ah LiFePO4
LED, 8h, 230V AC	PMW408SC	PMD408SC	8 h		4,2 W	6,4V/3,3Ah LiFePO4
LED, 1h, 230V AC	PMW421SC		1 h		6,4 W - 520 lm	6,4V/1,6Ah LiFePO4
LED, 3h, 230V AC	PMW423SC		3 h		5,4 W - 500 lm	6,4V/3,3Ah LiFePO4
SELF-CONTAINED LUMINAIRES WITH WIRELESS PROFESSIONAL MODULE (SWITCHABLE)						
LED, 1h, 230V AC		PMD421WL	1 h		7,5 W - 460 lm	6,4V/1,2Ah LiFePO4
LED, 1h, 230V AC	PMD401WL	PMD401WL	1 h		3,8 W	3,2V / 0,57Ah LiFePO4
LED, 3h, 230V AC		PMD423WL	3 h		7,5 W - 520 lm	6,4V/3,3Ah LiFePO4
LED, 3h, 230V AC	PMW403WL	PMD403WL	3 h		3,8 W	6,4V/1,2Ah LiFePO4
LED, 8h, 230V AC		PMD428WL	8 h		7,5 W - 245 lm	6,4V/3,3Ah LiFePO4
LUMINAIRES FOR CENTRAL BATTERY SYSTEMS AC/DC INCL. MONITORING MODULE						
LED, 230V AC/DC	PMW009ML	PMD009ML	CPS		3,6 W	
LED, 230V AC/DC	PMW029ML		CPS		5,2 W - 520 lm	
LED, 230V AC/DC	PMW039ML		CPS		9,4 W - 1050 lm	



All self-contained luminaires are optionally available with a new LiFePO4 battery, which enables use at temperatures from -15°C to +40°C. The article number is supplemented by the suffix -TT.

WALL MOUNTING

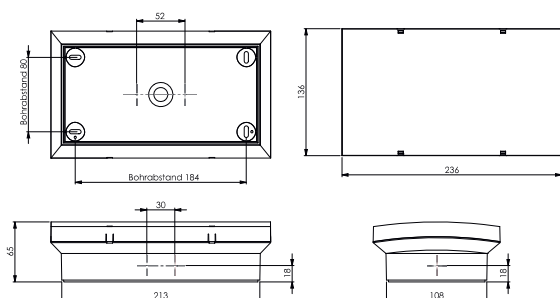

CEILING MOUNTING

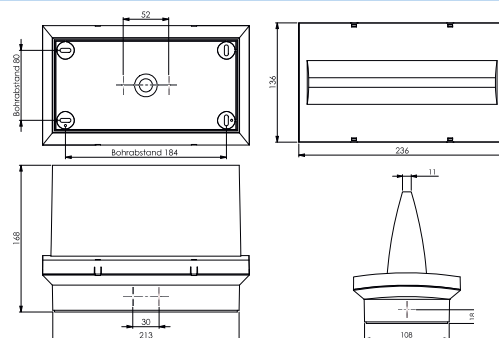





GENERAL INFORMATION

FACTS

- Plastic, white
- 30m Viewing distance
- Complete set of pictographs (ISO 7010)
- KCW: IP54, optional IP64
- KCD: IP40
- Wall or ceiling mounting
- SelfContained: -5° to +40°C
- Central battery: -30° to +40°C

Convex exit sign made of plastic for wall or ceiling mounting. Sign with pluggable, solvent free, internally mounted pictograph. Pictogram set included.

This luminaire can be used without pictogram as an emergency lighting luminaire with a clear cover.

Escape route/Exit sign/ emergency luminaire according to EN 60598-1, EN 60598-2-22 and EN 1838 norms.

DESIGN LUMINAIRES

DYNAMIC LUMINAIRES

UNIVERSAL LUMINAIRES

INDUSTRIAL LUMINAIRES

GENERAL LIGHTING WITH EMERGENCY LIGHT

WIRELESS MONITORING

ACCESSORIES

MODULES



KCW

PLASTIC LUMINAIRE

KCW

IP54 IP64 optional IK 06

SELF-CONTAINED LUMINAIRES WITH SELFCONTROL MODULE						
LED, 1h, 230V AC	KCW411SC	1 h		6,1 W - 300 lm	6,4V/1,6Ah LiFeP04	
LED, 1h, 230V AC	KCW421SC	1 h		6 W - 520 lm	6,4V/1,6Ah LiFeP04	
LED, 3h, 230V AC	KCW413SC	3 h		6,1 W - 150 lm	6,4V/1,6Ah LiFeP04	
LED, 3h, 230V AC	KCW423SC	3 h		7,1 W - 520 lm	6,4V/3,3Ah LiFeP04	
LED, 8h, 230V AC	KCW418SC	8 h		6,7 W - 160 lm	6,4V/3,3Ah LiFeP04	
LED, 8h, 230V AC	KCW428SC	8 h		7,1 W - 220 lm	6,4V/3,3Ah LiFeP04	
SELF-CONTAINED LUMINAIRES WITH WIRELESS PROFESSIONAL MODULE (SWITCHABLE)						
LED, 1h, 230V AC	KCW411WL	1 h		5,3 W - 335 lm	6,4V/1,2Ah LiFeP04	
LED, 3h, 230V AC	KCW413WL	3 h		7,5 W - 180 lm	6,4V/3,3Ah LiFeP04	
LED, 8h, 230V AC	KCW418WL	8 h		7,5 W	6,4V/3,3Ah LiFeP04	
LUMINAIRES FOR CORE COMPACT LOW-POWER SYSTEMS 24V AC/DC INCL. MONITORING MODULE						
LED, 24V AC/DC	KCW519CC	CPS		3,8 W - 335 lm		
LED, 24V AC/DC	KCW529CC	CPS		3,8 W - 520 lm		
LUMINAIRES FOR CENTRAL BATTERY SYSTEMS AC/DC						
LED, 230V AC/DC	KCW019	CPS		4,5 W - 300 lm		
LED, 230V AC/DC	KCW029	CPS		4,6 W - 520 lm		
LUMINAIRES FOR CENTRAL BATTERY SYSTEMS AC/DC INCL. MONITORING MODULE						
LED, 230V AC/DC	KCW019ML	CPS		5,2 W - 300 lm		
LED, 230V AC/DC	KCW029ML	CPS		5,2 W - 520 lm		



All self-contained luminaires are optionally available with a new LiFeP04 battery, which enables use at temperatures from -15°C to +40°C. The article number is supplemented by the suffix -TT. These versions always come in insulation class IP64.

The previous versions with external battery housing (-COOL) or heating elements (-EHE) are no longer applicable.

KCW WALL-/ CEILING MOUNTING

Dimensions KC wall

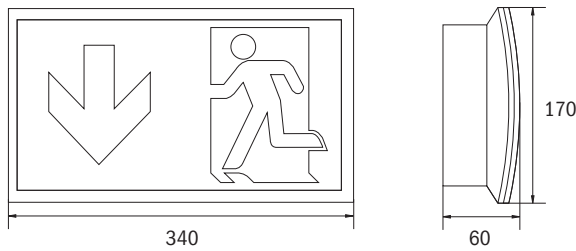

Drilling distances KC

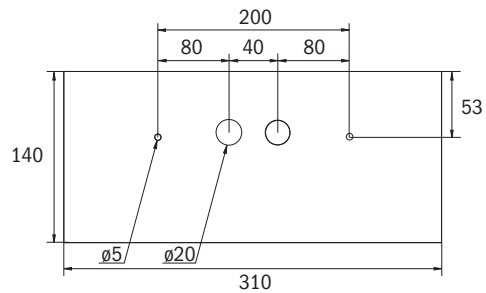

Rain cover KCRD for KCW (with IP65 Option only)

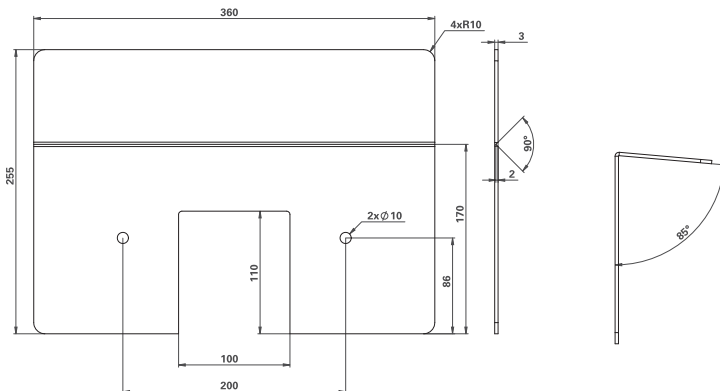

All Dimensions in mm

Distance table KCW029 for plane emergency routes

Mounting height (m)					
2.00	7.46	16.44	15.49	8.50	3.33
2.50	8.72	19.75	18.20	9.18	3.44
3.00	9.81	22.80	20.34	9.57	3.45
3.50	10.77	25.37	22.28	9.86	3.50
4.00	10.99	27.55	22.99	9.84	3.48

The distance table is based on the following parameters: Maintenance factor: 0.8; emergency lighting factor 1.00; Minimum illumination on the center line: 1.00 lux; Minimum illumination on the half width of the rescue

route: 0.50 lux, uniformity on the midline maximum 40:1; Width of the rescue route 2.00m

PLASTIC LUMINAIRE

KCD

IP40

IP64
optional

SELF-CONTAINED LUMINAIRES WITH SELFCONTROL MODULE					
LED, 1h, 230V AC	KCD411SC	1 h	6,1 W - 320 lm	6,4V/1,6Ah LiFeP04	
LED, 3h, 230V AC	KCD413SC	3 h	6,1 W - 225 lm	6,4V/1,6Ah LiFeP04	
LED, 8h, 230V AC	KCD418SC	8 h	6,7 W - 160 lm	6,4V/1,6Ah LiFeP04	
SELF-CONTAINED LUMINAIRES WITH WIRELESS PROFESSIONAL MODULE (SWITCHABLE)					
LED, 1h, 230V AC	KCD411WL	1 h	5,3 W - 355 lm	6,4V/1,2Ah LiFeP04	
LED, 3h, 230V AC	KCD413WL	3 h	5,3 W - 180 lm	6,4V/3,3Ah LiFeP04	
LED, 8h, 230V AC	KCD418WL	8 h	5,5 W	6,4V/3,3Ah LiFeP04	
LUMINAIRES FOR CORE COMPACT LOW-POWER SYSTEMS 24V AC/DC INCL. MONITORING MODULE					
LED, 24V AC/DC	KCD519CC	CPS	3,8 W - 335 lm		
LUMINAIRES FOR CENTRAL BATTERY SYSTEMS AC/DC					
LED, 230V AC/DC	KCD019	CPS	4,5 W - 300 lm		
LED, 230V AC/DC	KCD029	CPS	4,6 W - 520 lm		
LUMINAIRES FOR CENTRAL BATTERY SYSTEMS AC/DC INCL. MONITORING MODULE					
LED, 230V AC/DC	KCD019ML	CPS	5,2 W - 300 lm		
LED, 230V AC/DC	KCD029ML	CPS	5,2 W - 520 lm		

KCD CEILING MOUNTING

Dimensions KC ceiling

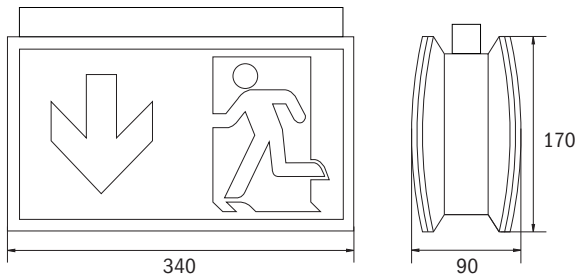

Drilling distances KC

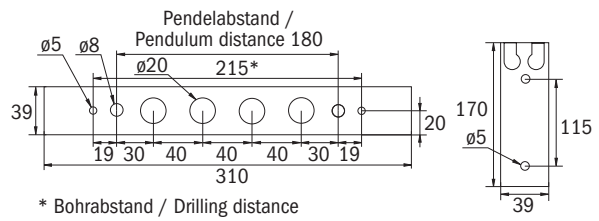
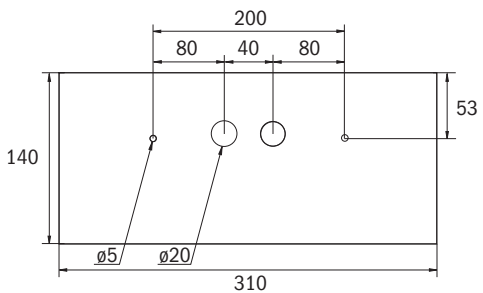

All Dimensions in mm

ACCESSORIES

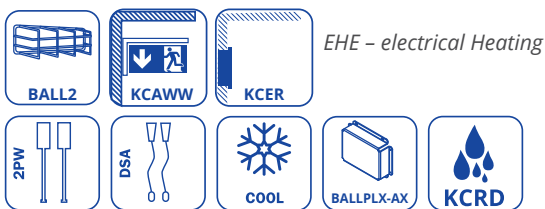



 **KD / KL**
PLASTIC LUMINAIRE



GENERAL INFORMATION

FACTS

- Plastic, white
- 22m (KD) or 34m (KL) Viewing distance
- Complete set of pictographs (ISO 7010)
- IP43
- Universal mounting incl. wall bracket
- SelfContained: -5° to +40°C
Central battery: -30° to +40°C

Slim design plastic luminaire for universal mounting (wall/ ceiling or as wall bracket with supplied adapter).

This luminaire provides additional downward lighting to enhance safety at the egress route. Applicable for maintained or non-maintained operation mode.

Improved reliability through easy to install universal use of pictograms. Signs according to EN 60598-1, EN 60598-2-22 and EN 1838 norms.



DESIGN LUMINAIRES



DYNAMIC LUMINAIRES

UNIVERSAL LUMINAIRES

INDUSTRIAL LUMINAIRES

GENERAL LIGHTING WITH EMERGENCY LIGHT

WIRELESS MONITORING













ACCESSORIES

MODULES



PLASTIC LUMINAIRE

KD (22M)

					
SELF-CONTAINED LUMINAIRES WITH SELFCONTROL MODULE					
LED, 1h, 230V AC	KDU411SC	1 h	4,3 W	3,2V / 1,2 Ah LiFePO4	
LED, 3h, 230V AC	KDU413SC	3 h	4,3 W	6,4V/1,2Ah LiFePO4	
SELF-CONTAINED LUMINAIRES WITH WIRELESS PROFESSIONAL MODULE (SWITCHABLE)					
LED, 1h, 230V AC	KDU411WL	1 h	4,7 W	6,4V / 1,2 Ah LiFePO4	
LED, 3h, 230V AC	KDU413WL	3 h	4,7 W	6,4V / 1,2 Ah LiFePO4	
LED, 8h, 230V AC	KDU418WL	8 h	4,7 W	6,4V / 1,2 Ah LiFePO4	
LUMINAIRES FOR CORE COMPACT LOW-POWER SYSTEMS 24V AC/DC INCL. MONITORING MODULE					
LED, 24V AC/DC	KDU519CC	CPS	3,6 W		
LUMINAIRES FOR CENTRAL BATTERY SYSTEMS AC/DC					
LED, 230V AC/DC	KDU019	CPS	4,5 W		
LUMINAIRES FOR CENTRAL BATTERY SYSTEMS AC/DC INCL. MONITORING MODULE					
LED, 230V AC/DC	KDU019ML	CPS	5,2 W		

UNIVERSAL MOUNTING

Dimensions KD wall

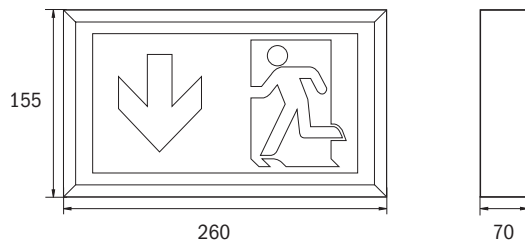

Dimensions KD ceiling

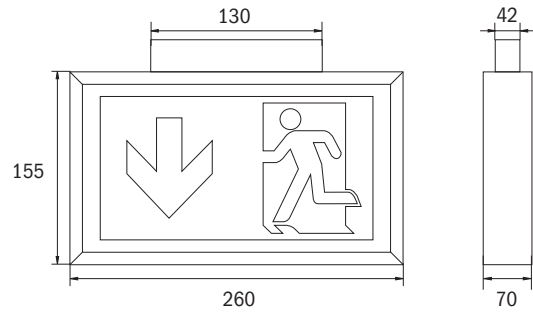

Drilling distances KD wall

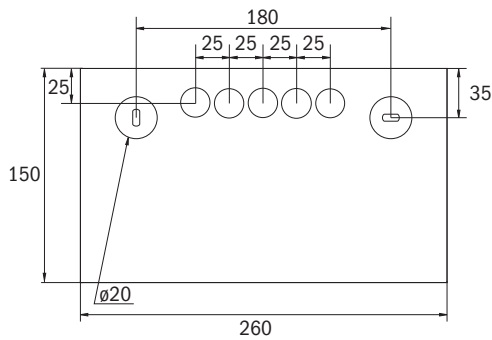

Drilling distances KD ceiling

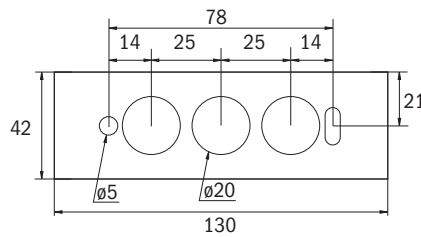













All Dimensions in mm

ACCESSORIES



PLASTIC LUMINAIRE

KL (34M)

					
SELF-CONTAINED LUMINAIRES WITH SELFCONTROL MODULE					
LED, 1h, 230V AC	KLU411SC	1 h	5,5 W	6,4V/1,6Ah LiFePO4	
LED, 3h, 230V AC	KLU413SC	3 h	4,1 W	6,4V/1,6Ah LiFePO4	
SELF-CONTAINED LUMINAIRES WITH WIRELESS PROFESSIONAL MODULE (SWITCHABLE)					
LED, 1h, 230V AC	KLU411WL	1 h	4,1 W	6,4V / 1,2 Ah LiFePO4	
LED, 3h, 230V AC	KLU413WL	3 h	4,1 W	6,4V / 1,2 Ah LiFePO4	
LED, 8h, 230V AC	KLU418WL	8 h	4,1 W	6,4V / 1,2 Ah LiFePO4	
LUMINAIRES FOR CORE COMPACT LOW-POWER SYSTEMS 24V AC/DC INCL. MONITORING MODULE					
LED, 24V AC/DC	KLU519CC	CPS	3,6 W		
LUMINAIRES FOR CENTRAL BATTERY SYSTEMS AC/DC					
LED, 230V AC/DC	KLU019	CPS	4,5 W		
LUMINAIRES FOR CENTRAL BATTERY SYSTEMS AC/DC INCL. MONITORING MODULE					
LED, 230V AC/DC	KLU019ML	CPS	5,2 W		

UNIVERSAL MOUNTING

Dimensions KL wall

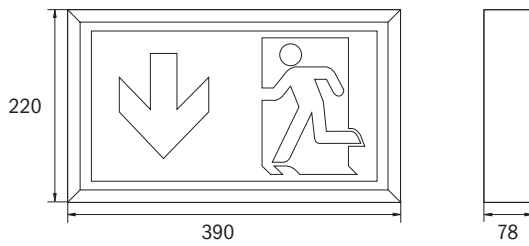

Drilling distances KL wall

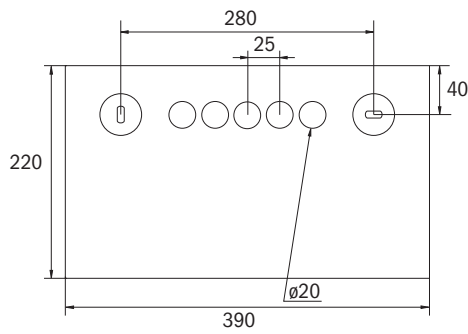

All Dimensions in mm

Dimensions KL ceiling

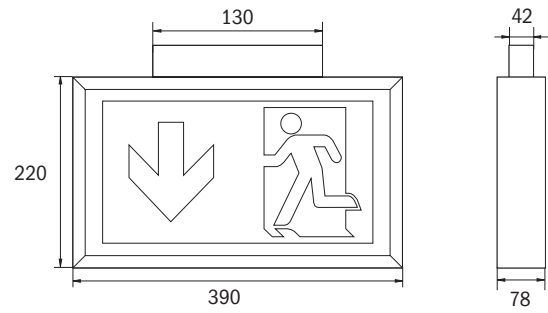

Drilling distances KL ceiling

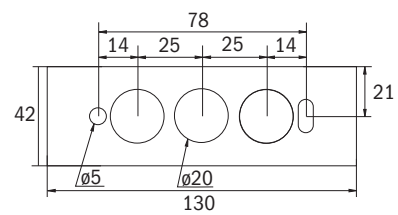

ACCESSORIES

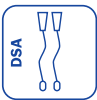
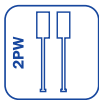

When mounting with cord suspension or pendulum the protection class is reduced to IP20.



 **LM / LX / LS**
ALUMINIUM PROFILED LUMINAIRES



GENERAL INFORMATION

FACTS

- Aluminium housing
- 22m (LM), 34m (LX) or 56m (LS) viewing distance
- Complete set of pictographs (ISO 7010) - not for LS
- IP40
- Available for wall or ceiling mounting
- SelfContained: -5° to +40°C
Central battery: -30° to +40°C

Luminare designed in slender aluminum profile, matte anodized, finishing for ceiling mounting with additional downward lighting, enhancing safety. Toolless mounting chassis. Applicable for maintained or non-maintained operation mode.

Improved reliability through easy to install universal use of pictograms. Pictogram set (left, right, up, down signs) included (not for LS). Signs according to EN 60598-1, EN 60598-2-22 and EN 1838 norms.



DESIGN LUMINAIRES



DYNAMIC LUMINAIRES

UNIVERSAL LUMINAIRES

INDUSTRIAL LUMINAIRES

GENERAL LIGHTING WITH EMERGENCY LIGHT















WIRELESS MONITORING

ACCESSORIES

MODULES

ALUMINIUM PROFILED LUMINAIRES

LM (22m)

						
SELF-CONTAINED LUMINAIRES WITH SELFCONTROL MODULE						
LED, 1h, 230V AC	LMD411SC	LMW411SC	1 h	4,3 W	6,4V/1,2 Ah LiFePO4	
LED, 3h, 230V AC	LMD413SC	LMW413SC	3 h	4,3 W	6,4V/1,2Ah LiFePO4	
SELF-CONTAINED LUMINAIRES WITH WIRELESS PROFESSIONAL MODUL (NOT SWITCHABLE)						
LED, 1h, 230V AC	LMD011WL	LMW011WL	1 h	7,5 W	12V/0,8Ah NiMH	
LED, 3h, 230V AC	LMD013WL	LMW013WL	3 h	7,5 W	12V/0,8Ah NiMH	
LED, 8h, 230V AC	LMD018WL	LMW018WL	8 h	7,5 W	12V/0,8Ah NiMH	
LUMINAIRES FOR CENTRAL BATTERY SYSTEMS AC/DC						
LED, 230V AC/DC	LMD019	LMW019	CPS	4,5 W		
LUMINAIRES FOR CENTRAL BATTERY SYSTEMS AC/DC INCL. MONITORING MODULE						
LED, 230V AC/DC	LMD019ML	LMW019ML	CPS	5,2 W		

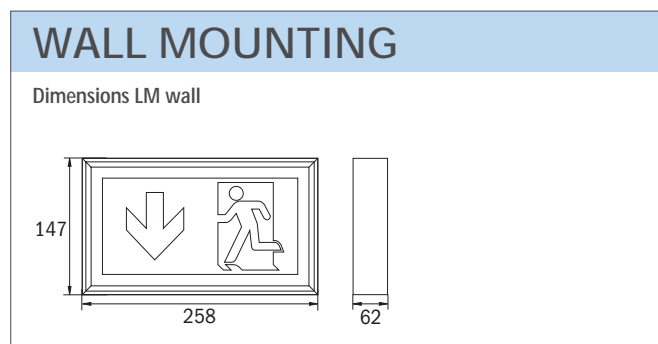
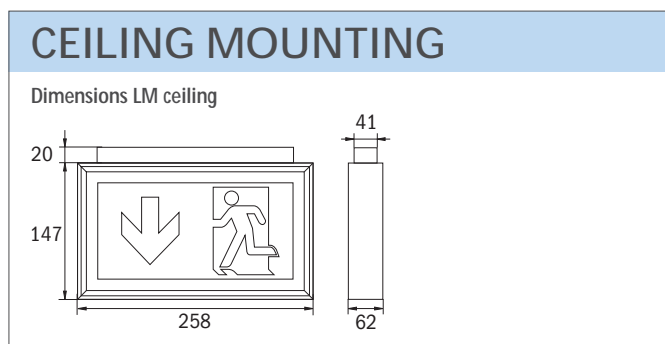



All Dimensions in mm

ACCESSORIES

DSA

2PS

AWW



AWM/AWX

BALL 1

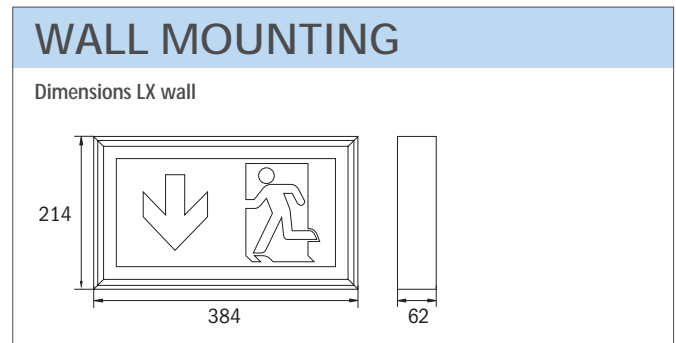
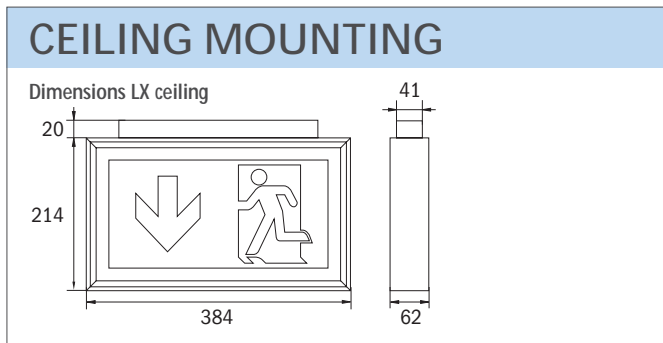

LX (34m)

SELF-CONTAINED LUMINAIRES WITH SELFCONTROL MODULE						
LED, 1h, 230V AC	LXD411SC	LXW411SC	1 h	5,5 W	6,4V/1,6Ah LiFeP04	
LED, 3h, 230V AC	LXD413SC	LXW413SC	3 h	4,1 W	6,4V/1,6Ah LiFeP04	
SELF-CONTAINED LUMINAIRES WITH WIRELESS PROFESSIONAL MODUL (NOT SWITCHABLE)						
LED, 1h, 230V AC	LXD011WL	LXW011WL	1 h	7,5 W	12V/0,8Ah NiMH	
LED, 3h, 230V AC	LXD013WL	LXW013WL	3 h	7,5 W	12V/0,8Ah NiMH	
LUMINAIRES FOR CENTRAL BATTERY SYSTEMS AC/DC						
LED, 230V AC/DC	LXD019	LXW019	CPS	4,5 W		
LUMINAIRES FOR CENTRAL BATTERY SYSTEMS AC/DC INCL. MONITORING MODULE						
LED, 230V AC/DC	LXD019ML	LXW019ML	CPS	5,2 W		



All Dimensions in mm

ACCESSORIES

BALL 2











AWM/AWX

DSA

2PS

ALUMINIUM PROFILED LUMINAIRES

LS (56M) – NO PICTOGRAPH SET INCLUDED; PLEASE SPECIFY PICTOGRAPH

						
SELF-CONTAINED LUMINAIRES WITH SELFCONTROL MODULE						
LED, 1h, 230V AC	LSD411SC	LSW411SC	1 h	4,2 W	6,4V/1,2 Ah LiFePO4	
LED, 3h, 230V AC	LSD413SC	LSW413SC	3 h	4,2 W	6,4V/1,2Ah LiFePO4	
SELF-CONTAINED LUMINAIRES WITH WIRELESS PROFESSIONAL MODUL (NOT SWITCHABLE)						
LED, 1h, 230V AC	LSD011WL	LSW011WL	1 h	7,5 W	12V/0,8Ah NiMH	
LUMINAIRES FOR CENTRAL BATTERY SYSTEMS AC/DC						
LED, 230V AC/DC	LSD019	LSW019	CPS	8,3 W		
LUMINAIRES FOR CENTRAL BATTERY SYSTEMS AC/DC INCL. MONITORING MODULE						
LED, 230V AC/DC	LSD019ML	LSW019ML	CPS	9,3 W		

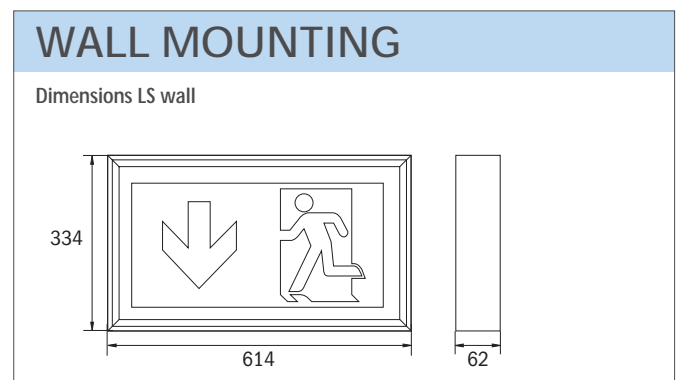
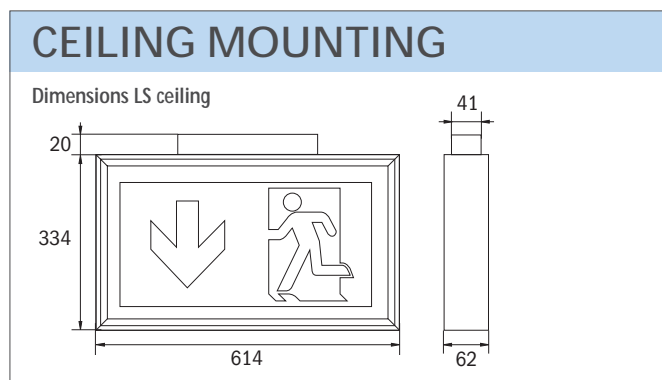

All Dimensions in mm

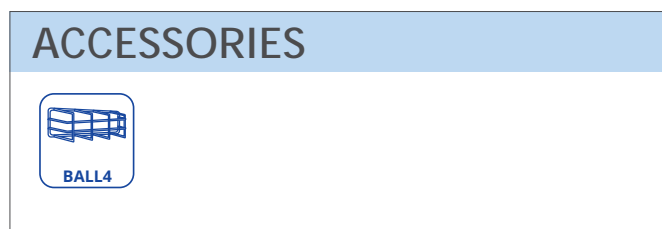



GENERAL INFORMATION

DESIGN LUMINAIRES

DYNAMIC LUMINAIRES

UNIVERSAL LUMINAIRES

INDUSTRIAL LUMINAIRES

GENERAL LIGHTING WITH EMERGENCY LIGHT

WIRELESS MONITORING

ACCESSORIES

MODULES







FACTS

- Plastic, white
- Complete set of pictograms (ISO 7010)
- IP65
- Available for wall or ceiling mounting
- SelfContained: -5° to +40°C
Central battery: -30° to +40°C

Exit sign / escape route light according to DIN EN 60598-1, DIN EN 60598-2-22 and DIN EN 1838

Classic bar-shaped polycarbonate luminaire for ceiling mounting. Straight lines as well as the robust construction allow versatile use.

Suitable for permanent or standby switching. Planning security through tool-free, variable use of the pictograms on site. Pictograms according to DIN EN ISO 7010 and DIN ISO 3864 (left, right, above, below) are included as standard in the scope of delivery.



Flexi Click



PLASTIC LUMINAIRE

SELF-CONTAINED LUMINAIRES WITH SELFCONTROL MODULE							
LED, 1h, 230V AC		KWIW421SC		1 h	6,4 W - 520 lm	6,4V/1,6Ah LiFePO4	
LED, 1h, 230V AC	KWID411SC	KWIW411SC		1 h	6,4 W	6,4V/1,6Ah LiFePO4	
LED, 3h, 230V AC	KWID413SC	KWIW413SC		3 h	6,4 W	6,4V/1,6Ah LiFePO4	
LED, 3h, 230V AC		KWIW423SC		3 h	6,7 W - 500 lm	6,4V/3,3Ah LiFePO4	
SELF-CONTAINED LUMINAIRES WITH WIRELESS PROFESSIONAL MODUL							
LED, 1h, 230V AC		KWIW421WL		1 h	7,5 W - 520 lm	6,4V/1,2Ah LiFePO4	
LED, 1h, 230V AC	KWID411WL	KWIW411WL		1 h	5,3 W	6,4V/1,2 Ah LiFePO4	
LED, 3h, 230V AC		KWIW423WL		3 h	7,5 W - 520 lm	6,4V/3,3 Ah LiFePO4	
LED, 3h, 230V AC	KWID413WL	KWIW413WL		3 h	5,3 W	6,4V/1,2 Ah LiFePO4	
LED, 8h, 230V AC		KWIW428WL		8 h	7,5 W - 245 lm	6,4V/3,3 Ah LiFePO4	
LED, 8h, 230V AC	KWID418WL	KWIW418WL		8 h	5,5 W	6,4V/3,3 Ah LiFePO4	
LUMINAIRES FOR CORE COMPACT LOW-POWER SYSTEMS 24V AC/DC INCL. MONITORING MODULE							
LED, 24V AC/DC	KWID519CC	KWIW519CC		CPS	3,8 W - 335 lm		
LED, 24V AC/DC	KWID529CC	KWIW529CC		CPS	3,8 W - 520 lm		
LUMINAIRES FOR CENTRAL BATTERY SYSTEMS AC/DC							
LED, 230V AC/DC		KWIW029		CPS	4,6 W - 520 lm		
LUMINAIRES FOR CENTRAL BATTERY SYSTEMS AC/DC INCL. MONITORING MODULE							
LED, 230V AC/DC		KWIW029ML		CPS	5,2 W - 520 lm		
LED, 230V AC/DC	KWID019ML	KWIW019ML		CPS	5,2 W		
LED, 230V AC/DC		KWIW039ML		CPS	9,4 W - 1050 lm		

All self-contained luminaires are optionally available with a new LiFePO4 battery, which enables use at temperatures from -15°C to +40°C. The article number is supplemented by the suffix -TT. For these luminaires the use of pendant fittings or cord suspensions is not recommended.

KWID high dome, KWIW with ERT-LED clear flat dome

Distance table for KWIW039ML for plane emergency routes

Mounting height (m)					
2.00	10.57	24.28	16.58	9.30	3.71
2.50	12.15	27.65	18.85	10.15	3.96
3.00	13.57	31.05	20.91	10.66	4.18
3.50	14.85	34.17	22.64	11.18	4.35
4.00	16.03	37.04	24.21	11.64	4.49

The distance table is based on the following parameters: Maintenance factor: 0.8; emergency lighting factor 1.00; Minimum illumination on the center line: 1.00 lux; Minimum illumination on the half width of the rescue

route: 0.50 lux, uniformity on the midline maximum 40:1; Width of the rescue route 2.00m

CEILING MOUNTING / WALL MOUNTING

Dimensions KWI ceiling

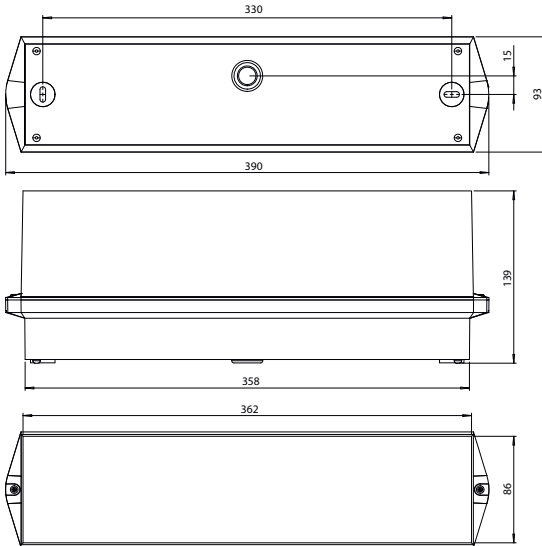

Dimensions KWI wall

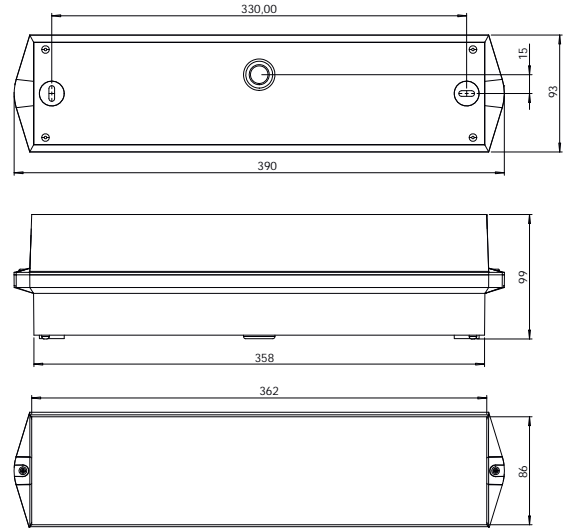

Dimensions KWIE recessed frame

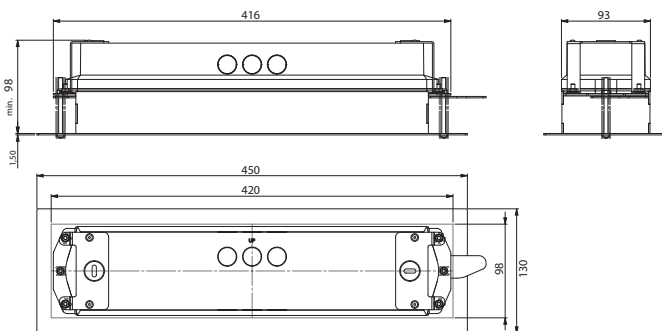

Drilling distances KWI ceiling / wall



All Dimensions in mm

ACCESSORIES

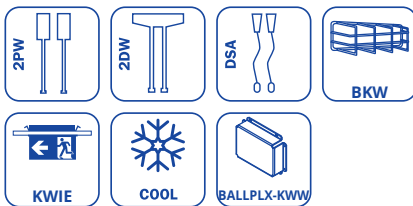

When mounting with cord suspension or pendulum the protection class is reduced to IP20.

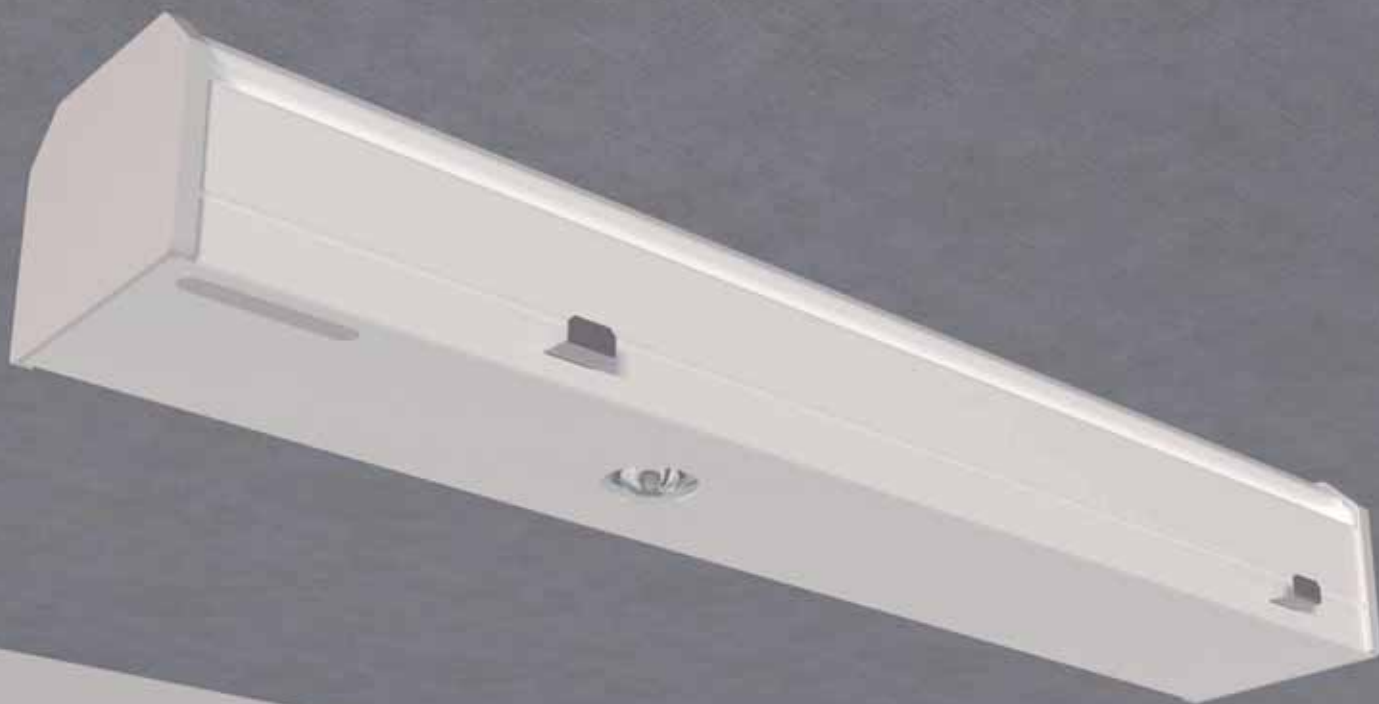

*Flexi
Click*

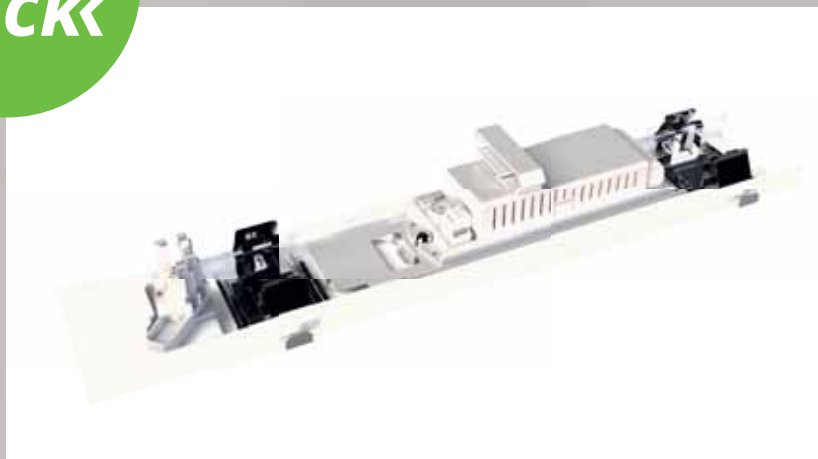

LBLT

EMERGENCY LIGHTING INSERT FOR TRILUX LIGHT STRIPS



FACTS

- Emergency lighting insert for 3-phase track systems
- Ambient temperature: -5° to +40°C
- IP20

Emergency route luminaire insert with ERT LED for Trilux E-Line mounting rail profile 07650 with 7 wires.

The innovative integrated lens carrier with quick mounting device enables the flexible use of different lens types depending on the application.

Round and corridor lenses are included in the scope of delivery for each light and enable perfect adaptation to the respective installation situation. Additional lenses, e.g. for high ceilings, are available separately.

Luminaires from the KMU, KSU/KSC and ILD series are also available for installation in 3-phase power rails.

SELF-CONTAINED LUMINAIRES WITH SELFCONTROL MODULE					
LED, 1h, 230V AC	LBLT431SC	1 h	4,2 W – 255 lm	6,4V/1,2Ah LiFeP04	
LUMINAIRES FOR CENTRAL BATTERY SYSTEMS AC/DC INCL. MONITORING MODULE					
LED, 230V AC/DC	LBLT039ML	CPS	5,4 W – 470 lm		

Distance Table for LBLT039ML with corridor lens for plane emergency routes (additional distance tables on our website)

Mounting height (m)					
2.50	3.23	8.40	13.70	18.97	8.34
3.00	3.35	8.79	15.04	21.30	9.30
3.50	3.42	9.12	16.26	23.44	10.17
4.00	3.47	9.36	17.38	25.41	10.94
4.50	3.51	9.56	18.40	27.23	11.08
5.00	3.53	9.70	19.20	28.94	11.15
5.50	3.44	9.80	19.44	30.23	10.30
6.00	3.28	9.86	18.02	31.15	6.60
6.50	3.01	9.96	15.39	28.70	4.71
7.00	2.52	9.99	13.76	27.54	3.16

The distance table is based on the following parameters: Maintenance factor: 0.8; emergency lighting factor 1.00; Minimum illumination on the center line: 1.00 lux; Minimum illumination on the half width of the rescue

route: 0.50 lux, uniformity on the midline maximum 40:1; Width of the rescue route 2.00m

POWER RAIL MOUNTING

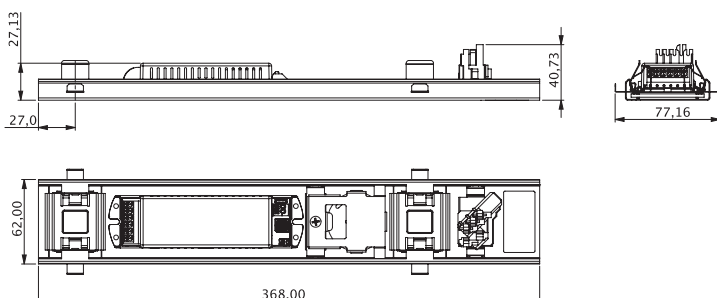

All dimensions in mm



 **WH**
POLYCARBONATE CUBIC LUMINAIRES

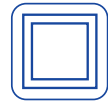

FACTS

- Plastic, white
- Viewing Distance : 30m / 50m
- IP65
- Mounting:
Ceiling, Pendulum, Chain
- Self-Contained: -5° to +40°C
Central battery: -20° to +40°C

Due to the cube shape, this plastic luminaire is easily recognizable from four sides. It is ideal for applications at crossroads, such as in department stores with aisles.

Planning security is provided by logically specified imprinted pictograms.

LED exit sign luminaire according to DIN EN 60598-1, DIN EN 60598-2-22, DIN EN 7010 and DIN EN 1838.

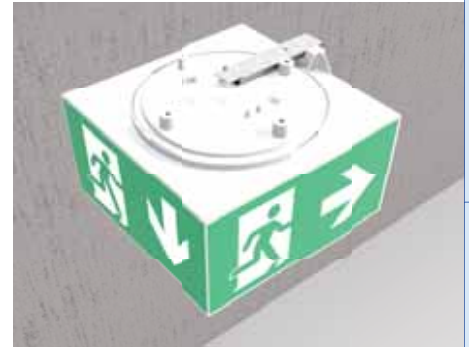

WHX (30M)

SELF-CONTAINED LUMINAIRES WITH SELFCONTROL MODULE					
LED, 1h, 230V AC	WHXD411SC		1 h	6,4 W	6,4V/1,6Ah LiFeP04
LED, 3h, 230V AC	WHXD413SC		3 h	6,7 W	6,4V/3,3Ah LiFeP04
LED, 8h, 230V AC	WHXD418SC		8 h	7,1 W	6,4V/3,3Ah LiFeP04
SELF-CONTAINED LUMINAIRES WITH WIRELESS PROFESSIONAL MODUL					
LED, 1h, 230V AC	WHXD411WL		1 h	7,5 W	6,4V/1,2Ah LiFeP04
LED, 3h, 230V AC	WHXD413WL		3 h	7,5 W	6,4V/3,3Ah LiFeP04
LED, 8h, 230V AC	WHXD418WL		8 h	7,5 W	6,4V/3,3Ah LiFeP04
LUMINAIRES FOR CORE COMPACT LOW-POWER SYSTEMS 24V AC/DC INCL. MONITORING MODULE					
LED, 24V AC/DC	WHXD519CC		CPS	3,8 W	
LUMINAIRES FOR CENTRAL BATTERY SYSTEMS AC/DC					
LED, 230V AC/DC	WHXD019		CPS	4,6 W	
LUMINAIRES FOR CENTRAL BATTERY SYSTEMS AC/DC INCL. MONITORING MODULE					
LED, 230V AC/DC	WHXD019ML		CPS	5,2 W	



All self-contained luminaires are optionally suitable with a low-temperature battery down to -15°C (addition -TT to the article number).

CEILING MOUNTING

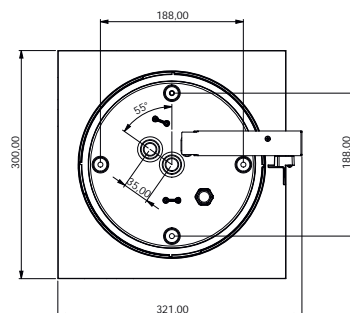
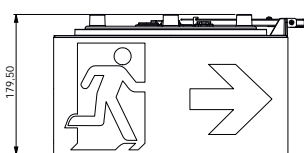

ACCESSORIES



WKO: 4 chain eyelets for suspended mounting



DSA-Y4M: Cord Suspension, 4m



DSA-Y4M-APA: Cord Suspension, 4m incl. surface mounted ceiling adapter

POLYCARBONATE CUBIC LUMINAIRES

WHG (50M)

SELF-CONTAINED LUMINAIRES WITH SELFCONTROL MODULE						
LED, 1h, 230V AC	WHGD411SC	5 GARANTIE WARRANTY	1 h	6,4 W	6,4V/1,6Ah LiFeP04	
LED, 3h, 230V AC	WHGD413SC	5 GARANTIE WARRANTY	3 h	6,7 W	6,4V/3,3Ah LiFeP04	
LED, 8h, 230V AC	WHGD418SC	5 GARANTIE WARRANTY	8 h	7,1 W	6,4V/3,3Ah LiFeP04	
SELF-CONTAINED LUMINAIRES WITH WIRELESS PROFESSIONAL MODUL						
LED, 1h, 230V AC	WHGD411WL	5 GARANTIE WARRANTY	1 h	7,5 W	6,4V/1,2Ah LiFeP04	
LED, 3h, 230V AC	WHGD413WL	5 GARANTIE WARRANTY	3 h	7,5 W	6,4V/3,3Ah LiFeP04	
LED, 8h, 230V AC	WHGD418WL	5 GARANTIE WARRANTY	8 h	7,5 W	6,4V/3,3Ah LiFeP04	
LUMINAIRES FOR CORE COMPACT LOW-POWER SYSTEMS 24V AC/DC INCL. MONITORING MODULE						
LED, 24V AC/DC	WHGD519CC		CPS	3,8 W		
LUMINAIRES FOR CENTRAL BATTERY SYSTEMS AC/DC						
LED, 230V AC/DC	WHGD019		CPS	4,6 W		
LUMINAIRES FOR CENTRAL BATTERY SYSTEMS AC/DC INCL. MONITORING MODULE						
LED, 230V AC/DC	WHGD019ML		CPS	5,2 W		



All self-contained luminaires are optionally suitable with a low-temperature battery down to -15°C (addition -TT to the article number).



CEILING MOUNTING

Dimensions WHG

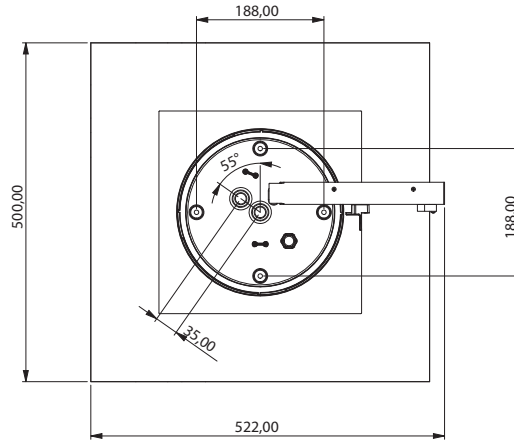
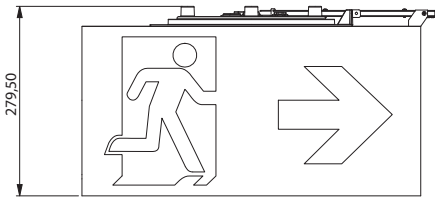

ACCESSORIES



WKO: 4 chain eyelets for suspended mounting



DSA-Y4M: Cord Suspension



DSA-Y4M-APA: Cord Suspension incl. surface mounted ceiling adapter

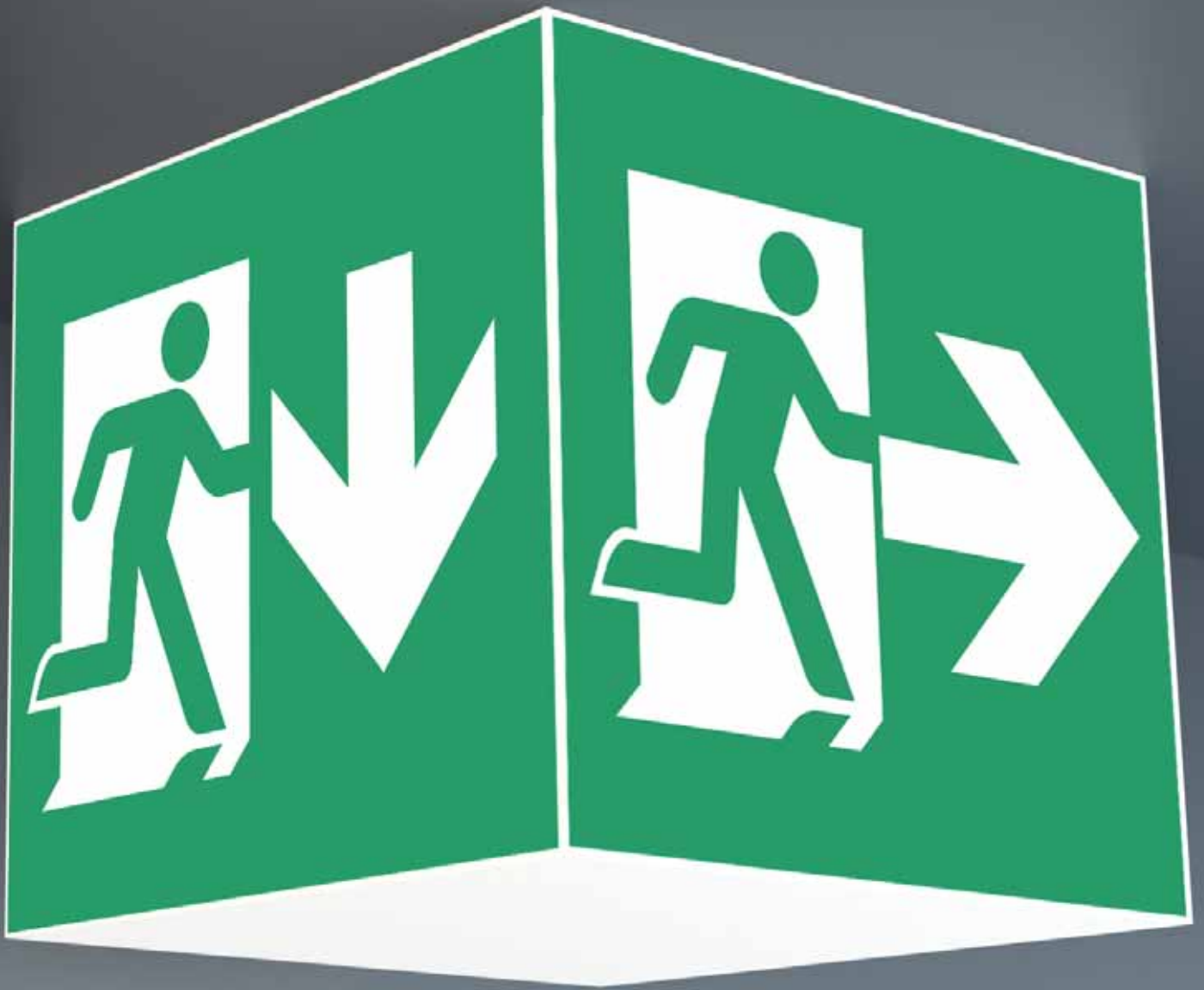

WK / WG / WX

POLYCARBONATE CUBIC LUMINAIRES



FACTS

- Polycarbonate, white
- Recognition distance
WK: 36m, WG: 46m, WX: 90m
- IP20
- Mounting:
Wall, Ceiling, Pendulum, Chain
- Self-contained: -5° to +40°C
Central battery systems:
-30° to +40°C

Due to the cube shape, this plastic lamp is easily recognizable from four sides. This makes it ideal for applications at crossings, such as in department stores with aisles.

Planning security is provided by logically specified, printed pictograms.

LED escape sign luminaire according to DIN EN 60598-1, DIN EN 60598-2-22, DIN EN 7010 and DIN EN 1838.



WK (36M)

SELF-CONTAINED LUMINAIRES WITH SELFCONTROL MODULE						
LED, 1h, 230V AC	WKD411SC	WKW411SC	1 h		6,4 W	6,4V/1,6Ah LiFeP04
LED, 3h, 230V AC	WKD413SC	WKW413SC	3 h		4,2 W	6,4V/3,3Ah LiFeP04
SELF-CONTAINED LUMINAIRES WITH WIRELESS PROFESSIONAL MODULE						
LED, 1h, 230V AC	WKD011WL	WKW011WL	1 h		7,5 W	12V/0,8Ah NiMH
LED, 3h, 230V AC	WKD013WL	WKW013WL	3 h		7,5 W	12V/0,8Ah NiMH
LUMINAIRES FOR CENTRAL BATTERY SYSTEMS AC/DC						
LED, 230V AC/DC	WKW019		CPS		4,5 W	
LUMINAIRES FOR CENTRAL BATTERY SYSTEMS AC/DC INCL. MONITORING MODULE						
LED, 230V AC/DC	WKD019ML		CPS		5,2 W	

CEILING / WALL MOUNTING

Dimensions WK

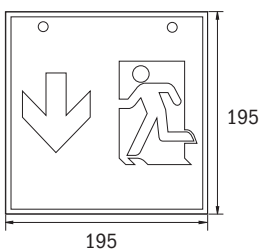



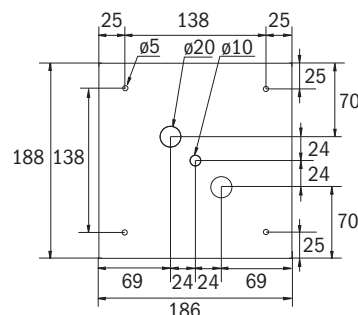











Drilling distances WK















POLYCARBONATE CUBIC LUMINAIRES

WG (46M)

						
SELF-CONTAINED LUMINAIRES WITH SELFCONTROL MODULE						
LED, 1h, 230V AC	WGD411SC	WGW411SC	1 h 	6,4 W	6,4V/1,6Ah LiFeP04	
LED, 3h, 230V AC	WGD413SC	WGW413SC	3 h 	4,2 W	6,4V/3,3Ah LiFeP04	
SELF-CONTAINED LUMINAIRES WITH WIRELESS PROFESSIONAL MODULE						
LED, 1h, 230V AC	WGD011WL	WGW011WL	1 h	7,5 W	12V/0,8Ah NiMH	
LED, 3h, 230V AC	WGD013WL	WGW013WL	3 h	7,5 W	12V/0,8Ah NiMH	
LED, 8h, 230V AC	WGD018WL		8 h	6,7 W	9,6V/2,0Ah NiMH	
LUMINAIRES FOR CENTRAL BATTERY SYSTEMS AC/DC						
LED, 230V AC/DC	WGD019	WGW019	CPS	4,5 W		
LUMINAIRES FOR CENTRAL BATTERY SYSTEMS AC/DC INCL. MONITORING MODULE						
LED, 230V AC/DC	WGD019ML		CPS	5,2 W		

WX (90M)

						
SELF-CONTAINED LUMINAIRES WITH SELFCONTROL MODULE						
LED, 1h, 230V AC	WXD411SC		1 h 	6,4 W	6,4V/1,6Ah LiFeP04	
LED, 3h, 230V AC	WXD413SC		3 h 	4,2 W	6,4V/3,3Ah LiFeP04	
SELF-CONTAINED LUMINAIRES WITH WIRELESS PROFESSIONAL MODULE						
LED, 1h, 230V AC	WXD011WL		1 h	7,5 W	12V/0,8Ah NiMH	
LED, 3h, 230V AC	WXD013WL		3 h	7,5 W	12V/0,8Ah NiMH	
LUMINAIRES FOR CENTRAL BATTERY SYSTEMS AC/DC						
LED, 230V AC/DC	WXD019		CPS	4,5 W		
LUMINAIRES FOR CENTRAL BATTERY SYSTEMS AC/DC INCL. MONITORING MODULE						
LED, 230V AC/DC	WXD019ML		CPS	5,2 W		



CEILING / WALL MOUNTING

Dimensions WG

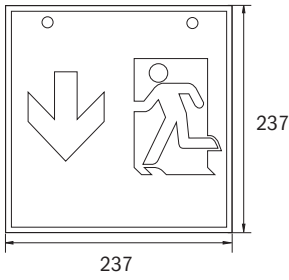

Drilling distances WG

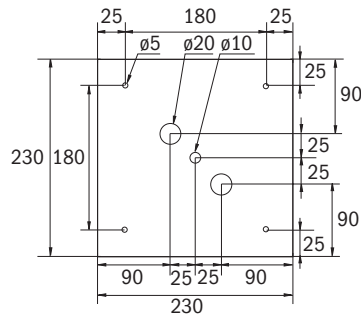

CEILING / WALL MOUNTING

Dimensions WX

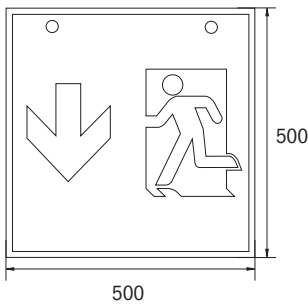

Drilling distances WX

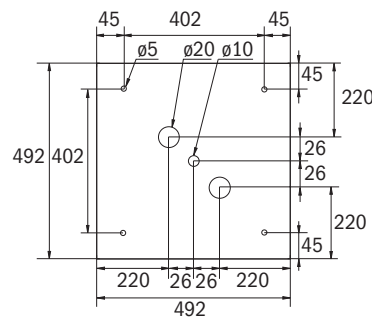

ACCESSORIES

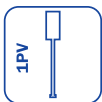

WK



WKO: 4 chain eyelets for suspended mounting



WFXW

POLYCARBONATE CUBIC LUMINAIRES

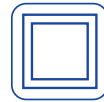

FACTS

- Polycarbonate, white
- Recognition distance 60m
- IP65
- Wall mounting
- Self-contained luminaires:
-5° to +40°C
Central battery systems:
-20° to +40°C

Exit sign in square format for marking the escape and rescue routes with installation-friendly bayonet lock. Included in delivery is a standard pictogram (right, left, top or down) as specified.

Optionally, it is possible to use the luminaire to mark other ancillary rooms.



SELF-CONTAINED LUMINAIRES WITH SELFCONTROL MODULE					
LED, 1h, 230V AC	WFXW411SC	1 h	6,4 W	6,4V/1,6Ah LiFeP04	
LED, 3h, 230V AC	WFXW413SC	3 h	6,7 W	6,4V/3,3Ah LiFeP04	
LED, 8h, 230V AC	WFXW018SC	8 h	7,1 W	9,6V/2,0Ah NiMH	
SELF-CONTAINED LUMINAIRES WITH WIRELESS PROFESSIONAL MODULE					
LED, 1h, 230V AC	WFXW411WL	1 h	7,5 W	6,4V/1,2Ah LiFeP04	
LED, 3h, 230V AC	WFXW413WL	3 h	7,5 W	6,4V/3,3Ah LiFeP04	
LED, 8h, 230V AC	WFXW418WL	8 h	7,5 W	6,4V/3,3Ah LiFeP04	
LUMINAIRES FOR CORE COMPACT LOW-POWER SYSTEMS 24V AC/DC INCL. MONITORING MODULE					
LED, 24V AC/DC	WFXW519CC	CPS	3,8 W		
LUMINAIRES FOR CENTRAL BATTERY SYSTEMS AC/DC					
LED, 230V AC/DC	WFXW019	CPS	4,6 W		
LUMINAIRES FOR CENTRAL BATTERY SYSTEMS AC/DC INCL. MONITORING MODULE					
LED, 230V AC/DC	WFXW019ML	CPS	5,2 W		

WALL MOUNTING

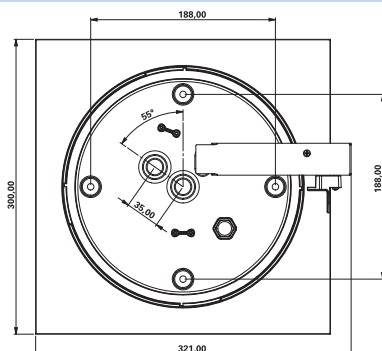

All dimensions in mm

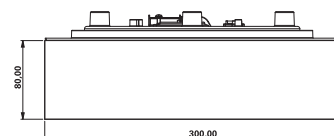
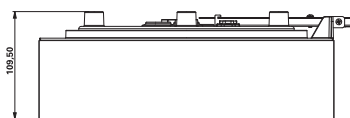



XI

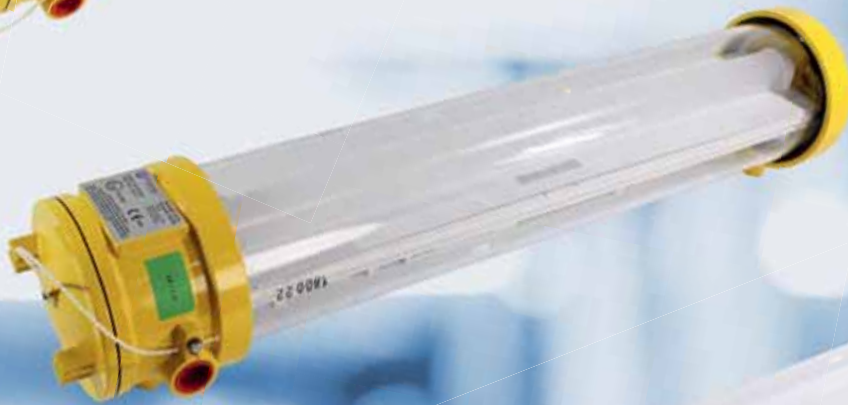

XM



XX

 **XI / XM / XX**
EXPLOSION PROOF LUMINAIRES



FACTS

- Explosion proof glass or polycarbonate cylinder
- IK05 (polycarbonate cylinder)
IK07 (glass cylinder)
- IP66
- Wall or ceiling mounting
- 0°C to +40°C (SelfContained)
-20°C to +40°C (CBS)

Explosion-proof LED glass or polycarbonate cylinder Safety light for gas and dust Ex zones. Available in three sizes with a luminous flux of up to 5000lm.

Prepared for two cable entries for through-wiring. By applying a pictogram can also be used as a exit sign.

Mounting options Wall or ceiling mounting with adapter or suspension with chain eye.

**According to 94/9/EG (ATEX)
Zone 1 / Zone 21 gas and dust**
• Ex d IIB T6 Gb / Ex d IIB T6 Gb
• Ex t IIIC T85°C Db

XI (GLASS CYLINDER)



SELF-CONTAINED LUMINAIRES WITH SELFCONTROL MODULE					
LED, 1h, 230V AC - Non maintained mode	XGIU001SC-BS *	1 h	5,8 W - 350 lm	3,6V/1,6Ah NiCd	
LED, 1h, 230V AC - maintained-/non-maintained mode	XGIU011SC *	1 h	24 W - 750 lm	6V/1,6Ah NiCd	
LED, 3h, 230V AC - Non maintained mode	XGIU003SC-BS *	3 h	6,9 W - 350 lm	3,6V/1,6Ah NiCd	
LUMINAIRES FOR CENTRAL BATTERY SYSTEMS AC/DC					
LED, 230V AC/DC	XGIU009 *	CPS	11 W - 1200 lm		
LED, 230V AC/DC	XGIU019 *	CPS	20 W - 2100 lm		
LUMINAIRES FOR CENTRAL BATTERY SYSTEMS AC/DC INCL. MONITORING MODULE					
LED, 230V AC/DC	XGIU009ML *	CPS	11 W - 1200 lm		
LED, 230V AC/DC	XGIU019ML *	CPS	20 W - 2100 lm		

*) only on request

XI (POLYCARBONATE CYLINDER)



SELF-CONTAINED LUMINAIRES WITH SELFCONTROL MODULE					
LED, 1h, 230V AC - Non maintained mode	XPIU001SC-BS *	1 h	5,8 W - 350 lm	3,6V/1,6Ah NiCd	
LED, 1h, 230V AC - maintained-/non-maintained mode	XPIU011SC *	1 h	24 W - 750 lm	6V/1,6Ah NiCd	
LED, 1h, 230V AC - maintained-/non-maintained mode	XPIU011SC-NI	1 h	24 W - 750 lm	6V/1,6Ah NiMH	
LED, 3h, 230V AC - Non maintained mode	XPIU003SC-BS *	3 h	6,9 W - 350 lm	3,6V/1,6Ah NiCd	
LUMINAIRES FOR CENTRAL BATTERY SYSTEMS AC/DC					
LED, 230V AC/DC	XPIU009 *	CPS	11 W - 1200 lm		
LED, 230V AC/DC	XPIU019 *	CPS	20 W - 2100 lm		
LUMINAIRES FOR CENTRAL BATTERY SYSTEMS AC/DC INCL. MONITORING MODULE					
LED, 230V AC/DC	XPIU009ML	CPS	11 W - 1200 lm		
LED, 230V AC/DC	XPIU019ML *	CPS	20 W - 2100 lm		

*) only on request

EXPLOSION PROOF LUMINAIRES

XM (GLASS CYLINDER)



SELF-CONTAINED LUMINAIRES WITH SELFCONTROL MODULE					
LED, 1h, 230V AC - Non-maintained mode	XGMU001SC-BS *	1 h	5,8 W - 700 lm	6V/1,6Ah NiCd	
LED, 1h, 230V AC - maintained-/Non-maintained mode	XGMU011SC *	1 h	40 W - 750 lm	6V/1,6Ah NiCd	
LED, 1h, 230V AC - maintained-/Non-maintained mode	XGMU013SC *	3 h	40 W - 750 lm	6V/4Ah NiCd	
LED, 3h, 230V AC - Non-maintained mode	XGMU003SC-BS *	3 h	9,2 W - 750 lm	6V/4Ah NiCd	
LUMINAIRES FOR CENTRAL BATTERY SYSTEMS AC/DC					
LED, 230V AC/DC	XGMU009 *	CPS	20 W - 2400 lm		
LED, 230V AC/DC	XGMU019 *	CPS	40 W - 4600 lm		
LUMINAIRES FOR CENTRAL BATTERY SYSTEMS AC/DC INCL. MONITORING MODULE					
LED, 230V AC/DC	XGMU009ML *	CPS	20 W - 2400 lm		
LED, 230V AC/DC	XGMU019ML *	CPS	40 W - 4600 lm		

*) only on request

XM (POLYCARBONATE CYLINDER)



SELF-CONTAINED LUMINAIRES WITH SELFCONTROL MODULE					
LED, 1h, 230V AC - Non-maintained mode	XPMU001SC-BS *	1 h	5,8 W - 700 lm	6V/1,6Ah NiCd	
LED, 1h, 230V AC - maintained-/Non-maintained mode	XPMU011SC *	1 h	40 W - 750 lm	6V/1,6Ah NiCd	
LED, 3h, 230V AC - Non-maintained mode	XPMU003SC-BS *	3 h	9,2 W - 750 lm	6V/4Ah NiCd	
LED, 3h, 230V AC - maintained-/Non-maintained mode	XPMU013SC *	3 h	40 W - 750 lm	6V/4Ah NiCd	
LUMINAIRES FOR CENTRAL BATTERY SYSTEMS AC/DC					
LED, 230V AC/DC	XPMU009 *	CPS	20 W - 2400 lm		
LED, 230V AC/DC	XPMU019 *	CPS	40 W - 4600 lm		
LUMINAIRES FOR CENTRAL BATTERY SYSTEMS AC/DC INCL. MONITORING MODULE					
LED, 230V AC/DC	XPMU009ML *	CPS	20 W - 2400 lm		
LED, 230V AC/DC	XPMU019ML	CPS	40 W - 4600 lm		

*) only on request

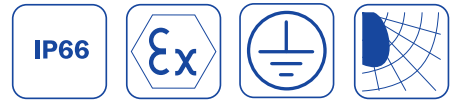

XX (GLASS CYLINDER)



SELF-CONTAINED LUMINAIRES WITH SELFCONTROL MODULE	
LED, 1h, 230V AC - maintained-/Non-maintained mode	XGXU011SC * 1 h 45 W - 750 lm 6V/1,5Ah NiCd
LED, 3h, 230V AC - maintained-/Non-maintained mode	XGXU013SC * 3 h 45 W - 750 lm 6V/4Ah NiCd
LUMINAIRES FOR CENTRAL BATTERY SYSTEMS AC/DC	
LED, 230V AC/DC	XGXU009 * CPS 40 W - 4600 lm
LUMINAIRES FOR CENTRAL BATTERY SYSTEMS AC/DC INCL. MONITORING MODULE	
LED, 230V AC/DC	XGXU009ML * CPS 40 W - 4600 lm

*) only on request

XX (POLYCARBONATE CYLINDER)



SELF-CONTAINED LUMINAIRES WITH SELFCONTROL MODULE	
LED, 1h, 230V AC - maintained-/Non-maintained mode	XPXU011SC * 1 h 45 W - 750 lm 6V/1,5Ah NiCd
LED, 3h, 230V AC - maintained-/Non-maintained mode	XPXU013SC * 3 h 45 W - 750 lm 6V/4Ah NiCd
LUMINAIRES FOR CENTRAL BATTERY SYSTEMS AC/DC	
LED, 230V AC/DC	XPXU009 * CPS 40 W - 4600 lm
LUMINAIRES FOR CENTRAL BATTERY SYSTEMS AC/DC INCL. MONITORING MODULE	
LED, 230V AC/DC	XPXU009ML CPS 40 W - 4600 lm

*) only on request

ACCESSORIES



4-fold pictograph set
Viewing distance 14m.

X4N

Art.-No. X4N



Chain eyes
Art.-No. X-KO001

X-KO001



Mounting brackets for wall/ceiling mounting
Art.-No. X-MB001





X-MB001







Metal cable gland with strain relief

EXPLOSION PROOF LUMINAIRES





Distance table XGIU003SC for plane emergency routes

Mounting height (m)					
2.00	4.04	9.73	9.58	9.44	3.94
2.50	4.44	10.79	10.66	10.52	4.33
3.00	4.75	11.72	11.58	11.43	4.64
3.50	4.98	12.52	12.37	12.21	4.89
4.00	5.14	13.17	13.01	12.86	5.08

Distance table XGMU013SC for plane emergency routes

Mounting height (m)					
2.00	4.60	11.40	10.34	9.30	3.89
2.50	5.50	13.65	12.44	11.22	4.68
3.00	5.88	14.65	13.47	12.26	5.07
3.50	6.21	15.51	14.36	13.16	5.42
4.00	6.46	16.29	15.14	13.92	5.72

Distance table XGXU013SC for plane emergency routes

Mounting height (m)					
2.00	5.18	12.92	11.70	10.49	4.35
2.50	5.89	14.84	13.48	12.12	5.01
3.00	6.22	15.84	14.48	13.14	5.38
3.50	6.52	16.62	15.29	14.02	5.69
4.00	6.76	17.28	16.05	14.82	5.96

The distance table is based on the following parameters: Maintenance factor: 0.8; emergency lighting factor 1.00; Minimum illumination on the center line: 1.00 lux; Minimum illumination on the half width of the rescue route: 0.50 lux, uniformity on the midline maximum 40:1; Width of the rescue route 2.00m

The luminaire distances for luminaires with polycarbonate cylinders is approx. 10-15% smaller than the distances specified in these tables for luminaires with glass cylinders.



Dimensions XI

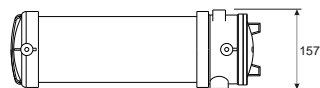

Dimensions XM

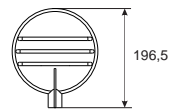
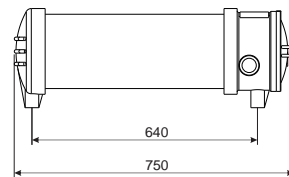
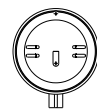
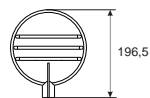
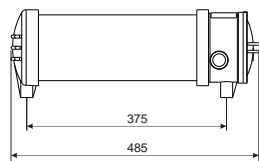

Dimensions XX

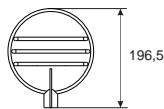
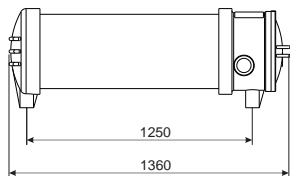
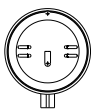
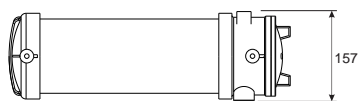



 **SKS / SGS**
EMERGENCY FLOODLIGHT



FACTS

- Steelsheet housing
- IP54
- Wall mounting
- -5°C to +40°C

Emergency floodlight in a non-maintained circuit for lighting spaces or emergency routes with pre-mounted or externally mountable floodlights, for fixed location or transportable. Remote monitoring via Wireless Professional is possible. Technical specifications with deep discharge protection and integrated lock against switching back on, limit switch, IC technology.

With maintenance free, long-life, gas-proof, Pb rechargeable batteries, electronic construction with switching option as well as LED function monitoring indicator.







SELF-CONTAINED LUMINAIRES WITH SELFCONTROL MODULE					
LED Emergency floodlight, 230V AC	SKS2101SC	1 h	2 x 900 lm	AGM Battery 12V 9Ah	
LED Emergency floodlight, 230V AC	SKS2103SC	3 h	2 x 900 lm	AGM Battery 12V 9Ah	
LED Emergency floodlight, 230V AC	SKS2108SC	8 h	2 x 900 lm	AGM Battery 12V 17Ah	
LED Emergency floodlight, 230V AC	SKS2301SC	1 h	2 x 2500 lm	AGM Battery 12V 17Ah	
LED Emergency floodlight, 230V AC	SGS2303SC	3 h	2 x 2500 lm	AGM Battery 12V 28Ah	
LED Emergency floodlight, 230V AC	SGS1308SC	8 h	2 x 900 lm	AGM Battery 12V 28Ah	
LED Emergency floodlight, 230V AC	SGS2501SC	1 h	2 x 4100 lm	AGM Battery 12V 28Ah	
LED Emergency floodlight, 230V AC	SGS2503SC	3 h	2 x 4100 lm	AGM Battery 12V 40Ah	
SELF-CONTAINED LUMINAIRES WITH WIRELESS PROFESSIONAL MODUL (NOT SWITCHABLE)					
LED Emergency floodlight, 230V AC	SKS2101WL	1 h	2 x 900 lm	AGM Battery 12V 9Ah	
LED Emergency floodlight, 230V AC	SKS2103WL	3 h	2 x 900 lm	AGM Battery 12V 9Ah	
LED Emergency floodlight, 230V AC	SKS2108WL	8 h	2 x 900 lm	AGM Battery 12V 17Ah	
LED Emergency floodlight, 230V AC	SKS2301WL	1 h	2 x 2500 lm	AGM Battery 12V 17Ah	
LED Emergency floodlight, 230V AC	SGS2303WL	3 h	2 x 2500 lm	AGM Battery 12V 28Ah	
LED Emergency floodlight, 230V AC	SGS1308WL	8 h	2 x 900 lm	AGM Battery 12V 28Ah	
LED Emergency floodlight, 230V AC	SGS2501WL	1 h	2 x 4100 lm	AGM Battery 12V 28Ah	
LED Emergency floodlight, 230V AC	SGS2503WL	3 h	2 x 4100 lm	AGM Battery 12V 40Ah	



Note: Versions with 30 / 50W LED floodlight don't have lights mounted on the housing. The illuminants have to be mounted separately within max. 1m distance.

EMERGENCY FLOODLIGHT

Distance table SKS2101 for plane emergency routes. The luminaire distances are measured with the theoretical ceiling mount of the luminaire.

Mounting height (m)					
2,00	3,46	6,91	8,26	9,16	4,29
2,50	4,16	8,64	10,33	11,45	5,13
3,00	4,80	10,07	11,82	13,14	5,64
3,50	5,39	11,38	13,10	14,48	6,06
4,00	5,93	12,58	14,16	15,57	6,40
5,00	6,64	14,74	16,26	17,44	7,14
6,00	7,40	16,62	18,10	18,96	7,40
7,00	7,78	18,28	19,62	20,22	7,78
7,50	7,77	19,02	20,25	20,73	7,77
8,00	7,72	19,74	20,80	21,14	7,72
9,00	7,56	20,67	21,78	21,87	7,56
10,00	7,28	21,36	22,16	22,16	7,28
10,50	7,08	21,51	22,20	22,23	7,08
12,00	6,93	21,72	22,02	22,08	6,39
14,00	6,52	20,80	21,16	21,24	4,84
16,00	0,84	19,84	20,00	19,80	0,56

Distance table SGS1308 for plane emergency routes. The luminaire distances are measured with the theoretical ceiling mount of the luminaire.

Mounting height (m)					
2,00	4,10	9,23	9,47	10,09	4,29
2,50	5,13	11,54	11,84	12,61	5,36
3,00	6,15	13,85	14,21	15,13	6,43
3,50	7,18	16,16	16,57	17,66	7,51
4,00	8,20	18,47	18,94	20,18	8,58
5,00	9,40	22,60	23,04	24,34	10,26
6,00	10,82	25,68	25,80	26,70	10,82
7,00	11,20	27,94	28,00	28,72	11,64
7,50	11,55	28,98	29,01	29,61	12,00
8,00	11,86	29,96	29,98	30,48	12,32
9,00	12,39	31,77	31,74	32,04	12,84
10,00	12,80	33,20	33,16	33,40	13,28
10,50	12,96	33,78	33,75	34,02	13,44
12,00	13,32	35,34	35,37	35,67	13,80
14,00	13,52	36,92	37,00	37,36	14,00
16,00	13,44	38,08	38,20	38,60	13,92



Distance table SGS2501 / SGS2503 for plane emergency routes. The luminaire distances are measured with the theoretical ceiling mount of the luminaire.

Mounting height (m)					
2,00	3,76	8,20	8,60	9,15	4,10
2,50	4,70	10,25	10,74	11,43	5,13
3,00	5,64	12,30	12,89	13,72	6,15
3,50	6,58	14,36	15,04	16,01	7,18
4,00	7,52	16,40	17,20	18,30	8,20
5,00	9,40	20,50	21,48	22,86	10,26
6,00	11,28	24,60	25,79	27,44	12,30
7,00	12,62	28,08	29,14	31,02	13,16
7,50	12,99	29,58	30,51	32,49	13,53
8,00	13,85	31,04	31,80	33,69	13,85
9,00	14,40	33,78	34,26	35,70	14,40
10,00	14,85	36,33	36,49	37,49	15,40
10,50	15,00	37,53	37,56	38,34	15,57
12,00	15,92	40,48	40,18	40,64	16,52
14,00	16,67	43,05	42,69	43,20	17,29
16,00	16,56	45,04	44,72	45,30	17,76

The distance table is based on the following parameters: Maintenance factor: 0.8; emergency lighting factor 1.00; Minimum illumination on the center line: 1.00 lux; Minimum illumination on the half width of the rescue route: 0.50 lux, uniformity on the midline maximum 40:1; Width of the rescue route 2.00m

For a light calculation adapted to the particular mounting situation and alignment of the spotlights, please use a software for the light calculation and the provided LDT files.

WALL MOUNTING

Dimensions SKS 9Ah, 17Ah

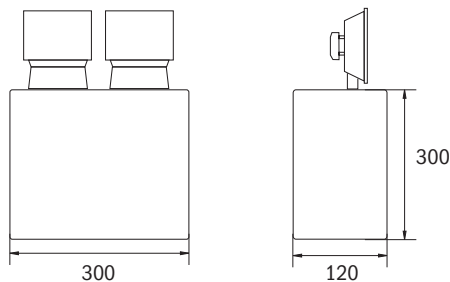

Dimensions SGS 28Ah, 40Ah

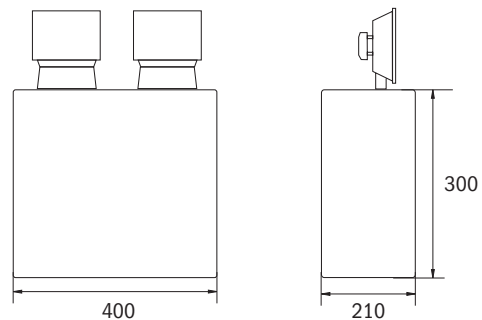

All Dimensions in mm



 **HX**
HANDHELD SPOTLIGHT



IP54



230V AC
12V AC

FACTS

- Polycarbonate, impact-resistant, black
- IP54
- 3 Watt Power-LED, white
- Li-ion battery maintenance-free 7,4V
- Charging time max. 6 hrs.
- Operating time at 100% luminosity: 5 hrs at 25% luminosity: 10 hrs
- Charging voltage: 230V AC or 12V DC
- Weight: 655g

Rechargeable Signal Lamp with 3W Power-LED and magnetic socket for professional use.

Upon mains failure the emergency function turns the light on automatically. Swiveling Lamp head with tilt angle 70° slew forward and 110° backward. Including flashing as well as dimmed mode for longer operation time. Wall bracket with charger function (230V supply).



SELF-CONTAINED LUMINAIRES			
LED 230V AC, 4h	HX	3 h - 180 lm	Li-Ion, 7,4V

Dimensions

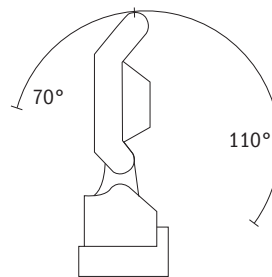
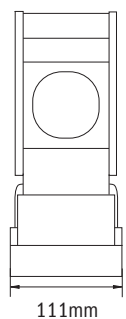
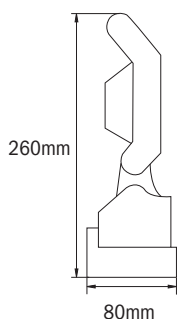

All Dimensions in mm



Distance to the handheld spotlight	luminosity (un-dimmed)
1m	5100 lux
2m	1100 lux
3m	525 lux
4m	415 lux
5m	320 lux
10m	100 lux

ACCESSORIES

HXNT12: 12V Car adaptor / Charging Cable

HXOSD: Clip-on diffusor, orange

HXACC: Replacement battery Li-ion 7.4V / 2200 mAh



 **GENERAL-PURPOSE LIGHTING
FOR SAFETY USE**





QAW

GENERAL PURPOSE AND EMERGENCY LIGHTING

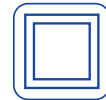

FACTS

- Metal housing with PMMA Cover
- IP20
- Wall or ceiling mounting
- Self-Contained: -5° to +40°C
Central battery: -20° to +40°C

Round metal luminaire for general lighting and the lighting of escape and rescue routes according to DIN EN 60598-1, DIN EN 60598-2-22 and EN 1838.

In mains operation the luminaire works with 26W / 2.300lm LED. Available for central power systems or as a self-contained emergency luminaire - on request with motion sensor.

All QAW luminaires are equipped with a neutral white (4,000 K) illuminant.

SELF-CONTAINED LUMINAIRES WITH SELFCONTROL MODULE		(lm in battery operation)			
LED, 1h, 230V AC	QAW421SC *	QAW421SC-SI*	1 h	29,7 W - 250 lm	3,2V/3,3Ah LiFePO4
LED, 3h, 230V AC	QAW403SC *	QAW403SC-SI*	3 h	30 W - 360 lm	3,2V/4,5Ah LiFePO4
LED, 3h, 230V AC	QAW423SC *	QAW423SC-SI*	3 h	29,7 W - 250 lm	3,2V/3,3Ah LiFePO4
LED, 8h, 230V AC	QAW428SC *	QAW428SC-SI*	8 h	29,7 W - 125 lm	3,2V/3,3Ah LiFePO4
SELF-CONTAINED LUMINAIRES WITH WIRELESS PROFESSIONAL MODUL		(lm in battery operation)			
LED, 1h, 230V AC	QAW421WL *	QAW421WL-SI*	1 h	30 W - 250 lm	3,2V/3,3Ah LiFePO4
LED, 3h, 230V AC	QAW423WL *	QAW423WL-SI*	3 h	30 W - 250 lm	3,2V/3,3Ah LiFePO4
LED, 8h, 230V AC	QAW428WL *	QAW428WL-SI*	8 h	30 W - 125 lm	3,2V/3,3Ah LiFePO4
LUMINAIRES FOR CENTRAL BATTERY SYSTEMS AC/DC		(lm in battery operation)			
LED, 230V AC/DC	QAW009 *	QAW009-SI*	CPS	26 W - 2300 lm	
LUMINAIRES FOR CENTRAL BATTERY SYSTEMS AC/DC INCL. MONITORING MODULE		(lm in battery operation)			
LED, 230V AC/DC	QAW009ML *	QAW009ML-SI*	CPS	26 W - 2300 lm	
LED, 230V AC/DC	QAW029ML *	QAW029ML-SI*	CPS	30,6 W - 360 lm	

* Also available with an integrated **HF motion sensor**. It switches the luminaire only in mains operation. Add -BM at the end of the order number.

WALL- ODER CEILING MOUNTING

Dimensions QAW

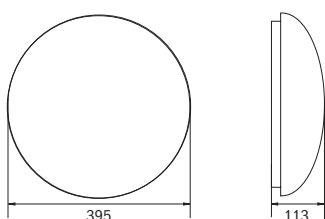

All Dimensions in mm



QBW

GENERAL PURPOSE AND EMERGENCY LIGHTING

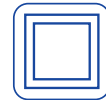

FACTS

- Plastic housing, white
- IP44
- 17W LED with 1.800lm luminous flux in mains mode
- SelfContained: -5° to +40°C
Central battery: -20° to +40°C

Round plastic luminaire for general lighting and illumination of escape and rescue routes according to DIN EN 60598-1, DIN EN 60598-2-22 and DIN EN 1838.

All QBW luminaires are equipped with a neutral white (4,000 K) illuminant.

Robust and timeless design, suitable for indoor use. The emergency light LED can be unfolded tool-free during assembly e.g. for optimally illumination of the escape and rescue routes especially for wall mounting.

SELF-CONTAINED LUMINAIRES WITH SELFCONTROL MODULE		(lm in battery operation)			
LED, 1h, 230V AC	QBW421SC	1 h		19 W - 470 lm, 6,4V/1,2Ah LiFePO4	
LED, 3h, 230V AC	QBW423SC	3 h		19 W - 255 lm, 6,4V/3,3Ah LiFePO4	
SELF-CONTAINED LUMINAIRES WITH WIRELESS PROFESSIONAL MODUL		(lm in battery operation)			
LED, 1h, 230V AC	QBW421WL	1 h		19 W - 470 lm, 6,4V/1,2Ah LiFePO4	
LED, 3h, 230V AC	QBW423WL	3 h		19 W - 255 lm, 6,4V/3,3Ah LiFePO4	
LUMINAIRES FOR CENTRAL BATTERY SYSTEMS AC/DC					
LED, 230V AC/DC	QBW009	CPS		17 W - 1800 lm	
LUMINAIRES FOR CENTRAL BATTERY SYSTEMS AC/DC INCL. MONITORING MODULE					
LED, 230V AC/DC	QBW009ML	CPS		19 W - 1800 lm	
LED, 230V AC/DC	QBW029ML	CPS		19 W - 470 lm	

WALL- ODER CEILING MOUNTING

Dimensions QBW

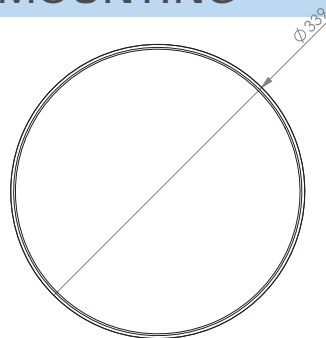
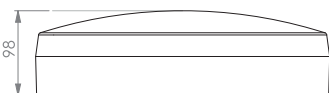

All Dimensions in mm

Distance table QBW009 for plane emergency routes

Mounting height (m)					
2.00	4.63	11.32	11.28	11.23	4.60
2.50	5.79	14.15	14.10	14.04	5.75
3.00	6.95	16.99	16.92	16.85	6.90
3.50	7.71	18.90	18.82	18.75	7.66
4.00	8.13	20.00	19.92	19.85	8.07



QCW

GENERAL PURPOSE AND EMERGENCY LIGHTING



FACTS

- Zinc die-cast housing, white or anthracite
- IP54
- 17W LED with 1.600lm luminous flux in mains mode
- Self-Contained: -5° to +40°C
Central battery: -20° to +40°

Round die-cast aluminum luminaire for general lighting and illumination of escape and rescue routes according to DIN EN 60598-1, DIN EN 60598-2-22 and DIN EN 1838.

Robust and timeless design, suitable for indoor and outdoor use. The emergency light LED can be unfolded tool-free during assembly e.g. for optimally illumination of the escape and rescue routes especially for wall mounting.

All QCW luminaires are equipped with a neutral white (4,000 K) illuminant.

SELF-CONTAINED LUMINAIRES WITH SELFCONTROL MODULE (lm in battery operation)				
LED, 1h, 230V AC	QCW421SC	QCW421SC-AZ	1 h	19 W - 470 lm, 6,4V/1,2Ah LiFePO4
LED, 3h, 230V AC	QCW423SC	QCW423SC-AZ	3 h	19 W - 255 lm, 6,4V/1,2Ah LiFePO4
SELF-CONTAINED LUMINAIRES WITH WIRELESS PROFESSIONAL MODUL (lm in battery operation)				
LED, 1h, 230V AC	QCW421WL	QCW421WL-AZ	1 h	19 W - 470 lm, 6,4V/1,2Ah LiFePO4
LED, 3h, 230V AC	QCW423WL	QCW423WL-AZ	3 h	19 W - 255 lm, 6,4V/1,2Ah LiFePO4
LUMINAIRES FOR CENTRAL BATTERY SYSTEMS AC/DC (lm in battery operation)				
LED, 230V AC/DC	QCW009	QCW009-AZ	CPS	17 W - 1600 lm
LUMINAIRES FOR CENTRAL BATTERY SYSTEMS AC/DC INCL. MONITORING MODULE (lm in battery operation)				
LED, 230V AC/DC	QCW029ML	QCW029ML-AZ	CPS	19 W - 470 lm



All self-contained luminaires are optionally available with a new LiFePO4 battery, which enables use at temperatures from -15°C to +40°C. The article number is supplemented by the suffix -TT.

WALL- OR CEILING MOUNTING

Dimensions QCW

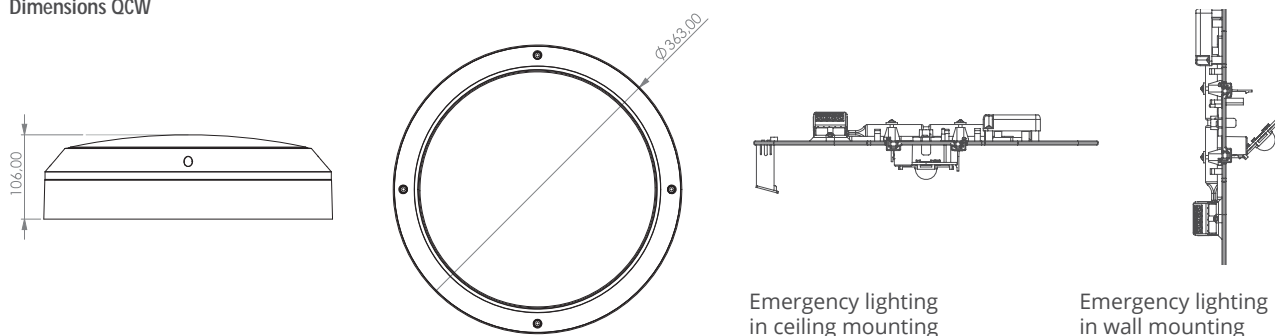

All Dimensions in mm

Distance table QCW009 for plane emergency routes

Mounting height (m)					
2.00	4.47	10.86	10.75	10.65	4.40
2.50	5.59	13.57	13.44	13.31	5.50
3.00	6.71	16.29	16.13	15.98	6.60
3.50	7.52	18.30	18.13	17.96	7.40
4.00	7.94	19.42	19.25	19.09	7.82



LFD

GENERAL PURPOSE AND EMERGENCY LIGHTING



FACTS

- Glass fiber reinforced polyester, grey
- Acrylic glass prismatic transparent
- IP65
- Wall or ceiling mounting
- -5°C to +40°C

Combined LED general and emergency luminaire for illuminating escape and rescue routes according to DIN EN 60598-1, DIN EN 60598-2-22 and DIN EN 1838.

The robust LED wall and ceiling luminaire made of glass fiber reinforced polyester for wet room applications is suitable for illuminating storage areas, car parks etc. In mains operation, the luminaire provides up to 7.000lm. External mounting brackets facilitate installation.

SELF-CONTAINED LUMINAIRES WITH SELFCONTROL MODULE					
LED, 3h, 230V AC	LFD12003SC-NW	3 h		40 W - 500 lm	3,2V/4,5Ah LiFeP04
LED, 3h, 230V AC	LFD15003SC-NW	3 h		55 W - 500 lm	3,2V/4,5Ah LiFeP04
LUMINAIRES FOR CENTRAL BATTERY SYSTEMS AC/DC					
LED, 230V AC/DC	LFD12009-NW	CPS		36 W - 4500 lm	
LED, 230V AC/DC	LFD15009-NW	CPS		54 W - 7000 lm	
LUMINAIRES FOR CENTRAL BATTERY SYSTEMS AC/DC INCL. MONITORING MODULE					
LED, 230V AC/DC	LFD12009ML-NW	CPS		38 W - 4500 lm	
LED, 230V AC/DC	LFD15009ML-NW	CPS		56 W - 7000 lm	

Versions with 1h und 8h in development.

WALL- OR CEILING MOUNTING

Dimensions LFD

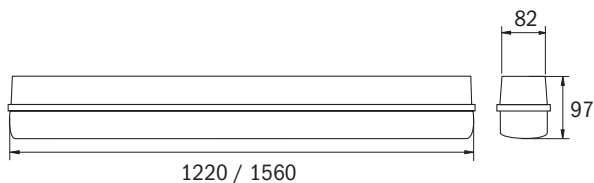

All Dimensions in mm

Distance table LFD15003SC for plane emergency routes (additional distance tables on our website)

Mounting height (m)					
2.00	4.32	10.66	10.16	9.66	4.00
2.50	4.70	11.68	11.16	10.64	4.35
3.00	4.99	12.54	12.01	11.47	4.64
3.50	5.23	13.27	12.72	12.17	4.86
4.00	5.40	13.89	13.34	12.78	5.04



 **FLU**
EMERGENCY ROUTE LIGHTING



FACTS

- Zinc die-cast housing
- LED mit 10W, 30W or 50W
- IP66
- -25°C to +40°C
- Connection cable: 160 cm

Robust ceiling-mounted Aluminium die-cast luminaire for the lighting of escape and rescue routes according to DIN EN 60598-1, DIN EN 605982-22 and EN 1838.

The IP66 flood light is suitable for indoor and outdoor use. Due to the wide beam angle, large areas can be easily illuminated. The MU05 monitoring module is installed in the supplied separate housing.



LUMINAIRES FOR CENTRAL BATTERY SYSTEMS AC/DC INCL. MONITORING MODULE

10W, 230V AC/DC	FLU10ML	CPS	11,5 W - 1400 lm	
30W, 230V AC/DC	FLU30ML	CPS	31,5 W - 4200 lm	
50W, 230V AC/DC	FLU50ML	CPS	51,5 W - 7000 lm	

WALL- OR CEILING MOUNTING

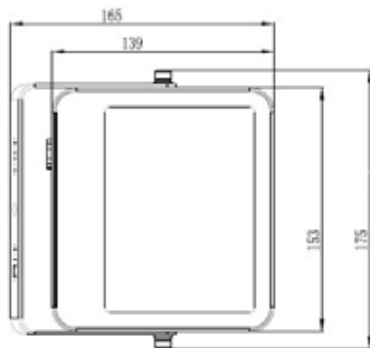

FLU10ML

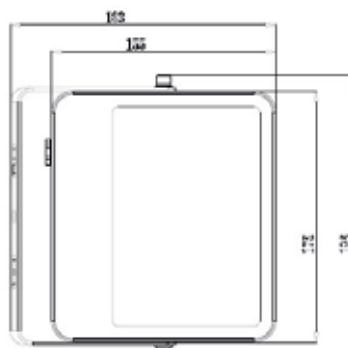

FLU30ML

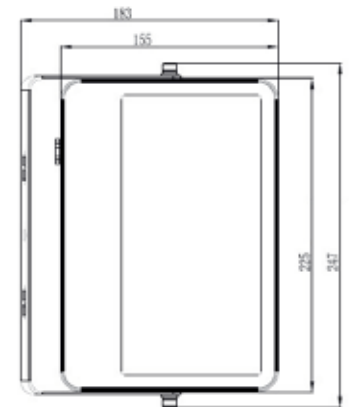

FLU50ML

All Dimensions in mm

ACCESSORIES



Dimensions MU06-BOX

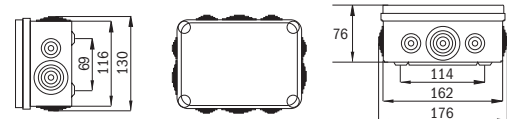

» WIRELESS BASIC & LIGHTLINX®

CONTROL AND MONITOR EMERGENCY LIGHTS COMFORTABLE BY APP



Wireless Basic® connects up to 50(*) self-contained luminaires in a small emergency lighting system via Bluetooth Low Energy (BLE) to your Android Smartphone or Tablet. The luminaires communicate via BLE with each other and build a closed, safe Bluetooth Mesh Network. Each exit sign or emergency luminaire equipped with a **Wireless Basic®** module will report its current status and the results of the legally required regular tests to the Bluetooth-requesting mobile device. In addition, the results of the tests will be stored safely in the cloud based RP-Onlineportal LIGHTLINX® (www.Lightlinx.com).

The installation of the luminaires is done quick and easy, because there are no additional wires needed thanks to the Bluetooth radio modules.

In the **Wireless Basic®** app luminaires can be grouped and assigned to projects. The lights can also be switched or a test triggered via the Bluetooth interface.

As with the Wireless Professional, the individual luminaires also communicate with each other during the **Wireless Basic®** monitoring, thus increasing the range of the Bluetooth signal. If a mobile device is within range of a luminaire of a system, the data of all associated luminaires can be transmitted. This minimizes testing effort.

The wireless connection of the **Wireless Basic®** luminaires via BLE offers several advantages for smaller emergency lighting systems with up to 50 individual luminaires: minimal installation and maintenance effort, omission of a central control unit, cost-effective monitoring via app, secure storage of data and test protocols in the cloud.

In the current version, the app offers a central, noticeable display version of the current status to meet the pre-standard VDE V0108-100-1: 2018-12. The central mode ensures that the status of all luminaires registered in the network is displayed on a device that remains at the installation site.

The Wireless Basic App is available for download at Google Play store or Apple App store.

* - Depending on the country of installation, further restrictions may be imposed by local regulations.

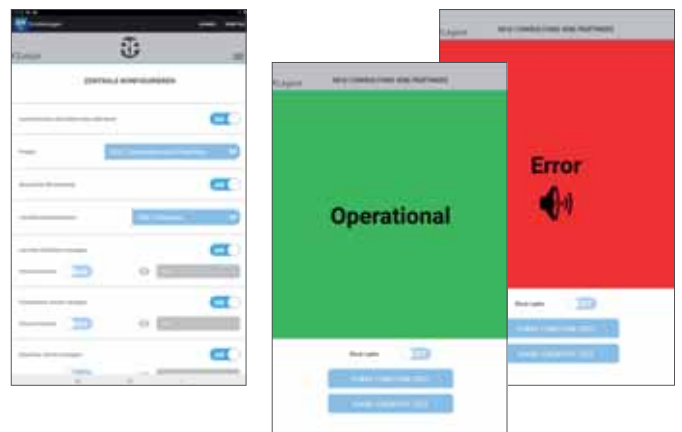

The central mode of the Wireless Basic App fulfills the Pre-standard VDE V0108-100-1: 2018-12

LIGHTLINX® 1 Error , 0 Warning , 1 Info

Startseite | Ordner und Projekte verwalten | APITest Techniken | Abmelden | Deutsch

Alle

Projekte nach Status filtern: Alle Ok Info Warnung Fehler

Status	Projektname	Projektzahl	Stadt	Zuletzt aktualisiert	Typ
●	Demo Projekt	63110	Rodgau	24.01.2020, 16:57:34	WirelessBasic
●	Freies Project 1	63110	Rodgau	24.01.2020, 16:57:34	WirelessBasic
●	Freies Project 2	63110	Rodgau	24.01.2020, 16:57:34	WirelessBasic
●	Freies Project 3	63110	Rodgau	24.01.2020, 16:57:34	WirelessBasic
●	Test Project	63110	Rodgau	24.01.2020, 16:57:34	WirelessBasic
●	Test Project II	23446	Rodgau	24.01.2020, 16:57:34	WirelessBasic

The **Lightlinx®** Cloud gives the operator of emergency lighting systems an overview of the various installed systems and their status.

In the event of a malfunction, it is possible to react quickly and efficiently to ensure the operation of the system.

Wireless Basic® is currently available for luminaires of the following types:

- ASMU
- EA
- IL
- KM
- KMB
- KS
- ZAW

Further luminaire types are in preparation.

» WIRELESS PROFESSIONAL

WIRELESS LUMINAIRE MONITORING

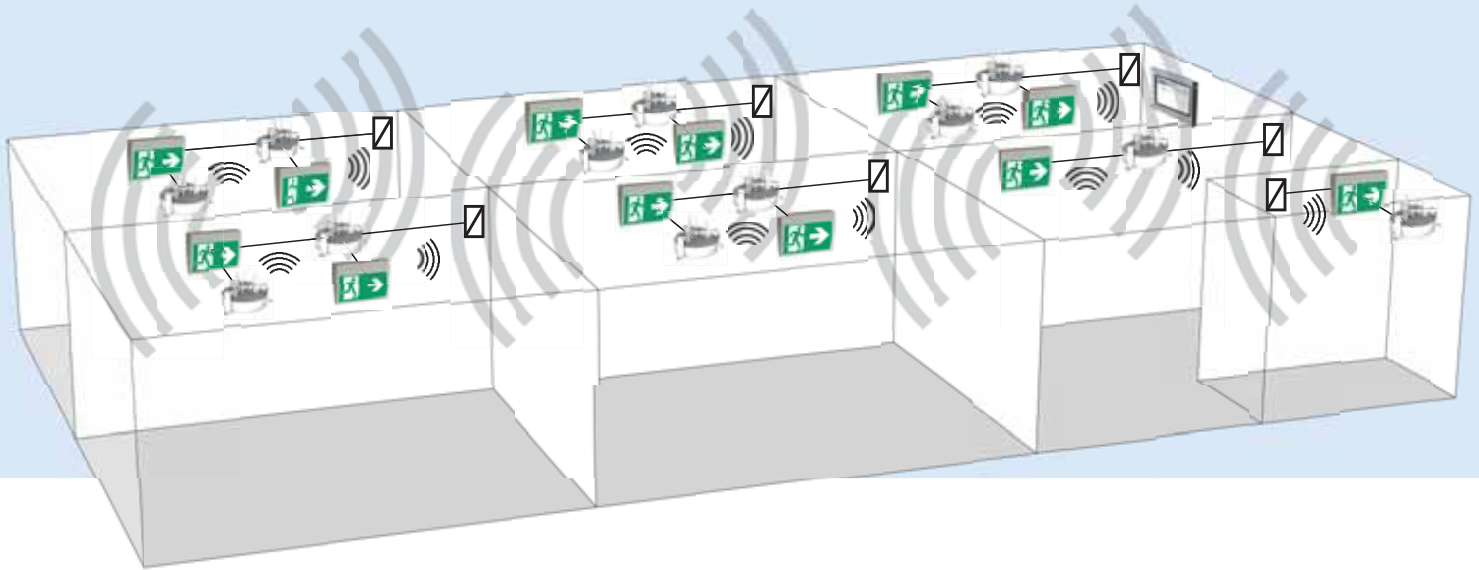

NEXT GENERATION LUMINAIRE MONITORING AND CONTROL

With the new Wireless Professional the control and monitoring of self-contained emergency and security lighting is a snap! To install the lights the only thing necessary is a connection to a normal power supply with 230V AC. The subsequent installation of the wireless system for monitoring and controlling the luminaires is taking care of itself.

Each luminaire equipped with wireless professional may connect to other luminaires or the central unit on the European approved frequency of 868 MHz and report its own and the status of others through the system registered luminaires. The indoor range sums up to at least 30m. Thanks to the radio frequency of 868 MHz even a reinforced concrete ceiling between floors is no insurmountable barrier.

The wireless system can include 1,000 devices (sum of all luminaires, repeater and I/O boxes connected to the system) per central. Furthermore timerfunctions and networked systems are possible by standard.

The radio system is organizing itself ad-hoc. Each Wireless Professional luminaire automatically contacts all reachable nodes: other luminaires, repeaters or the central control unit itself. By networking of several central units the 1,000 luminaire limit can be exceeded.

The software for the central unit is available in several languages, allows the storage of building maps and can be installed on an existing Windows system. The registered luminaires can be placed on the digital floor map and appear with their current status.

Many of the available Wireless Professional luminaires can be switched by radio. A timetable stored in the central unit makes it possible to put the emergency lights in an unused building at the weekend in standby mode. Thus, the Wireless Professional saves energy and even the security is guaranteed at all times.

Wireless Professional lights are very inconspicuous. Even in stainless steel or aluminum cases the radio technology works without any visible antennas.



WIRELESS PROFESSIONAL - ADVANTAGES AT A GLANCE

- Easy installation – only 230V AC needed
- Self-organizing ad-hoc wireless system
- Range between luminaires guaranteed 30m inside buildings (even through a concrete ceiling)
- Europe conform frequency of 868 MHz
- Up to 4 times higher range than 2.4 GHz-Systems
- Resistant to DECT, Bluetooth and WLAN signals
- 1000 devices per system
- Timerfunctions
- networking systems
- Multi-language easy to use software
- No visible antenna on the luminaires
- Many luminaires can be switched via timetable
- Status and error reports are delivered to the system via E-Mail administrator
- Log for daily/weekly function test stored in the central unit
- Capacity test (also in groups) of the battery for the whole operating time (usually 3h) possible
- Repeater for range extension
- Switching of luminaires between non-maintained and maintained mode by software
- No faulty connection – no BUS-line
- Polarised
- Monitoring system according to EN 62034 Type ER



WLZENT 03

The Wireless Professional control centre developed for industrial use is based on a Linux Embedded PC. The functional, service-friendly wall-mounted housing with touch screen can be installed directly at a permanently manned location. Thus, all functions and system information of your Wireless Professional installation are available at your fingertips.

Connection to the LIGHTLINX® Cloud is possible from Wireless Professional Software Version 3.0.

» WIRELESS PROFESSIONAL

WIRELESS LUMINAIRE MONITORING

WIRELESS PROFESSIONAL CENTRAL - AVAILABLE VERSIONS

Version	Order number	Scope of delivery
USB-Coordinator (1x needed per system)	WLKOR3	USB-Coordinator incl. Wireless Professional Software for connection to an existing Windows®-System;
Linux-Industrial-PC incl. WirelessProfessional Software	WLZENT03	Industrial-PC, Touchdisplay, incl. USB Koordinator und Wireless Professional Software
Repeater	WLREP1-IP20	Repeater for range extension in areas with bad reception, IP20 housing
Repeater	WLREP2-IP54	Repeater for range extension in areas with bad reception, IP54 housing
Wireless Embedded PC for 1000 Luminaires	WLCPC3	Wireless Professional Compact PC, DIN rail mounting 5TE Embedded, incl. WL Software, mains supply, USB-Coordinator (WLCPC3 can assign 1000 luminaires)
Wireless Embedded PC	WLCPC3.G	Wireless Professional Linux compact PC in wall housing IP65, Raspberry Pi 4 incl. WL software, coordinator + power supply, wired to terminal



Wireless Embedded PC

WIRELESS IO-BOX



FACTS

- 1 potential-free combined fault indication contact
- 2 potential-free programmable contacts
- 2 programmable galvanically isolated inputs
- Reverse polarity tolerant inputs
- Special fire alarm function integrated
- 24V DC auxiliary voltage output

Art.-No.: WLIO32

The IO-box is an interface module of the automatic test and control system for emergency lighting Wireless Professional, whose inputs and outputs signalise states and conditions of and to the test and control system. The IO-box has 3 outputs in form of potential-free changeover contacts, of which contact 1 is used for a system disturbance combined fault indication. The other two contacts can be programmed by means of the Wireless Professional software, in order to signalise various system states such as last test - failure, and operating status or switch single luminaires or groups. An LED is allocated to each output relay which signalises whether the relay is triggered.

Furthermore, there are 2 galvanically isolated switch inputs to integrate control and/or sensor signals of e.g. an external test pushbutton or a key switch. An LED is allocated to each input to signalize that a switch voltage is applied to it. The IO-box has an auxiliary voltage output which provides an auxiliary voltage that can be used to energize the inputs. The auxiliary voltage can be used as shown in the connection example.

The IO-box is designed for mounting on a hat rail in a switching cabinet. The information transfer from the IO-box to the Wireless Professional centre is wireless. IO Box is able to switch luminaires regardless of the central unit.

DIMENSIONS AND CONNECTION EXAMPLE

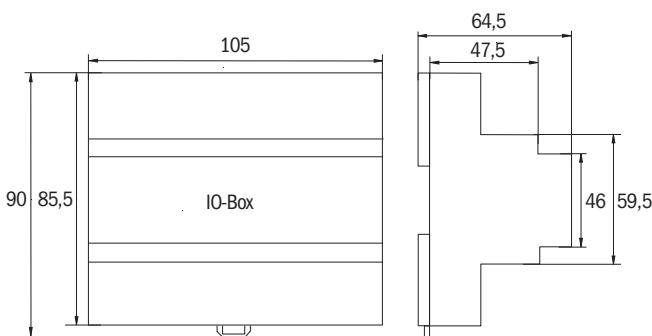

All Dimensions in mm

» ACCESSORIES

Name	1PW-EB	1PV-EB	2PW-EB	2PV-EB	2DW-EB	2DS-EB	DSA / DSA2 / DSA3 / DSA4
Colour	white	chrom	white	chrom	white	silver	silver
Standard length	50 cm	50 cm	50 cm	50 cm	50 cm	50 cm	1,5 m / 3m / 5m / 8m
Optional length	1 m / 2m	1 m / 2m	1 m / 2m	1 m / 2m	1 m / 2m	1 m / 2m	-
Material	Steel pipe	Steel pipe	Steel pipe	Steel pipe	Steel pipe	Steel pipe	Steel rope
Suitable for	WK, WG, WX,	WK, WG, WX,	LM, LX, LS, KB, KX, KS, KM, KC, KD, KL, KW, PF, KE	LM, LX, LS, KB, KX, KS, KM, KC, KD, KL, KW, PF, KE, AS	LM, LX, LS, KB, KX, KS, KM, KC, KD, KL, KW, PF, KE	LM, LX, LS, KB, KX, KS, KM, KC, KD, KL, KW, PF, KE	LM, LX, LS, KB, KX, KS, KM, KC, KD, KL, KW, PF, KE, AS

Pendulum / Cord suspension

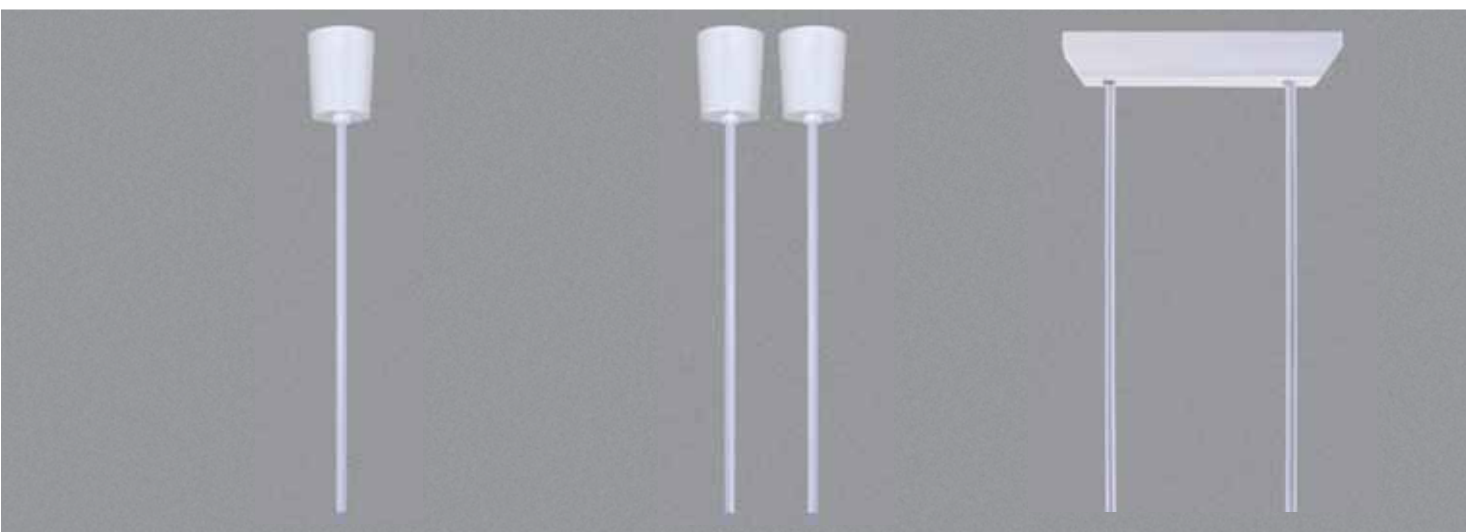

1PW

2PW

2DW /2DS

Wall bracket

Wall bracket



AWX



AWM suitable for:
KB, KWI, LX, GX, ASMU

AWKSU suitable for:
KS, KM, KT

» BALL PROTECTION

STEEL, POWDER COATED

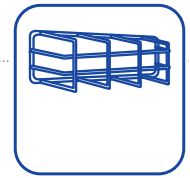

Suitable for luminaire types:
KD / KM / KS / LM / PM

Dimensions:
B x H x T 320 x 220 x 120 mm

Drilling distances:

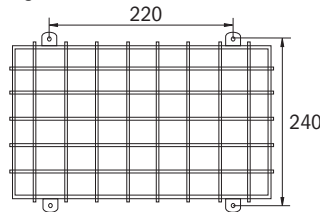

BALL1

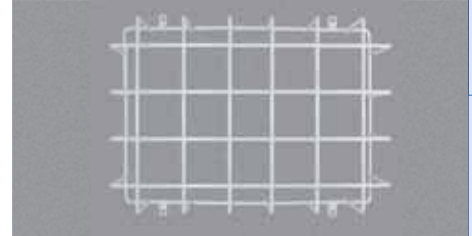

Suitable for luminaire types:
KC / KL / LX / PF

Dimensions:
B x H x T 450 x 280 x 125 mm

Drilling distances:

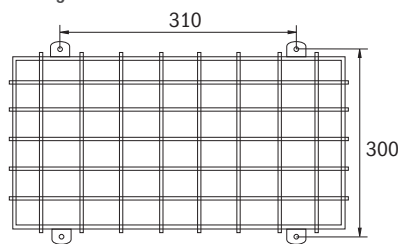

BALL2

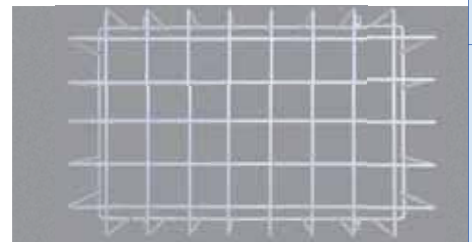

Suitable for luminaire types:
IL / EA

Dimensions:
B x H x T 200 x 200 x 80 mm

Drilling distances:

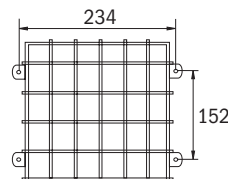

BALL3

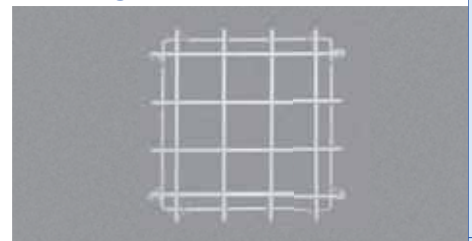

Suitable for luminaire types:
KW / KWI

Dimensions:
B x H x T 420 x 170 x 170 mm

Drilling distances:

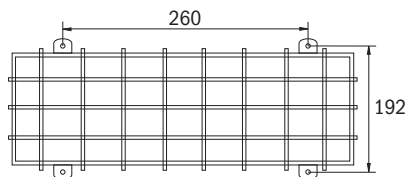

BKW

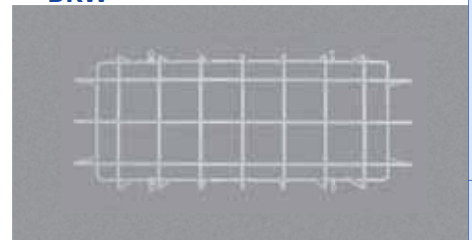



 **BALL PROTECTION**
POLYCARBONATE, TRANSPARENT

POLYCARBONATE BALL PROTECTION

290 x 210 x 77mm

Art.-No. BALLPLX-AM

Suitable for luminaires of types:
AM

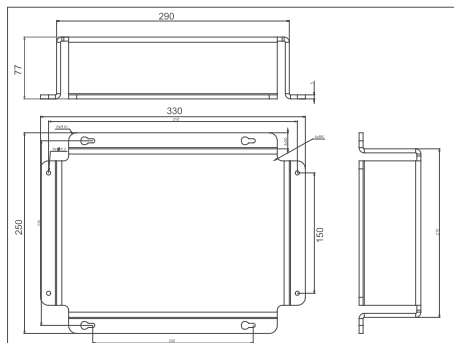

POLYCARBONATE BALL PROTECTION

390 x 250 x 88mm

Art.-No. BALLPLX-AX

Suitable for luminaires of types:
AX, KC

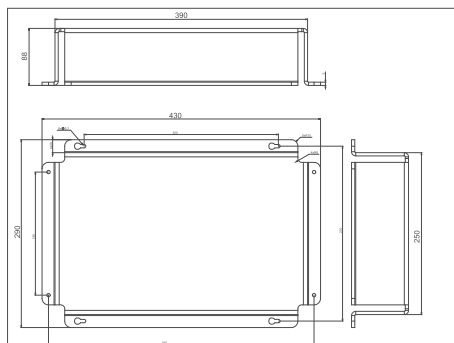

POLYCARBONATE BALL PROTECTION

370 x 140 x 77mm

Art.-No. BALLPLX-KBU

Suitable for luminaires of types:
KBU

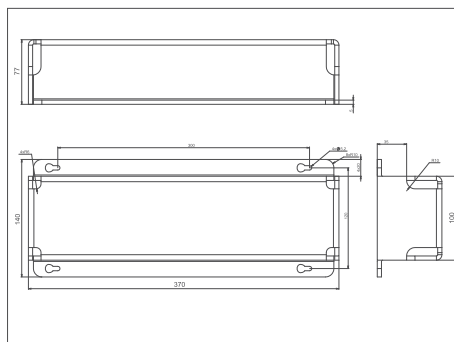

POLYCARBONATE BALL PROTECTION

370 x 282 x 77mm

Art.-No. BALLPLX-KBS

Suitable for luminaires of types:
KB incl. KBG (KBM / KBK)

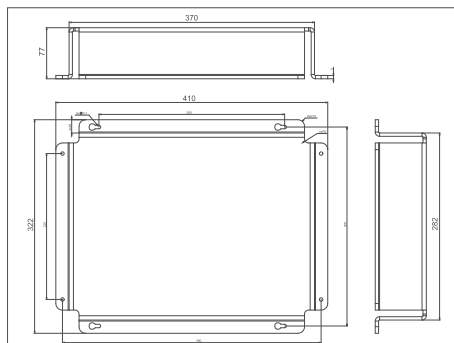

POLYCARBONATE BALL PROTECTION

415 x 171 x 31mm

Art.-No. BALLPLX-KBE

Suitable for luminaires of types:
KBU in Recessed frame KBE

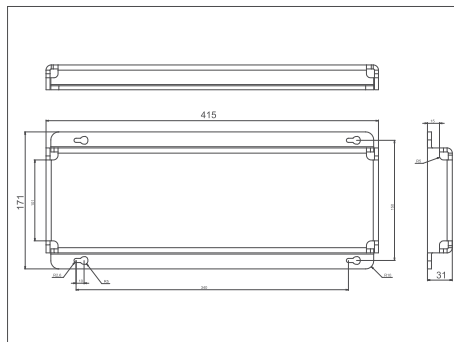

GENERAL
INFORMATIONS

DESIGN LUMINAIRES

DYNAMIC
LUMINAIRES

UNIVERSAL
LUMINAIRES

INDUSTRIAL
LUMINAIRES

GENERAL LIGHTING
WITH EMERGENCY LIGHT

WIRELESS MONITORING

ACCESSORIES

MODULES

» BALL PROTECTION

POLYCARBONATE, TRANSPARENT

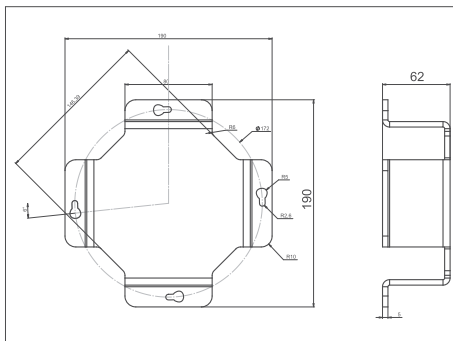

POLYCARBONATE BALL PROTECTION

190 x 190 x 62mm

Art.-No. BALLPLX-ILD

Suitable for luminaires of types:
ILDx
EAR / EAQ

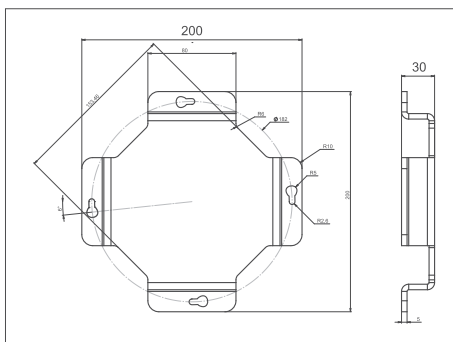

POLYCARBONATE BALL PROTECTION

200 x 200 x 30mm

Art.-No. BALLPLX-ILE

Suitable for luminaires of types:
ILEx
EE

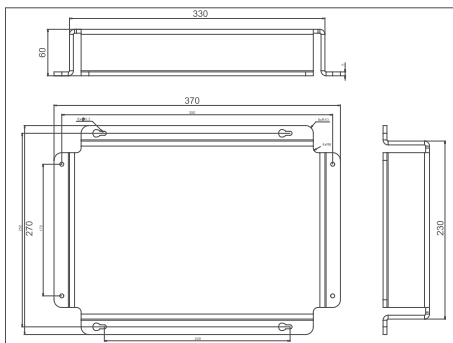

POLYCARBONATE BALL PROTECTION

330 x 230 x 60mm

Art.-No. BALLPLX-KMU

Suitable for luminaires of types:
KMU, KSU, KSC

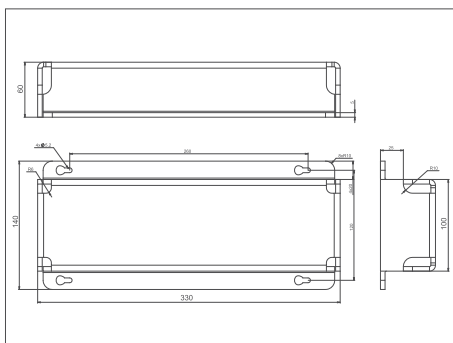

POLYCARBONATE BALL PROTECTION

330 x 100 x 60mm

Art.-No. BALLPLX-KMB

Suitable for luminaires of types:
KMB

POLYCARBONATE BALL PROTECTION

370 x 270 x 100mm

Art.-No. BALLPLX-KD

Suitable for luminaires of types:
KD

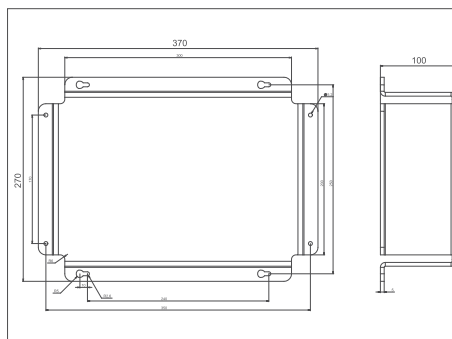

POLYCARBONATE BALL PROTECTION

413 x 183 x 112mm

Art.-No. BALLPLX-KWW

Suitable for luminaires of types:
KW, KWI

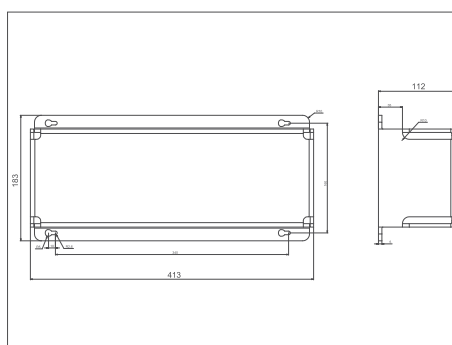

MOUNTING RECOMMENDATION

Stone or concrete wall: Dowel 8mm, Screw 5,5mm

Wood: Screw 5,5 x 35mm

» MLED 500 / NT24

EMERGENCY LIGHT MODULES CENTRAL BATTERY SYSTEMS



The **MLED500** is an electronic switching power supply with integrated individual light monitoring, light management function, mains monitoring, dimmer and flashing functions. All switching modes are possible. The mains monitor allows the operation of connected luminaires in non-maintained mode in a maintained circuit. In case of a mains failure all lights are switched on automatically. LED illuminants with a max. output of 8W can be used as consumers.

The MLED500 is also capable of dimming the lights to 30% or 50% in mains operation and to execute a flashing function in emergency operation.

The MLED500 is suitable for use with emergency lighting systems of the MC series.



NT24: Switch-mode power supply up to 5W for LED lights

Set-up of various output voltages (3.3V/5V/12V/24V) possible.

The NT24 power supply can be used in conjunction with a monitoring module for use in emergency light systems of the MC series. The respective output voltage is set via the switch.

SELF-CONTAINED EMERGENCY LIGHT MODULES

The **LPK** is a processor-controlled emergency lighting insert for self-powered lights with LED bulbs.

Designed for installation in lights and for connecting two LiFePO4 batteries via a battery manager (LPK-BMS). RP-LED bulbs can be supplied with 12V supply voltage.

The operating time can be selected between 1 and 3 hours, depending on the capacity of the battery.

The **LEM** is a self-contained emergency lighting module intended for use on LED lights with 1x1W ERT or 8 to 11-fold low power LED strips.

The technical configuration of the LEM complies with EN 60598-2-22 and DIN VDE 0108 (deep discharge protection, restart interlock and switch-over device). A functionality test is possible at any time with the

The **LEX** (LED supply module) is intended for use with LED lights with a max. 4W output (e.g. 12V LED disc or LED strip). The technical configuration of the LEX complies with requirements per DIN EN 60598-2-22 and DIN VDE 0108 (deep discharge protection, restart interlock and switch-over device).

WRLED...(-Box) for LED panels and downlights combines the electronics with an accumulator in the same housing for easy installation in confined spaces. Strain relief and wires led out make work easier for the installer. A microprocessor automatically adjusts the LED current to the connected luminaire and the battery used, thus providing maximum illuminance throughout the emergency operating period.

The **LEO** module is a processor-controlled emergency lighting insert as a single battery supply for LED consumers.

Intended for installation in emergency lights for use in combination with a Wireless Professional System.

The technical structure of the LPK complies with the regulations in accordance with EN 61347-1, 61347-2-7, 61347-13 and 62384. In addition, the LPK is equipped with a self-control (SC) function in accordance with DIN EN 62034.

externally connected test button (adhesive pad). A charge indicator LED is also integrated into this pad. This accurately displays the battery charge. Expandable with SELF-CONTROL, BUS-CONTROL and Wireless Professional.

The LED lights that are connected to the LEX can be operated as switched lights, maintained lights or as non-maintained lights. It is possible to operate the connected lights whilst dimmed in maintained operation via the integrated cinema switching. The light intensity here equates to approx. 12.5% of the standard light intensity.

During regular mains operation, the LED array is supplied by the LED driver. During emergency operation, the power is supplied by the rechargeable battery installed in the Emergency Box.

Suitable for RP LED lamps from 8V to 20V, max. 4W, in constant current or constant voltage control. Exclusively for LiFePO4 batteries 2x 3.2V from 600mAh to 6,000mAh





 **NVG**
SELF-CONTAINED POWER SUPPLY



IP54

Ausgang
230V/50Hz

FACTS

















- Steelsheet or PC housing
- IP54
- Wall mounting
- -5°C to +40°C

Emergency power supply with output voltage: 230V / AC by an inverter. 2-wire-system up to max. 500 m distance. Single and double supply luminaire with the available illuminants: florescent lamps, filament lamps and LED at 100% luminous flux.

Technical specifications according to DIN EN 60598-2-22. With deep discharge protection and integrated switch-on-lock, treshold switch. The Power is provided by maintenance-free long-life and gas-proof Pb rechargeable batteries. The full electronic and time guided charging extends the battery life. The operational state and fails are shown by the LED function monitor. It is possible to manually activate a test via the build in test switch (not on WL).



SELF-CONTAINED POWER SUPPLY

Order number	Housing	Dimensions	Output (inkl. 20% Reserve)			Ingress Protection	Protection class	Battery	
			1h	3h	8h				
SELF-CONTAINED SUPPLY INCL. SELF-CONTROL MODULE									
NVKS203SC	Steelsheet	120 x 300 x 300 mm	-	20 W	-	IP54	1	OGIV1290LP, AGM Battery 12V 9Ah	
NVKS403SC	Steelsheet	120 x 300 x 300 mm	-	40 W	-	IP54	1	OGIV12170LP, AGM Battery 12V 17Ah	
NVGS203SC	Steelsheet	210 x 400 x 500 mm	-	20 W	-	IP54	1	OGIV1290LP, AGM Battery 12V 9Ah	
NVGS403SC	Steelsheet	210 x 400 x 500 mm	-	40 W	-	IP54	1	OGIV12170LP, AGM Battery 12V 17Ah	
NVGS653SC	Steelsheet	210 x 400 x 500 mm	-	65 W	-	IP54	1	OGIV12280L, AGM Battery 12V 28Ah	
NVGS903SC	Steelsheet	210 x 400 x 500 mm	-	90 W	-	IP54	1	OGIV12400LP, AGM Battery 12V 40Ah	
SELF-CONTAINED SUPPLY WITH WIRELESS PROFESSIONAL MODULE									
NVGS451WL	Steelsheet	210 x 400 x 500 mm	45 W	-	-	IP54	1	OGIV1290LP, AGM Battery 12V 9Ah	
NVGS601WL	Steelsheet	210 x 400 x 500 mm	60 W	-	-	IP54	1	OGIV12170LP, AGM Battery 12V 17Ah	
NVGS1051WL	Steelsheet	210 x 400 x 500 mm	105 W	-	-	IP54	1	OGIV12170LP, AGM Battery 12V 17Ah	
NVGS1301WL	Steelsheet	210 x 400 x 500 mm	130 W	-	-	IP54	1	OGIV12280L, AGM Battery 12V 28Ah	
NVGS2101WL	Steelsheet	210 x 400 x 500 mm	210 W	-	-	IP54	1	OGIV12400LP, AGM Battery 12V 40Ah	
NVGS203WL	Steelsheet	210 x 400 x 500 mm	-	20 W	-	IP54	1	OGIV1290LP, AGM Battery 12V 9Ah	
NVGS403WL	Steelsheet	210 x 400 x 500 mm	-	40 W	-	IP54	1	OGIV12170LP, AGM Battery 12V 17Ah	
NVGS653WL	Steelsheet	210 x 400 x 500 mm	-	65 W	-	IP54	1	OGIV12280L, AGM Battery 12V 28Ah	
NVGS903WL	Steelsheet	210 x 400 x 500 mm	-	90 W	-	IP54	1	OGIV12400LP, AGM Battery 12V 40Ah	
NVGS308WL	Steelsheet	210 x 400 x 500 mm	-	-	30 W	IP54	1	OGIV12280L, AGM Battery 12V 28Ah	
NVGS508WL	Steelsheet	210 x 400 x 500 mm	-	-	50 W	IP54	1	OGIV12280L, AGM Battery 12V 45Ah	



GENERAL INFORMATION
DESIGN LUMINAIRES
DYNAMIC LUMINAIRES
UNIVERSAL LUMINAIRES
INDUSTRIAL LUMINAIRES
GENERAL LIGHTING WITH EMERGENCY LIGHT
WIRELESS MONITORING
ACCESSORIES
MODULES

Order number	Housing	Dimensions	Output (inkl. 20% Reserve)			Ingress Protection	Protection class	Battery	
			1h	3h	8h				
SELF-CONTAINED SUPPLY WITH SWITCHABLE WIRELESS PROFESSIONAL MODULE									
NVGS451WLSE	Steelsheet	210 x 400 x 500 mm	45 W	-	-	IP54	1	OGIV1290LP, AGM Battery 12V 9Ah	
NVGS601WLSE	Steelsheet	210 x 400 x 500 mm	60 W	-	-	IP54	1	OGIV12170LP, AGM Battery 12V 17Ah	
NVGS1051WLSE	Steelsheet	210 x 400 x 500 mm	105 W	-	-	IP54	1	OGIV12170LP, AGM Battery 12V 17Ah	
NVGS1301WLSE	Steelsheet	210 x 400 x 500 mm	130 W	-	-	IP54	1	OGIV12280L, AGM Battery 12V 28Ah	
NVGS2101WLSE	Steelsheet	210 x 400 x 500 mm	210 W	-	-	IP54	1	OGIV12400LP, AGM Battery 12V 40Ah	
NVGS203WLSE	Steelsheet	210 x 400 x 500 mm	-	20 W	-	IP54	1	OGIV1290LP, AGM Battery 12V 9Ah	
NVGS403WLSE	Steelsheet	210 x 400 x 500 mm	-	40 W	-	IP54	1	OGIV12170LP, AGM Battery 12V 17Ah	
NVGS653WLSE	Steelsheet	210 x 400 x 500 mm	-	65 W	-	IP54	1	OGIV12280L, AGM Battery 12V 28Ah	
NVGS903WLSE	Steelsheet	210 x 400 x 500 mm	-	90 W	-	IP54	1	OGIV12400LP, AGM Battery 12V 40Ah	
NVGS308WLSE	Steelsheet	210 x 400 x 500 mm	-	-	30 W	IP54	1	OGIV12280L, AGM Battery 12V 28Ah	
NVGS508WLSE	Steelsheet	210 x 400 x 500 mm	-	-	50 W	IP54	1	OGIV12280L, AGM Battery 12V 45Ah	

It is not necessary to state the operation time for Self-Control Versions! Nameplates for all possible operation times will be enclosed.

For Wireless Professional-Versions it is necessary to state the operation time because this is set by default on the radio chip. Not all types are suitable for 8h operation due to the charging unit.

With the NVGS types, a load of less than 18W per output leads to the detection of a lamp fault.

Dimensions small steelsheet housing

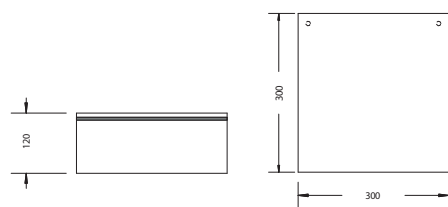

Dimensions large steelsheet housing

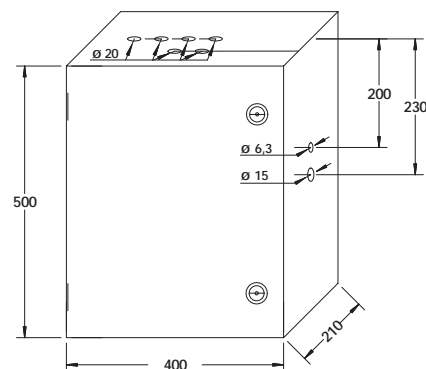

All dimensions in mm

SECURITY IN ACCORDANCE WITH VALID STANDARDS

Our power supply systems are manufactured in cooperation with well-known partner companies according to ISO 9001 and in Germany.

Our plant manufacturing facility as well as selected systems of the multiControl plus series are certified by TÜV Rheinland.

Our power supply systems are developed, manufactured and tested in accordance with the applicable European and national installer standards as well as the applicable directives and electrotechnical requirements.

This applies in particular to:

- DIN EN 50171: 2022-10; Central power supply systems
- DIN EN 50171: 2022-10; Central power supply systems
- DIN EN 50172: 2005; Emergency lighting systems
- DIN VDE 0100-718: 2005; Erection of low-voltage systems - Part 718: Requirements for business premises, rooms and systems of a special kind - Structural systems for gatherings of people
- DIN VDE 0100-560: 08-2022; Erection of low-voltage systems - Part 5-56: Selection and erection of electrical equipment - Equipment for safety purposes (IEC 60364-5-56: 2018, modified)
- DIN VDE 0100-600: 2008; Installation of low voltage systems - Part 6: Tests (IEC 60364-6: 2006, modified)
- DIN VDE V 0108-100-1: 2018-12; Emergency lighting systems
- EN IEC 62485-2:2018; Safety requirements for batteries and battery systems - Part 2: Stationary batteries
- DIN EN 62034: 2013; Automatic test systems for battery-operated emergency lighting for escape routes (IEC 62034: 2012)

OUR SAFETY POWER SUPPLY SYSTEMS

The systems of the multiControl plus series are battery-based safety power supply systems according to EN50171, which are designed for the supply and monitoring of exit sign and emergency luminaires. Up to 96 circuits per system enable the supply and additional line-free monitoring of up to 1920 lights.

The integration of commercially available lights (AC/DC compatible) is possible.

The circuit modules, which operate in AC / DC switchover mode, enable functions such as additional line-less individual light monitoring of up to 20 lights per circuit*, mains monitoring*, maintained, non-maintained or switched maintained luminaire. The mixed operation function* for the operation of maintained and non-maintained lights as well as earth fault, overload and fuse monitoring is integrated in every circuit module.

The display and control unit, consisting of an LC display, keypad and status LEDs, provides information about the current system status and enables configurations directly on the system.

The test book records / stores data over a period of > 5 years. Each system has a BUS interface for connecting external switch request modules (SAM24), network monitors (MC-LM) and signaling and control panels (MCT-15).

A network monitor loop can be monitored on any system of the multiControl plus series, whereby all compact systems have an integrated CCIF for additional detection of clumping. The CCIF is optionally available for the multiControl plus.

Each IOM manages up to 4 freely programmable inputs, e.g. for monitoring functions. The multiControl plus and MDC systems offer the option of connecting up to 5 IO modules in order to implement further messages.

All systems of the multiControl plus series can be visualized and configured via an integrated (patented) web interface.

* not MDC



FROM LOW POWER SYSTEMS TO CENTRAL BATTERY SYSTEMS

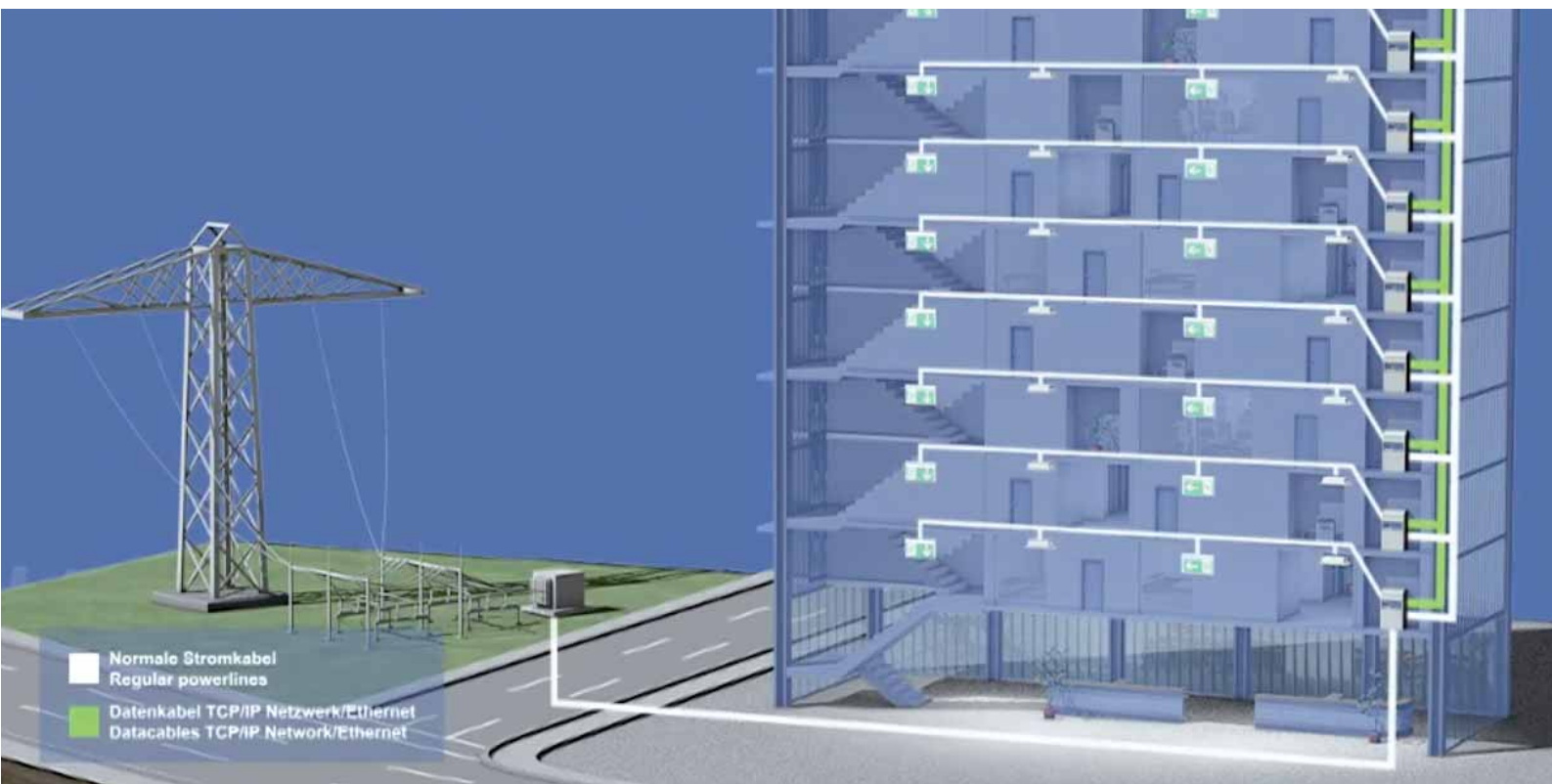

Power supply systems with limited output (Low power systems) form the concept of decentralization of fire compartment-related safety lighting systems to supply emergency and safety lights in the fire compartment. This decentralized concept makes the use of cables in the maintenance of functions, for supplying the lights, superfluous according to MLAR 2005.

Despite decentralized systems, central monitoring and visualization via TCP / IP addressing of the entire system, consisting of up to 33 networked systems, is possible.



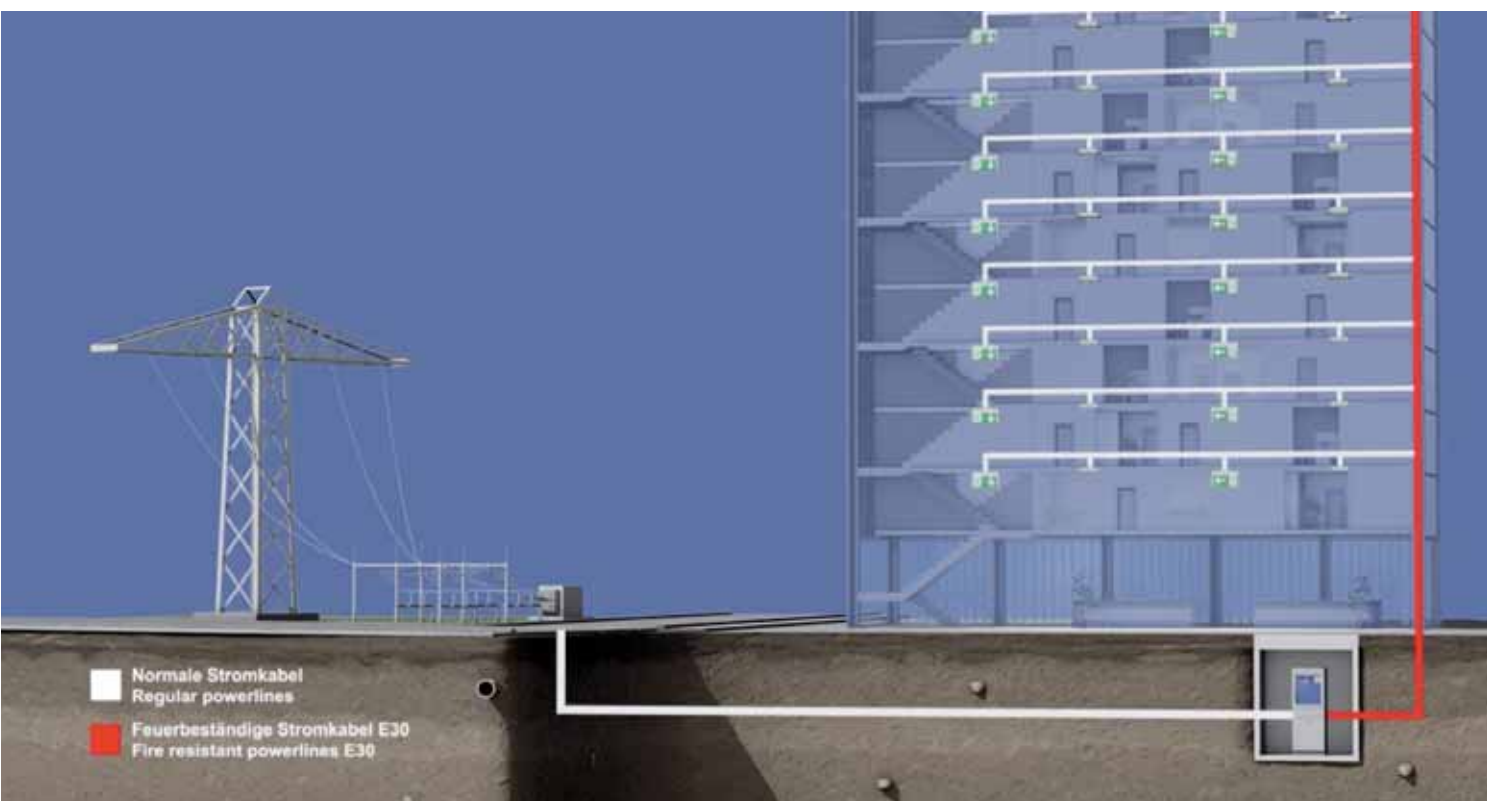

LOW POWER SYSTEMS

CENTRAL BATTERY SYSTEMS

SUBSTATIONS AND
SUBDISTRIBUTIONS

ACCESSORIES AND MODULES

BATTERIA AND
BATTERY MONITORING

Central Battery Systems without power limitation form the concept of cross-fire compartment safety lighting systems for the supply of exit signs and emergency lights from a central point. The individual fire compartments are supplied by fire-proof cables that maintain their function. With up to 96 circuits, a maximum of 1920 lights can be supplied and monitored by the multiControl plus. To meet individual requirements, central battery systems offer the option of connecting substations and sub-distributors. By connecting a maximum of 32 substations, the possible number of luminaires that can be monitored increases to over 63,000. A large selection of different housing variants - from the wall cabinet to the free-standing cabinet - can meet many spatial needs.



CoreCompact 24

4 mains circuits, max. 80 luminaires

The Core Compact 24 emergency lighting system is a state-of-the-art 24-volt low-power system that is extremely easy to install, operate and maintain, offering operational safety and cost-effectiveness at the same time.



microControl *plus*

max. 6 mains circuits, 400 W / 3h, max. 120 luminaires

The microControl *plus* is a decentralized power supply system with limited output (low power system) up to a maximum of 900 W/1h and service-friendly modular plug-in technology.



miniControl *plus*

max. 12 mains circuits, 1500 W / 1h, max. 240 luminaires

The dimensions of the miniControl *plus* lie between the smaller microControl *plus* (500 W / 1h, max. 6 circuits) and the larger miniControl *XI plus* (2500 W / 1h, max. 32 circuits).



miniControl *XL plus*

max. 32 mains circuits, 2510 W / 1h, max. 640 luminaires

The miniControl *XL plus* is the largest low power system with a maximum of 32 circuits and a maximum output of 2510 W / 1h.



midiControl *plus*

max. 32 mains circuits, 5700 W / 1h, max. 640 luminaires

The midiControl *plus* is a preconfigured central battery system with a maximum output of 5700 W / 1h.

As an entry-level model in central battery systems, the midiControl *plus* with its compact motherboard for up to 16 circuit modules and up to 2 charging units offers an optimal price / performance ratio.



multiControl *plus*

max. 96 mains circuits, max. 1920 luminaires

The multiControl *plus* is a central power supply system that convinces with a high degree of flexibility for individual requirements.

A large selection of different housing variants - from the wall cabinet to the free-standing cabinet - can meet many spatial needs. System expansions, which can be found in the options table, can be used to achieve an extensive increase in the range of functions.

» SOPHISTICATED TO THE DETAIL



The connection panel is located on the inside of the cabinet on a mounting plate and is used to connect the system to the power supply, to external signaling and operating elements, and to connect to the consumer circuits. As shown in the figure, the electronics compartment offers enough space for wiring the connecting cables.

Depending on the housing, the cable entries are possible from above or optionally from below. Ventilation openings ensure the necessary air circulation in the electronics and battery compartment.

The central power supply system is available in two separate housings (electronics and battery housings) as a wall or floor cabinet. There is also the option of using a combination housing (see figure), which combines the electronic components and the battery in one housing, but separates them from one another by means of an internal partition.



The painting is carried out as standard using textured paint in the color RAL 7035. In order to achieve optimum service convenience, the electronic components are designed in modular slide-in technology, mounted in the cabinet door, which can optionally be equipped with a transparent door.

As shown, the battery can be placed in the sealed battery compartment of the combination housing or in separate housings or battery racks.



» CENTRAL BATTERY SYSTEMS



MDC

Central battery system

The MDC system is a central battery system with no power limitation. Depending on the housing design of the MDC, there is space for up to 72 circuits of 10 A each, a charging unit of up to 17.5 A and a permanent and standby light switch, in a standing housing.

Single luminaire or circuit monitoring is not possible with this system. The switchability of the circuits is only possible in connection with the associated contactor changeover.



THE SYSTEMS COMPARED

	Core Compact 24	microControl plus	miniControl plus	miniControl XL plus	midiControl plus	multiControl plus	MDC
Cabinet	250 x 455 x 230mm	660 x 350 x 230mm	1100 x 500 x 230mm	1570 x 570 x 230mm	1950 x 600 x 450 mm	several	several
max. mains circuits	4	6 (+1)	12 (+1)	32	32	96	72
max. current per circuits	3,6A	3A	3A	4A	4A	6A	6A
possible mains circuit modules	-	DCM 12-E/32	DCM 12-E/32	DCM 12-E/32/42	DCM 12-E/42	DCM 12-E/32/42/62	-
LPS / CPS	LPS	LPS	LPS	LPS / CPS	CPS	CPS	CPS
Connection of 230 V luminaires							
max.connected load AC (Total)	440 VA	1682 VA	1682 VA	2810 VA	7340VA	47777 VA $\eta=0,9$	47777 VA $\eta=0,9$
max.supply power (Total)	255 W / 1h 85 W / 3h 25 W / 3h	900 W / 1h 400 W / 3h 160 W / 8h	1500 W / 1h 500 W / 3h 330 W / 8h	2510 W / 1h 1230 W / 3h 560W / 8h	5700 W / 1h 2604 W / 3h 1264 W / 8h	43200 W	43200 W
Automatic test facility according to DIN EN 62034							
Single luminaire switching and monitoring without additional wires							
Programmable mains circuits							
Networking of several systems							
Control and monitoring by Web-Interface							
Floor plans in Web-Interface							
Substations / Subdistributions possible							

» THE CPU

The NLSR emergency lighting control computer forms the central display and test facility for the systems. Via the LCD and web interface, it visualizes the system parameters / states and enables the system to be configured.

- Service-friendly modular slide-in technology
- SD card slot
- Ethernet port
- integrated web interface
- 2x USB port 2.0
- multilingual message texts



The software of the NLSR is continuously developed. With the integrated interfaces (SD card slot, USB ports), it is possible to load new firmware without any special programming knowledge.



The Ethernet interface integrated in the control unit enables the system to be completely configured and monitored via a web interface.

The system can be checked by the manufacturer in the event of service. For this it is necessary to integrate the system into an existing network with an internet connection.



The integrated USB ports offer the option of a standard USB keyboard for configuration of the system via LCD, connection of an external printer (PCL6) and firmware update using a USB stick.

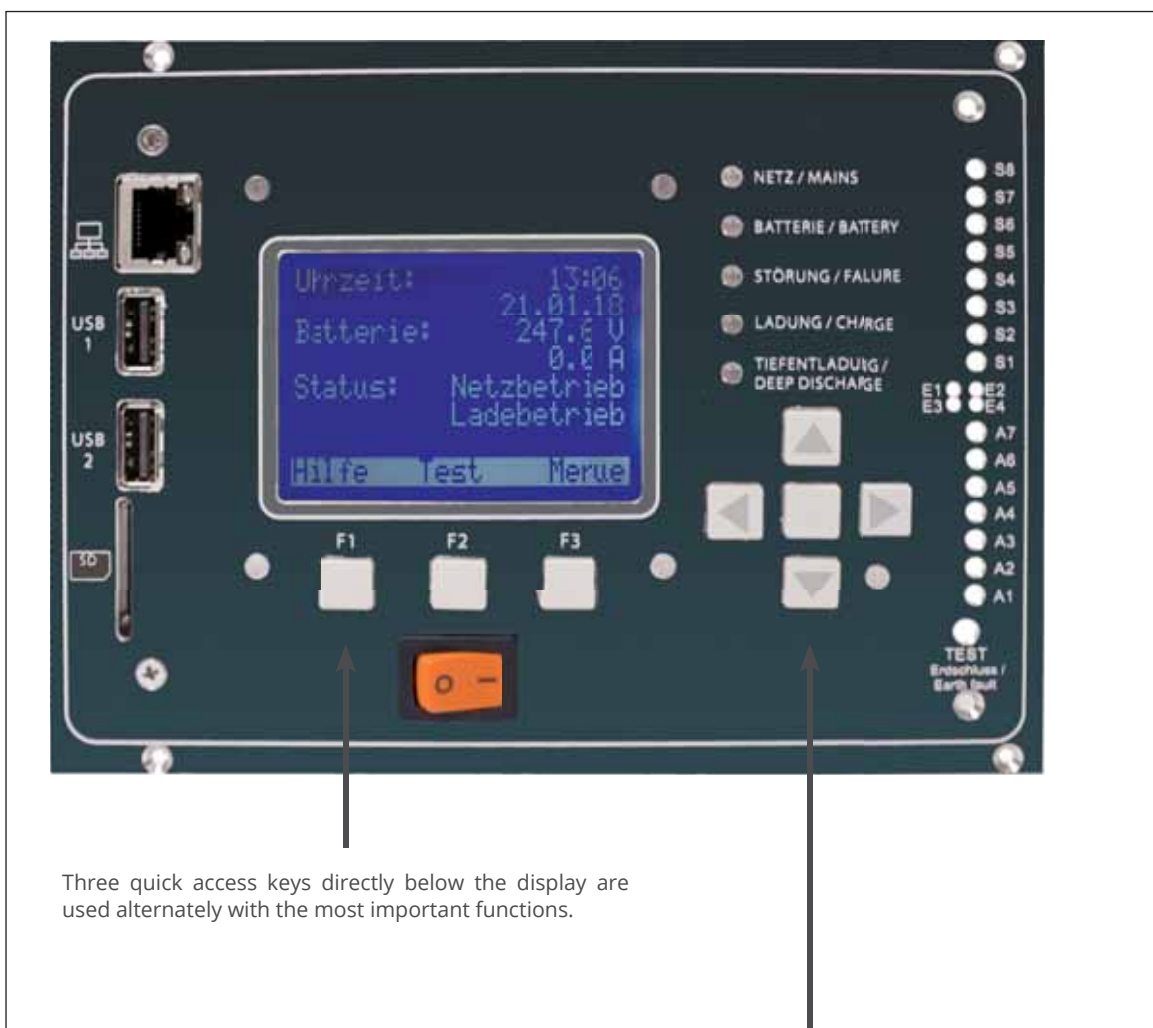

Three quick access keys directly below the display are used alternately with the most important functions.

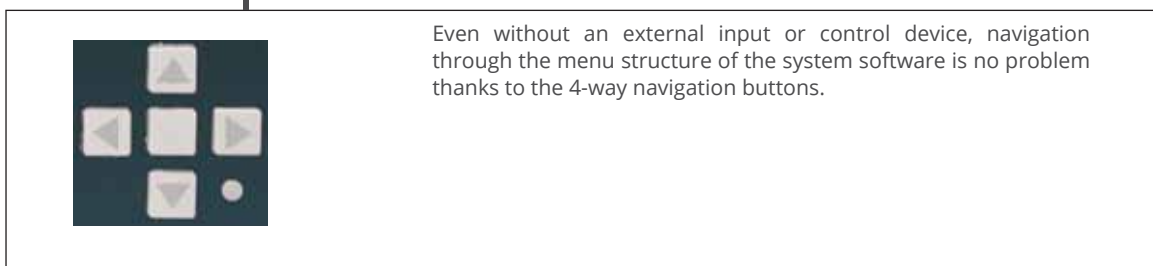

Even without an external input or control device, navigation through the menu structure of the system software is no problem thanks to the 4-way navigation buttons.



Each safety power supply system is also available with a touchdisplay.

» THE WEB-INTERFACE



The innovative Web-Interface of the multiControl plus series enables information on the system status to be queried with the well-known Internet browsers.

The selectable system status shows information on the current system status, contact details, the result of the last function test and an overview of the circuits.



Individually stored building floor plans make it easier to find faulty lights.

Each installed luminaire can be placed using „drag & drop“ and displayed graphically with type and operating mode.

The plans for the building can be saved as a file directly in the NLSR or, in the case of larger data volumes, on a connected NAS drive.

» SINGLE LUMINAIRE SWITCHING

When using the DCM12E circuit module, it is possible to switch our luminaires individually and without additional cables in the circuit.

The DCM12E circuit module is designed for use in systems of the multiControl *plus* series (except myControl plus).

The circuit parameters (number of luminaires, operating mode and switching commands) are configured via the Web-Interface.

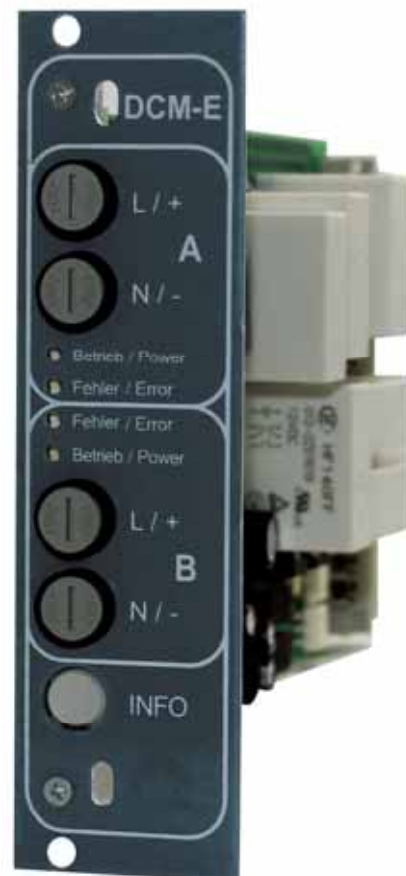

24V LOW POWER SYSTEM

CORE COMPACT 24 – LOW POWER SYSTEM

The Core Compact 24 emergency lighting system is a state-of-the-art 24-volt low-power system that is extremely easy to install, operate and maintain, offering operational safety and cost-effectiveness at the same time.

The system can be installed and maintained from any end device via an intuitive web interface that, thanks to its modern, responsive design, automatically adapts to the respective screen size. The graphical user interface guarantees increased ease of use and thus short training times for the installer and the Employees of the building operator. A central software update for all system components, including the connected lights, can be carried out from the control center in just a few simple steps via the integrated USB interface. This reduces the effort for data backups and firmware updates to a minimum.

All lights are centrally programmable and dimmable. Schedules can also be programmed, for example to control function tests, scenes and to define building quiet times. These features ensure flexible adaptation to demanding application requirements.

An intelligent setup wizard makes the most important settings at the push of a button, automatically assigns all lights to the correct operating mode as permanent light or stand-by light, and thus shortens the commissioning time, which saves costs and effort.

Thanks to our tried-and-tested monitoring technology, which detects line breaks and short-circuits alike, expensive E30 material can be dispensed with when designing the network monitor loop. Messages on the system status of the system are displayed both on the integrated touch display and on the web interface that can be operated externally. Automatic e-mail notifications when errors occur increase operational reliability. In addition, the system can easily communicate its status to an existing building management system using freely programmable relay contacts.

The system automatically keeps a log book that helps the in-house technician save time during service and maintenance. This means that hardly any additional documentation is required for regular checks. The protective extra-low voltage of maximum 24 volts on the output side guarantees safe working on the system and the connected lights at all times.

When delivered, the system is equipped with a lithium iron phosphate battery. Compared to conventional lead-acid batteries, this type of battery offers a high level of intrinsic safety and a significantly longer service life.





FACTS

Version:	Wall mounting								
Housing:	Steel sheet RAL7016/9010								
Dimensions:	250 x 455 x 230mm								
Protection category:	IP20								
Insulation class:	I (Input) / III (Output)								
Mains connection:	230V AC								
Battery:	LiFePO ₄ , 20 Ah or 2x 20 Ah								
permissible ambient Temperature:	10° to 35°C								
max. connecting load (AC):	440A								
max. supply power (AC):	<table border="0"> <tr> <td>20 Ah</td> <td>2x 20 Ah</td> </tr> <tr> <td>255 W / 1h</td> <td>255 W / 1h</td> </tr> <tr> <td>85 W / 3h</td> <td>190 W / 3h</td> </tr> <tr> <td>25 W / 8h</td> <td>60 W / 8h</td> </tr> </table>	20 Ah	2x 20 Ah	255 W / 1h	255 W / 1h	85 W / 3h	190 W / 3h	25 W / 8h	60 W / 8h
20 Ah	2x 20 Ah								
255 W / 1h	255 W / 1h								
85 W / 3h	190 W / 3h								
25 W / 8h	60 W / 8h								

FEATURES AT A GLANCE:

- Smart 24-volt emergency lighting system with automatic monitoring of the system and lights without a separate data line.
- Easy installation and commissioning thanks to the configuration assistant with intelligent self-configuration of the lights.
- Convenient operation and monitoring via touch display and modern web interface from any device.
- Lights can be programmed and dimmed individually for flexible adaptation to modern energy concepts.
- Function tests manually or via schedules. Automatic logbook and battery discharge diagram for each test to save time during service and maintenance.
- High future security thanks to the option to update all system components via the integrated USB interface.
- Safe emergency power supply thanks to long-lasting and gas-free lithium iron phosphate battery.
- Compact, lightweight and easy to maintain.

Version	Order number	Battery power	Mains circuits	max. luminaires
Core Compact 24 Compact system	CC24-20	20 Ah	4	80
Core Compact 24 Compact system	CC24-40	2x 20 Ah	4	80

ACCESSORIES

PC230	Mains Monitoring module
C-MA-AP01	Core alarm display with optical and acoustic status indicator, surface-mounted
C-MA-UP01	Core alarm display with optical and acoustic status indicator, recessed mounted



» microControl plus

LOW POWER SYSTEM



Image showing optional Touch Display

MICROCONTROL *PLUS* – DECENTRALIZED POWER SUPPLY SYSTEM WITH LIMITED OUTPUT

The microControl plus is a decentralized power supply system with limited output (low power system) up to a maximum of 900 W and service-friendly modular plug-in technology.

This system can be equipped with up to 6 circuits, each of which switches independently and is fused bipolar.

Various switching states can be implemented with the circuits via switch query modules or network monitors. A SAM with 8 inputs is integrated, 15 additional BUS modules can be connected to the system via the BUS interface.

An IO module for forwarding the system status to an external display unit or a building management system via potential-free contacts is integrated in the microControl plus. The microControl plus also has four freely programmable voltage inputs. The connection to the building management system via Modbus or BACnet is possible via another interface.

A CCIF is integrated to monitor a potential-free network monitor loop for interruption and / or termination.

A supply and monitoring of a 24V DC fan is available for the ventilation of optional E30 fire protection distributor housings.

Switched mode enables the connection of our luminaires listed in the catalog, as well as commercially available luminaires, which are designed for supply by an AC and DC voltage.



FACTS

Version:	Wall housing
Cabinet:	Steel sheet RAL 7035
Dimensions (HxWxD):	660 x 350 x 230mm
Dimensions „E30“ (HxWxD):	918 x 711 x 365mm
Protection category:	IP20 („E30“: IP50)
Insulation class:	I
Mains connection:	230 V AC (±10%) 50/60Hz
Switched mode:	230 V AC / 216 V DC ±15%
Battery:	216 V DC 18x 12 V / 5.2, 7 or 9 Ah
Permissible temp.:	10° to 35° C
max. connected load AC:	1682 VA
max. connected load DC:	up to 900 W / 1h 400 W / 3h 160 W / 8h

FEATURES AT A GLANCE:

- Power supply system according to DIN EN 50171 for safety lighting systems according to DIN EN 50172 and systems according to DIN VDE 0100-718
- automatic test facility according to DIN EN 62034
- Combined switching type for maintained, non-maintained and switched maintained light
- Service-friendly modular 19 "slide-in technology
- Electronic test book for recording all data over a period of > 5 years
- multilingual menu navigation, e.g. German English
- Management and error display of up to 20 lights each circuit
- 6 circuits of max. 650 VA
- 1 auxiliary circuit max. 150 VA
- Maximum connected load (AC operation) of 1682 VA
- Status information of the system in plain text as well as status LEDs
- Interface for external modules SAM24, MC-LM, MCT15 via RS485BUS
- up to 6 switching inputs per circuit
- Networking of systems possible via Ethernet (TCP / IP)
- Web interface for visualization and configuration

integrated light switch query module SAM:

- 8x switching input on terminal (200 - 255 V AC or 24 - 255 V DC) for switching the circuits in AC operation
- 3 circuit types (sw. maintained, maintained, non-maintained) programmable

integrated IO module:

- 7x relay output, 230 V AC, 6 A / 30 V DC, 6A, floating changeover contact
- 4x galvanically isolated switching input (200 - 255 V AC or 24 - 255 V DC), reverse polarity-tolerant, function programmable

integrated CCIF - Critical Circuit Interface Module

- Monitoring of a potential-free network monitor loop for interruption and termination of the line



Version	Order number	Mains circuits	max. Luminaires
microControl <i>plus</i> 102	MI102	2	40
microControl <i>plus</i> 104	MI104	4	80
microControl <i>plus</i> 106	MI106	6	120

Batteries 5,2 Ah, 7 Ah or 9 Ah have to be ordered separately.

» miniControl plus

LOW POWER SYSTEM

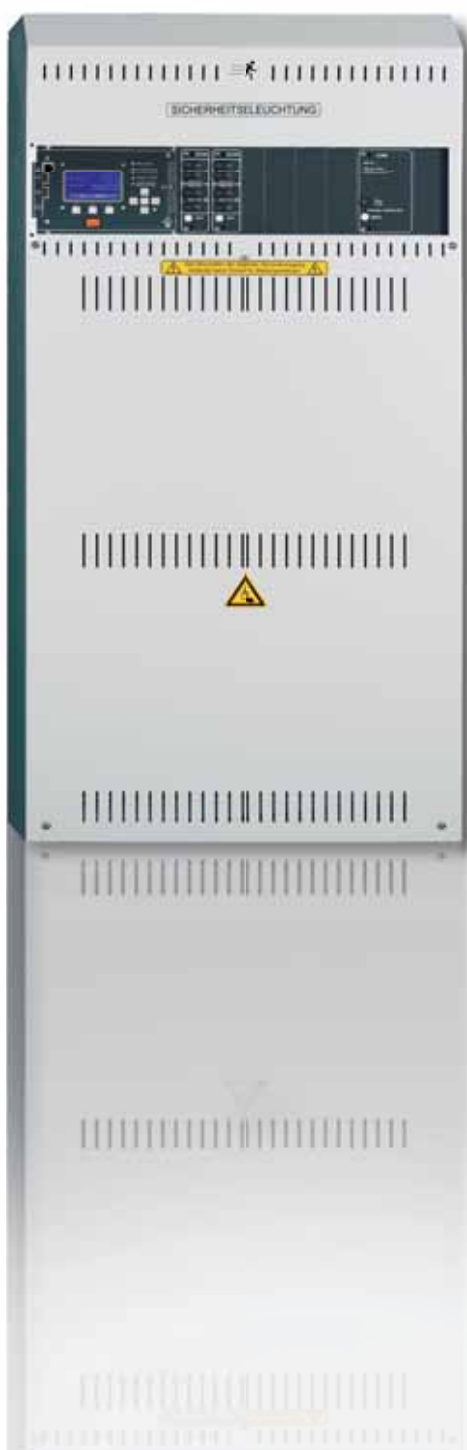

MINICONTROL PLUS – DECENTRALIZED POWER SUPPLY SYSTEM WITH LIMITED OUTPUT

The miniControl plus is a decentralized power supply system with limited output (low power system) up to a maximum of 1500 W and service-friendly modular plug-in technology.

This system can be equipped with up to 12 circuits, each switching independently and being fused bipolar.

Various switching states can be implemented with the circuits via switch query modules or network monitors. A SAM with 8 inputs is integrated, 15 additional BUS modules can be connected to the system via the BUS interface.

An IO module for forwarding the system status to an external display unit or a building management system via potential-free contacts is integrated in the miniControl plus. The miniControl plus also has four freely programmable voltage inputs. The connection to the building management system via Modbus or BACnet is possible via another interface.

A CCIF is integrated to monitor a potential-free network monitor loop for interruption and / or termination.

A supply and monitoring of a 24V DC fan is available for the ventilation of optional E30 fire protection distributor housings.

Switched mode enables the connection of our luminaires listed in the catalog, as well as commercially available luminaires, which are designed for supply by an AC and DC voltage.



FACTS

Version:	Wall housing
Cabinet:	Steel sheet RAL 7035
Dimensions (HxWxD):	1100 x 500 x 230mm
Dimensions „E30“ (HxWxD):	1388 x 861 x 365mm
Protection category:	IP20 („E30“: IP50)
Insulation class:	I
Mains connection:	230 V AC (±10%) 50/60Hz
Switched mode:	230 V AC / 216 V DC ±15%
Battery:	216 V DC
	18x 12 V / 17 Ah
Permissible temp.:	10° to 35° C
max. connected load AC:	1682 VA
max. connected load DC:	1500 W / 1h
	500 W / 3h
	330 W / 8h

FEATURES AT A GLANCE:

- Power supply system according to DIN EN 50171 for safety lighting systems according to DIN EN 50172 and systems according to DIN VDE 0100-718
- automatic test facility according to DIN EN 62034
- Combined switching type for maintained, non-maintained and switched maintained light
- Service-friendly modular 19 "slide-in technology
- Electronic test book for recording all data over a period of > 5 years
- multilingual menu navigation, e.g. German English
- Management and error display of up to 20 lights each circuit
- 12 circuits of max. 650 VA
- 1 auxiliary circuit max. 150 VA
- Maximum connected load (AC operation) of 1682 VA
- Status information of the system in plain text as well as status LEDs
- Interface for external modules SAM24, MC-LM, MCT15 via RS485BUS
- up to 6 switching inputs per circuit
- Networking of systems possible via Ethernet (TCP / IP)
- Web interface for visualization and configuration

integrated light switch query module SAM:

- 8x switching input on terminal (200 - 255 V AC or 24 - 255 V DC) for switching the circuits in AC operation
- 3 circuit types (sw. maintained, maintained, non-maintained) programmable

integrated IO module:

- 7x relay output, 230 V AC, 6 A / 30 V DC, 6A, floating changeover contact
- 4x galvanically isolated switching input (200 - 255 V AC or 24 - 255 V DC), reverse polarity-tolerant, function programmable

integrated CCIF - Critical Circuit Interface Module

- Monitoring of a potential-free network monitor loop for interruption and termination of the line



Version	Order number	Mains circuits	max. Luminaires
miniControl plus 102	MN102	2	40
miniControl plus 104	MN104	4	80
miniControl plus 106	MN106	6	120
miniControl plus 108	MN108	8	160
miniControl plus 110	MN110	10	200
miniControl plus 112	MN112	12	240

» miniControl XL plus

CENTRAL POWER SYSTEM



Image showing optional Touch Display

MINICONTROL XL PLUS – POWER SUPPLY SYSTEM WITH LIMITED OUTPUT

The miniControl XL plus is a decentralized power supply system with limited output (low power system) up to a maximum of 2510 W and service-friendly modular plug-in technology.

This system can be equipped with up to 32 circuits, each of which switches independently and is fused bipolar.

Various switching states can be implemented with the circuits via switch query modules or network monitors. A SAM with 8 inputs is integrated, 15 additional BUS modules can be connected to the system via the BUS interface.

An IO module for forwarding the system status to an external display unit or a building management system via potential-free contacts is integrated in the miniControl XL plus. The miniControl XL plus also has four freely programmable voltage inputs. The connection to the building management system via Modbus or BACnet is possible via another interface.

A CCIF is integrated to monitor a potential-free network monitor loop for interruption and / or termination.

A supply and monitoring of a 24V DC fan is available for the ventilation of optional E30 fire protection distributor housings.

Switched mode enables the connection of our luminaires listed in the catalog, as well as commercially available luminaires, which are designed for supply by an AC and DC voltage.

**Also available with BAT-LOGG®:
Making batteries smart!**



FACTS

Version:	Wall housing
Cabinet:	Steelsheet RAL 7035
Dimensions (HxWxD):	1472,5 x 570 x 230mm
Dimensions „E30“ (HxWxD):	1828 x 908 x 395mm
Protection category:	IP20 („E30“: IP50)
Insulation class:	I
Mains connection:	230 V AC (±10%) 50/60Hz
Switched mode:	230 V AC / 216 V DC ±15%
Battery:	216 V DC 18x 12 V 5,2 / 7 / 9 / 12 / 17 or 28 Ah
Permissible temp.:	10° to 35° C
max. connected load AC:	2810 VA
max. connected load DC:	2510 W / 1 h 1230 W / 3 h 560 W / 8 h

With batteries up to 17Ah Ah, the miniControl XL meets the guidelines for a low power system.

FEATURES AT A GLANCE:

- Power supply system according to DIN EN 50171 for safety lighting systems according to DIN EN 50172 and systems according to DIN VDE 0100-718
- automatic test facility according to DIN EN 62034
- Combined switching type for standby, steady light and switched steady light
- Service-friendly modular 19 "slide-in technology
- Electronic test book for recording all data over a period of > 5 years
- multilingual menu navigation, e.g. German English
- Management and error display of up to 20 lights each circuit
- 32 circuits
- Maximum connected load (AC operation) of 2810 VA
- Status information of the system in plain text as well as status LEDs
- Interface for external modules SAM24, MC-LM, MCT15 via RS485BUS
- up to 6 switching inputs per circuit
- Networking of systems possible via Ethernet (TCP / IP)
- Web interface for visualization and configuration

integrated light switch query module SAM:

- 8x switching input on terminal (200 - 255 V AC or 24 - 255 V DC) for switching the circuits in AC operation
- 3 circuit types (sw. maintained, maintained, non-maintained) programmable

integrated IO module:

- 7x relay output, 230 V AC, 6 A / 30 V DC, 6A, floating changeover contact
- 4x galvanically isolated switching input (200 - 255 V AC or 24 - 255 V DC), reverse polarity-tolerant, function programmable

integrated CCIF - Critical Circuit Interface Module

- Monitoring of a potential-free network monitor loop for interruption and termination of the line

Version	Order number	Mains circuits	max. Luminaires
miniControl XL <i>plus</i> 102	MNXL102	2	40
miniControl XL <i>plus</i> 104	MNXL104	4	80
miniControl XL <i>plus</i> 106	MNXL106	6	120
miniControl XL <i>plus</i> 108	MNXL108	8	160
...
miniControl XL <i>plus</i> 132	MNXL132	32	640

Batteries have to be ordered separately.

CENTRAL BATTERY SYSTEM



MIDICONTROL PLUS – CENTRAL BATTERY SYSTEM

The midiControl plus is a central battery system up to a maximum of 5700 W and service-friendly modular slide-in technology.

This system can be equipped with up to 32 circuits, each of which switches independently and is fused bipolar.

Various switching states can be implemented with the circuits via switch query modules or network monitors. A SAM with 8 inputs is integrated, 15 additional BUS modules can be connected to the system via the BUS interface.

An IO module for forwarding the system status to an external display unit or a building management system via floating contacts is integrated in the midiControl plus. The midiControl plus also has four freely programmable voltage inputs. The connection to the building management system via Modbus or BACnet is possible via another interface.

A CCIF is integrated to monitor a potential-free network monitor loop for interruption and / or termination.

Switched mode enables the connection of our luminaires listed in the catalog, as well as commercially available luminaires, which are designed for supply by an AC and DC voltage.

With up to two 2.5A chargers and battery housings up to a maximum battery size of 55 Ah, an output of 5700W is possible for one hour.

**Also available with BAT-LOGG®:
Making batteries smart!**



FACTS

Version:	Tower housing
Cabinet:	Steel sheet RAL 7035
Dimensions (HxWxD):	1950 x 600 x 450mm
Protection category:	IP20
Insulation class:	I
Mains connection:	3x 230 V AC (±10%) 50/60Hz
Switched mode:	230 V AC / 216 V DC ±15%
Battery:	216 V DC max. 18x 12 V / 55 Ah
Permissible temp.:	10° to 35° C
max. connected load AC:	7340 VA
max. connected load DC*:	5700 W / 1h 2604 W / 3h 1264 W / 8h

* Battery-dependent, the values given correspond to 55 Ah

FEATURES AT A GLANCE:

- Central power supply system according to DIN EN 50171 for safety lighting systems according to DIN EN 50172 and systems according to DIN VDE 0100-718
- automatic test facility according to DIN EN 62034
- Combined switching type for maintained, non-maintained and switched maintained light
- Service-friendly modular 19 "slide-in technology
- Electronic test book for recording all data over a period of > 5 years
- multilingual menu navigation, e.g. German English
- Management and error display of up to 20 lights each circuit
- 32 circuits of max. 860 VA
- Maximum connected load (AC operation) of 7340 VA
- Status information of the system in plain text as well as status LEDs
- Interface for external modules SAM24, MC-LM, MCT15 via RS485BUS
- up to 6 switching inputs per circuit
- Networking of systems possible via Ethernet (TCP / IP)
- Web interface for visualization and configuration

Integrated light switch query module SAM:

- 8x switching input on terminal (200 - 255 V AC or 24 - 255 V DC) for switching the circuits in AC operation
- 3 circuit types (sw. maintained, maintained, non-maintained) programmable

Integrated IO module:

- 7x relay output, 230 V AC, 6 A / 30 V DC, 6A, floating changeover contact
- 4x galvanically isolated switching input (200 - 255 V AC or 24 - 255 V DC), reverse polarity-tolerant, function programmable

Integrated CCIF - Critical Circuit Interface Module

- Monitoring of a potential-free network monitor loop for interruption and termination of the line

Version	Order number	Charger	Mains circuits	max. Luminaires
midicontrol <i>plus</i> 102	MD102	1	2	40
midicontrol <i>plus</i> 104	MD104	1	4	80
...
midicontrol <i>plus</i> 132	MD132	1	32	640
midicontrol <i>plus</i> 202	MD202	2	2	40
midicontrol <i>plus</i> 204	MD204	2	4	80
...
midicontrol <i>plus</i> 232	MD232	2	32	640

CENTRAL BATTERY SYSTEM



MULTICONTROL PLUS – CENTRAL BATTERY SYSTEM

The multiControl plus is a central battery system up to a maximum of 43200 W and service-friendly modular slide-in technology.

This system can be equipped with up to 96 circuits, each of which switches independently and is fused bipolar.

Various switching states can be implemented with the circuits via switch query modules or network monitors. Up to 16 BUS modules can be connected to the system via the BUS interface.

An IO module for forwarding the system status to an external display unit or a building management system via potential-free contacts is integrated in the multiControl plus. The multiControl plus also has two programmable voltage inputs connected to the terminal. The connection to the building management system via Modbus or BACnet is possible via another interface.

The monitoring of a potential-free network monitor loop for interruption is integrated. The monitoring of the network monitor loop for clumping / closing is optionally possible.

Switched mode enables the connection of our luminaires listed in the catalog, as well as commercially available luminaires, which are designed for supply by an AC and DC voltage.

With up to ten 2.5A chargers as standard and battery sets connected in parallel, a maximum output of 43200W is possible for one hour.

Up to 32 systems or substations can be connected to the multiControl plus and monitored.

By using sub-distributors of type MCVU and MCVU-E, circuits of the multiControl plus can be outsourced based on the fire compartment, thereby reducing the fire load and the installation material.

**Also available with BAT-LOGG®:
Making batteries smart!**



FACTS

Version:	Tower- / Surface or wall housing
Cabinet:	Steelsheet RAL 7035
Dimensions:	see systems list
Protection category:	IP20 (optional IP21, IP54, E30)
Insulation class:	I
Mains connection:	3 x 230V AC (± 10%) 50/60Hz
Switched mode:	230 V AC / 216 V DC ±15%
Battery:	216 V DC, Up to three strings of 18 x 12V lead acid batteries
permissible Temp.:	10°C to 35°C
Cable feed:	from Top (from below on request)



FEATURES AT A GLANCE:

- Central power supply system according to DIN EN 50171 for safety lighting systems according to DIN EN 50172 and systems according to DIN VDE 0100-718
- automatic test facility according to DIN EN 62034
- Combined switching type for maintained, non-maintained and switched maintained light
- Service-friendly modular 19 "slide-in technology
- Electronic test book for recording all data over a period of > 5 years
- multilingual menu navigation, e.g. German English
- Management and error display of up to 20 lights each circuit
- 96 circuits of max. 1300 VA
- Maximum connected load (AC operation) of 47777 VA
- Status information of the system in plain text as well as status LEDs
- Interface for external modules SAM24, MC-LM, MCT15 via RS485BUS
- up to 6 switching inputs per circuit
- Networking of systems possible via Ethernet (TCP / IP)
- Web interface for visualization and configuration

Optional light switch query module SAM:

- 8x switching input on terminal (200 - 255 V AC or 24 - 255 V DC) for switching the circuits in AC operation
- 3 circuit types (sw. maintained, maintained, non-maintained) programmable

Integrated IO module:





- 7x relay output, 230 V AC, 6 A / 30 V DC, 6A, floating changeover contact
- 4x galvanically isolated switching input (200 - 255 V AC or 24 - 255 V DC), reverse polarity-tolerant, function programmable

Integrated monitoring of a mains monitor loop

- Monitoring of a potential-free mains monitor loop for interruption and termination of the line

CENTRAL BATTERY SYSTEM

Auszug aus der Anlagenliste – weitere Konfigurationen sind möglich

Version	Order number	Charger	Cabinet HxWxD	max. circuits	max. DCM	
Combi device incl. central unit and battery compartment up to 17Ah, AC-Feeding 1x, 2x or 3x 230V, 50/60Hz						
	multiControl plus 12/2,5A Combi 1000	MCK112	2,5A	1000 x 600 x 400	12	6
	multiControl plus 24/2,5A Combi 1000	MCK124	2,5A	1000 x 600 x 400	24	12
	multiControl plus 36/2,5A Combi 1000	MCK136	2,5A	1000 x 600 x 400	36	18
Combi device incl. central unit and battery compartment up to 45Ah, AC-Feeding 1x, 2x or 3x 230V, 50/60Hz						
	multiControl plus 12/2,5A Combi 1500	MCG112	2,5A	1500 x 600 x 450	12	6
	multiControl plus 24/2,5A Combi 1500	MCG124	2,5A	1500 x 600 x 450	24	12
	multiControl plus 36/2,5A Combi 1500	MCG136	2,5A	1500 x 600 x 450	36	18
Surface- / Wall housing, without battery compartment, incl. charger AC-Feeding 1x, 2x or 3x 230V, 50/60Hz						
	multiControl plus 900 12/2,5A	MCW112	2,5A	900 x 600 x 450	12	6
	multiControl plus 900 24/2,5A	MCW124	2,5A	900 x 600 x 450	24	12
	multiControl plus 900 36/5,0A	MCW236	5,0A	900 x 600 x 450	36	18
	multiControl plus 900 36/7,5A	MCW336	7,5A	900 x 600 x 450	36	18
	multiControl plus 900 48/7,5A	MCW348	7,5A	900 x 600 x 450	48	24
Tower Housing incl. central unit, without battery compartment, incl. charger, AC-Feeding 1x, 2x or 3x 230V, 50/60Hz						
	multiControl plus 1800 12/7,5A	MCS312	7,5A	1800 x 600 x 450	12	6
	multiControl plus 1800 12/10,0A	MCS412	10,0A	1800 x 600 x 450	12	6
	multiControl plus 1800 12/12,5A	MCS512	12,5A	1800 x 600 x 450	12	6
	multiControl plus 1800 12/15,0A	MCS612	15,0A	1800 x 600 x 450	12	6
	multiControl plus 1800 12/17,5A	MCS712	17,5A	1800 x 600 x 450	12	6
	multiControl plus 1800 12/20,0A	MCS812	20,0A	1800 x 600 x 450	12	6
	multiControl plus 1800 12/22,5A	MCS912	22,5A	1800 x 600 x 450	12	6
	multiControl plus 1800 12/25,0A	MCS1012	25,0A	1800 x 600 x 450	12	6
	multiControl plus 1800 24/20,0A	MCS824	20,0A	1800 x 600 x 450	24	12
	multiControl plus 1800 24/25,0A	MCS1024	25,0A	1800 x 600 x 450	24	12
	multiControl plus 1800 36/10,0A	MCS436	10,0A	1800 x 600 x 450	36	18
	multiControl plus 1800 36/20,0A	MCS836	20,0A	1800 x 600 x 450	36	18
	multiControl plus 1800 36/25,0A	MCS1036	25,0A	1800 x 600 x 450	36	18
	multiControl plus 1800 48/12,5A	MCS548	12,5A	1800 x 600 x 450	48	24
	multiControl plus 1800 48/25,0A	MCS1048	25,0A	1800 x 600 x 450	48	24
	multiControl plus 1800 60/20,0A	MCS860	20,0A	1800 x 600 x 450	60	30
	multiControl plus 1800 72/15,0A	MCS672	15,0A	1800 x 600 x 450	72	36
	multiControl plus 1800 72/25,0A	MCS1072	25,0A	1800 x 600 x 450	72	36
	multiControl plus 1800 96/15,0A	MCS696	15,0A	1800 x 600 x 450	96	48

Further system configurations on request (e.g. additional loaders, MCABUS, etc.)

* Attention: When connecting substations / sub-distributors or installing optional modules (SAM24M), please contact our technical department in advance (additional space may be required in the cabinet)!

This can reduce the max. number of possible circuits or the number of charger modules!

GEHÄUSE



Type	MCW	MCK	MCG	MCS	MCX
Cabinet	Wall housing	Tower-/ Wall housing	Tower housing	Tower housing	Tower housing
Dimensions in mm	900 x 600 x 450	1000 x 600 x 400	1500 x 600 x 450	1800 x 600 x 450	1850 x 800 x 600
Cable feed	from Top (from below on request)				
max. charging current	7,5 A	2,5 A	2,5 A	25 A	10 A
max. mains circuits	48	36	48	96	60
Mains connection	400 V AC, 50/60 Hz				

CONNECTION DIAGRAM MULTICONTROL

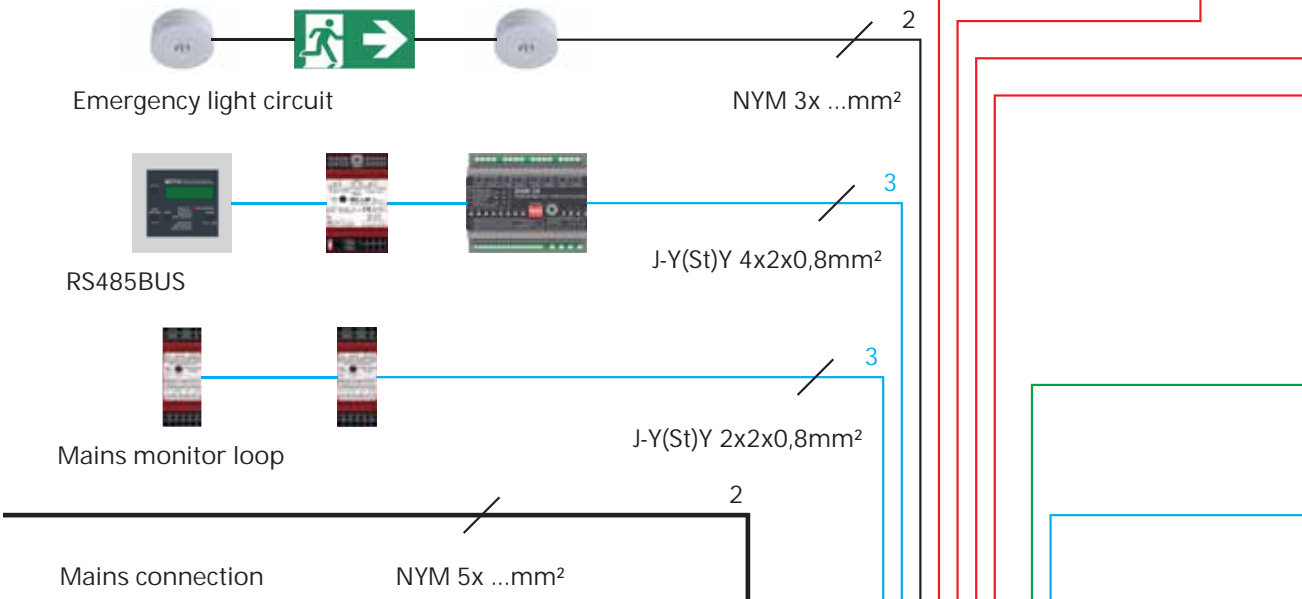
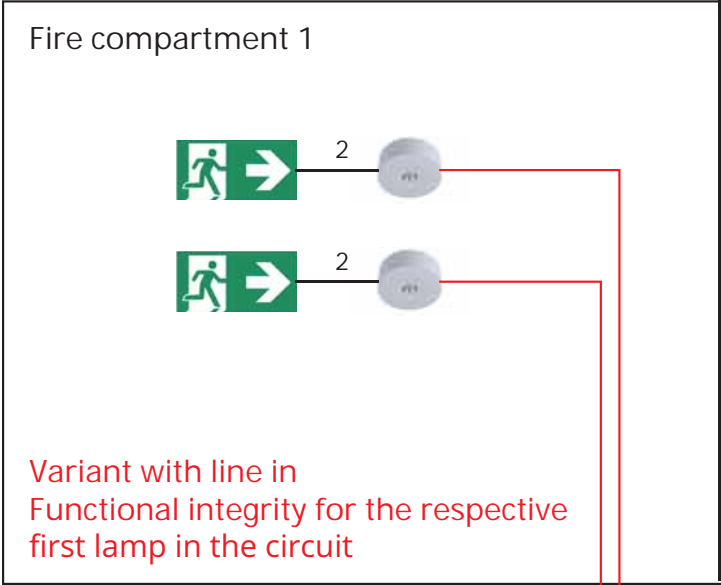

- 1 — Line in functional integrity (N)HXH ... 3x ...
- 2 — Normal mains line NYM...
- 3 — Data cable J-Y(St)Y
- 4 — Network cable Cat.5 / Cat.7



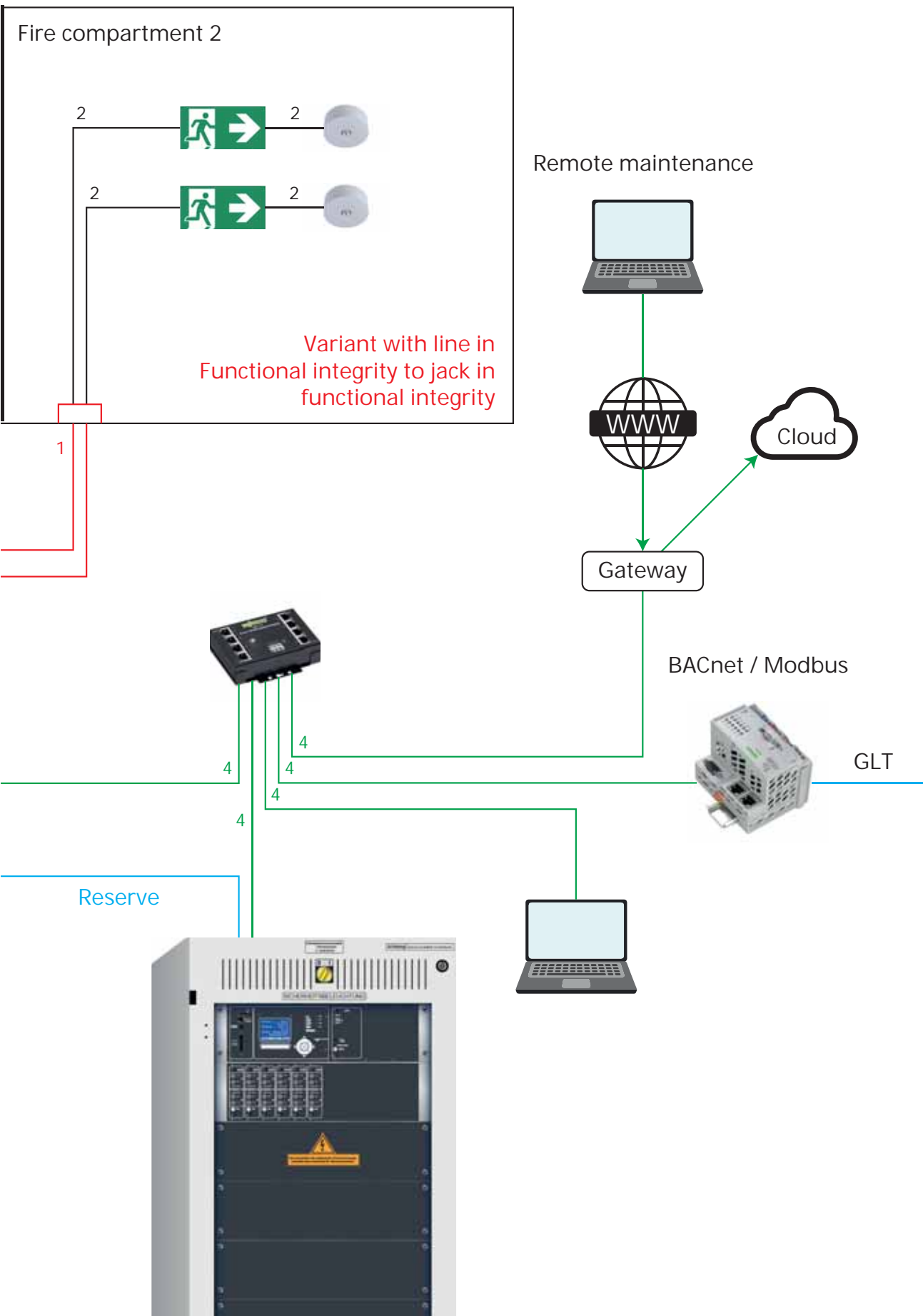

CENTRAL BATTERY SYSTEM



MDC – CENTRAL BATTERY SYSTEM

The MDC is a central battery system up to a maximum of 43200 W and service-friendly modular slide-in technology.

This system is equipped with separate two-pole fused circuits. The system is switched via AC / DC contactor switches. The combined operation of continuous and standby lights (mixed operation), individual light monitoring and current monitoring of individual circuits is not possible.

Various switching states can be implemented with the contactor changeovers via switch query modules or network monitors. Up to 16 BUS modules can be connected to the system via the BUS interface.

An IO module for forwarding the system status to an external display unit or a building management system via potential-free contacts is integrated in the MDC. The MDC also has two programmable voltage inputs connected to the terminal. The connection to the building management system via Modbus or BACnet is possible via another interface.

The monitoring of a potential-free network monitor loop for interruption is integrated. The monitoring of the network monitor loop for clumping / closing is optionally possible, depending on the requirements for the overall system or selectively for each contactor changeover.

Switched mode enables the connection of our luminaires listed in the catalog, as well as commercially available luminaires, which are designed for supply by an AC and DC voltage.

With up to ten 2.5A chargers as standard and battery sets connected in parallel, a maximum output of 43200W is possible for one hour.

Up to 32 systems or substations can be connected to the MDC and monitored.

**Also available with BAT-LOGG®:
Making batteries smart!**

FACTS

Version:	Tower- / Wall housing
Cabinet:	Steelsheet RAL 7035
Dimensions:	see systems list
Protection category:	IP20 (optional IP21, IP54, E30)
Insulation class:	I
Mains connection:	3 x 230V AC ($\pm 10\%$) 50/60Hz
Switched mode:	230 V AC / 216 V DC $\pm 15\%$
Battery:	216 V DC, 18x 12 V maintenance free closed lead acid battery
permissible Temp.:	10°C to 35°C
Cable feed:	from Top (from below on request)

FEATURES AT A GLANCE:

- Central power supply system according to DIN EN 50171 for safety lighting systems according to DIN EN 50172 and systems according to DIN VDE 0100-718
- Service-friendly modular 19 "slide-in technology
- Electronic test book for recording all data over a period of > 5 years
- multilingual menu navigation, e.g. German English
- Maximum connected load (AC operation) of 47777 VA
- Status information of the system in plain text as well as status LEDs
- Interface for external modules SAM24, MC-LM, MCT15 via RS485BUS
- up to 6 switching inputs per changeover
- Networking of systems possible via Ethernet (TCP / IP)
- Web interface for visualization and configuration

Optional switch query module SAM24M:

- 8x switch input on terminal (200 - 255 V AC or 24 - 255 V DC) for switching the circuits in AC mode
- 2 circuit types (gDS, MB) programmable

Integrated IO module:

- 7x relay output (3x on terminal), 230 V AC, 6 A / 30 V DC, 6A, floating changeover contact
- 4x galvanically (2x on terminal) separate switching input (200 - 255 V AC or 24 - 255 V DC), reverse polarity-tolerant, function programmable

Integrated monitoring of a network monitor loop

- Monitoring of a potential-free network monitor loop for interruption

Version	Order number	Charger	Cabinet
Combi device with central unit and battery compartment 1500mm incl. charger, battery compartment up to 45Ah, AC-Feeding 1x, 2x or 3x 230V, 50/60Hz			
MDC220 / 2,5A Combi 1500 without DBU	MDG1	2,5A	1500 x 600 x 450
Surface- / Wall housing with central unit, without battery compartment incl. charger, AC-Feeding 3x 230V, 50/60Hz			
MDC220 / 2,5A ES900 without DBU	MDW1	2,5A	900 x 600 x 450
MDC220 / 5A ES900 without DBU	MDW2	5,0A	900 x 600 x 450
MDC220 / 7,5A ES900 without DBU	MDW3	7,5A	900 x 600 x 450
Tower housing with central unit, without battery compartment, incl. charger, AC-Feeding 3x 230V, 50/60Hz			
MDC220 / 2,5A ES1800 without DBU	MDS1	2,5A	1800 x 600 x 450
MDC220 / 5A ES1800 without DBU	MDS2	5,0A	1800 x 600 x 450
MDC220 / 7,5A ES1800 without DBU	MDS3	7,5A	1800 x 600 x 450
MDC220 / 10A ES1800 without DBU	MDS4	10,0A	1800 x 600 x 450
MDC220 / 12,5A ES1800 without DBU	MDS5	12,5A	1800 x 600 x 450
MDC220 / 15A ES1800 without DBU	MDS6	15,0A	1800 x 600 x 450
MDC220 / 17,5A ES1800 without DBU	MDS7	17,5A	1800 x 600 x 450
MDC220 / 20A ES1800 without DBU	MDS8	20,0A	1800 x 600 x 450

SUBSTATIONS

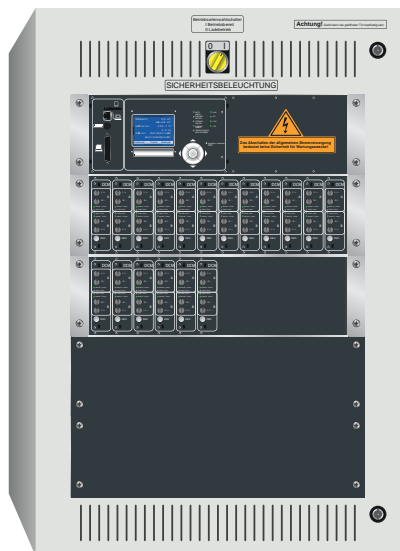

MULTICONTROL *PLUS* SUBSTATION

The multiControl plus substation is a system for connection to multiControl plus type main systems, whereby it serves to increase the number of circuits of an overall system and / or to reduce installation effort / material without its own battery.

The energy supply (AC / DC voltage) is realized by an outgoing substation in the main system.

This system can be equipped with up to 96 circuits, each of which switches independently and is fused bipolar.

Various switching states can be implemented with the circuits via switch query modules or network monitors. Up to 16 BUS modules can be connected to the system via the BUS interface.

An IO module for forwarding the system status to an external display unit or a building management system via potential-free contacts is integrated in the multiControl plus substation. The multiControl plus substation also has two programmable voltage inputs connected to the terminal. The connection to the building management system via Modbus or BACnet is possible via another interface.

The monitoring of a potential-free network monitor loop for interruption is integrated. The monitoring of the network monitor loop for clumping / closing is optionally possible.

Switched mode enables the connection of our luminaires listed in the catalog, as well as commercially available luminaires, which are designed for supply by an AC and DC voltage.

By using sub-distributors of type MCVU and MCVU-E, circuits of the multiControl plus substation can be outsourced based on the fire section, thereby reducing the fire load and the installation material.



microControl *plus* SUBSTATION

The compact substation with up to 6 circuits, based on the microControl plus, for connection to main systems of the multiControl plus type.

The range of functions corresponds to that of the microControl plus. The maximum connected load is 1500W.



FACTS

Version:	Wall housing
Cabinet:	Steelsheet RAL 7035
Dimensions:	see systems list
Protection category:	IP20 (optional IP21, IP54, E30)
Insulation class:	I
Mains connection:	3 x 230V AC (± 10%) 50/60Hz
Switched mode:	230 V AC / 216 V DC ±15%
permissible Temp.:	0°C to 35°C
Cable feed:	from Top (from below on request)

FEATURES AT A GLANCE:

- Central power supply system according to DIN EN 50171 for safety lighting systems according to DIN EN 50172 and systems according to DIN VDE 0100-718
- automatic test facility according to DIN EN 62034
- Combined switching type for standby, steady light and switched steady light
- Service-friendly modular 19 "slide-in technology
- Electronic test book for recording all data over a period of > 5 years
- multilingual menu navigation, e.g. German English
- Management and error display of up to 20 lights each circuit
- 96 circuits of max. 1300 VA
- Maximum connected load (AC operation) of the entire system consisting of main system, substation (s) and sub-distributor (-n) of 47777 VA
- Status information of the system in plain text as well as status LEDs
- Interface for external modules SAM24, MC-LM, MCT15 via RS485BUS
- up to 6 switching inputs per circuit
- Networking of systems possible via Ethernet (TCP / IP)
- Web interface for visualization and configuration

Optional light switch query module SAM:

- 8x switching input on terminal (200 - 255 V AC or 24 - 255 V DC) for switching the circuits in AC operation
- 3 circuit types (sw. maintained, maintained, non-maintained) programmable

Integrated IO module:

- 7x relay output, 230 V AC, 6 A / 30 V DC, 6A, floating changeover contact
- 4x galvanically isolated switching input (200 - 255 V AC or 24 - 255 V DC), reverse polarity-tolerant, function programmable

Integrated CCIF - Critical Circuit Interface Module

- Monitoring of a potential-free network monitor loop for interruption and termination of the line

Version	Order number	Cabinet	max. Circuits	max. DCM
multiControl <i>plus</i> Substation UCW012	UCW012	550 x 600 x 450mm	12	6
multiControl <i>plus</i> Substation UCW024	UCW024	550 x 600 x 450mm	24	12
multiControl <i>plus</i> Substation UCW036	UCW036	900 x 600 x 450mm	36	18
multiControl <i>plus</i> Substation UCW048	UCW048	900 x 600 x 450mm	48	24
multiControl <i>plus</i> Substation UCW060	UCW060	900 x 600 x 450mm	60	30
multiControl <i>plus</i> Substation UCW072	UCW072	900 x 600 x 450mm	72	36
multiControl <i>plus</i> Substation UCW084	UCW084	900 x 600 x 450mm	84	42
multiControl <i>plus</i> Substation UCW096	UCW096	900 x 600 x 450mm	96	48



SUBDISTRIBUTOR MCUV



The MCUV is a system for connecting to main systems of the multiControl plus type, whereby it is used to outsource circuits and reduce the amount of installation work and materials without its own battery.

The energy supply (AC / DC voltage) is realized through an outgoing sub-distributor in the main system.

Power is supplied by separate cables for the mains and battery voltage.

Switching from mains to battery voltage takes place separately in each circuit module.

Each sub-distributor is equipped with a UV controller on which an integrated mains monitoring system monitors the mains voltage at the MCUV.

FACTS

Version:	Wall housing
Dimensions:	see systems list
Protection category:	IP20 (optional IP21, IP54, E30)
Insulation class:	I
Energieanschluss:	230 V AC ($\pm 10\%$) 50/60Hz / 216 V DC
Switched mode:	230 V AC / 216 V DC $\pm 15\%$
permissible Temp.:	0°C to 35°C
Cable feed:	from Top (from below on request)

FEATURES AT A GLANCE:

- Power supply system according to DIN EN 50171 for safety lighting systems according to DIN EN 50172 and systems according to DIN VDE 0100-718
- Max. 48 circuits of max. 1300 W.
- Status information of the system via StatusLEDs
- Data terminals for further wiring to other MCUV systems
- up to 6 switching inputs per circuit

Optional light switch query module SAM24M:

- 8x switching input on terminal (200 - 255 V AC or 24 - 255 V DC) for switching the circuits in AC operation
- 3 circuit types (sw. maintained, maintained, non-maintained) programmable

Version	Order number	Cabinet HxBxT in mm	Circuits	max. DCM
multiControl plus UV, UV-C	MCUV12	500x400x250	max. 12	6
multiControl plus UV, UV-C	MCUV12E30	678x581x345	max. 12	6
multiControl plus UV, UV-C	MCUV24	550x600x450	max. 24	12
multiControl plus UV, UV-C	MCUV24E30	1050x650x341	max. 24	12
multiControl plus UV, UV-C	MCUV36	900x600x450	mx. 36	18
multiControl plus UV, UV-C	MCUV36E30	1150x760x575	max. 36	18
multiControl plus UV, UV-C	MCUV48	900x600x450	max. 48	24

CONNECTION DIAGRAM MC-UV / MC-US

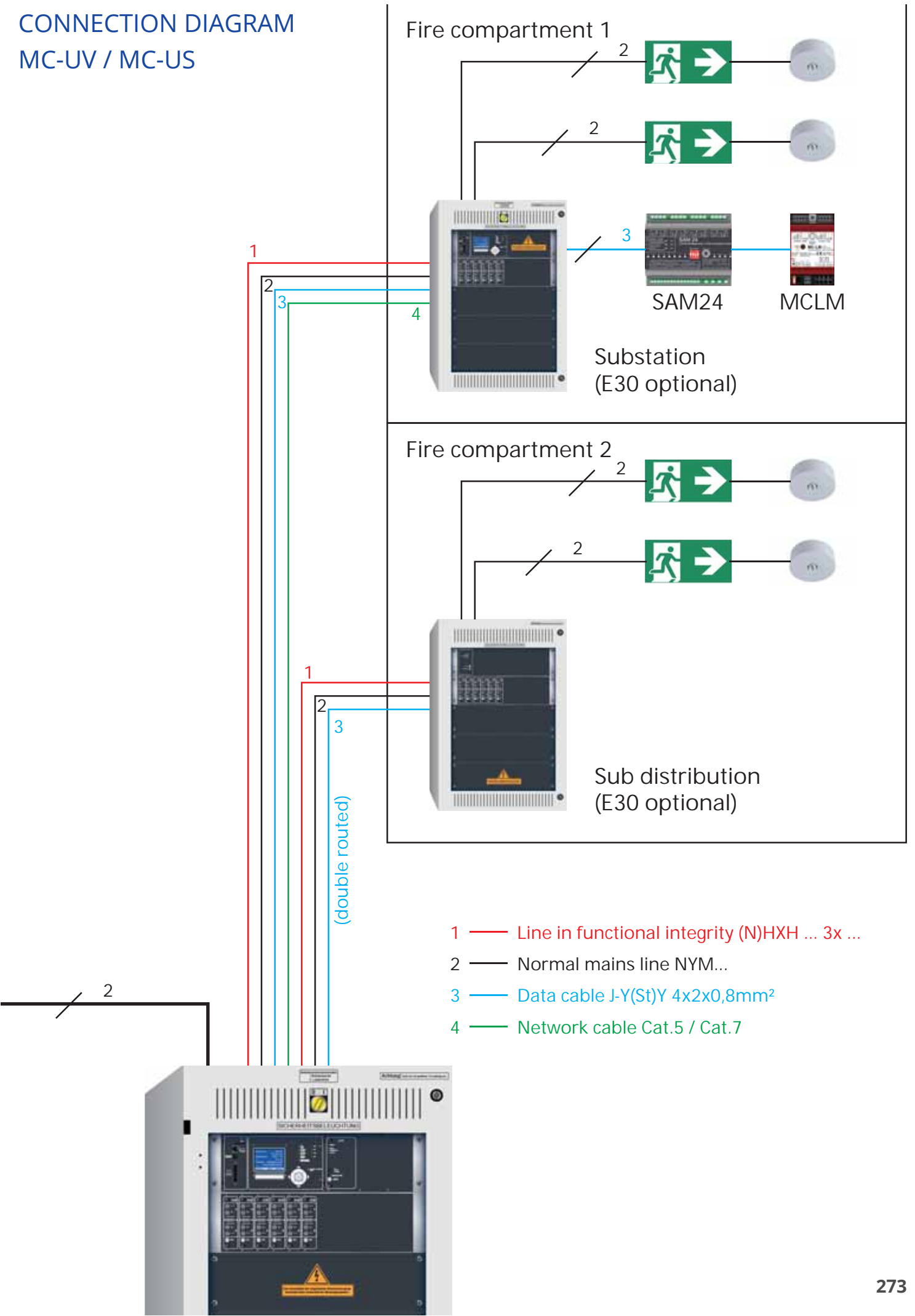

SUBDISTRIBUTION - SINGLE CONDUCTOR TECHNOLOGY MCUV-E

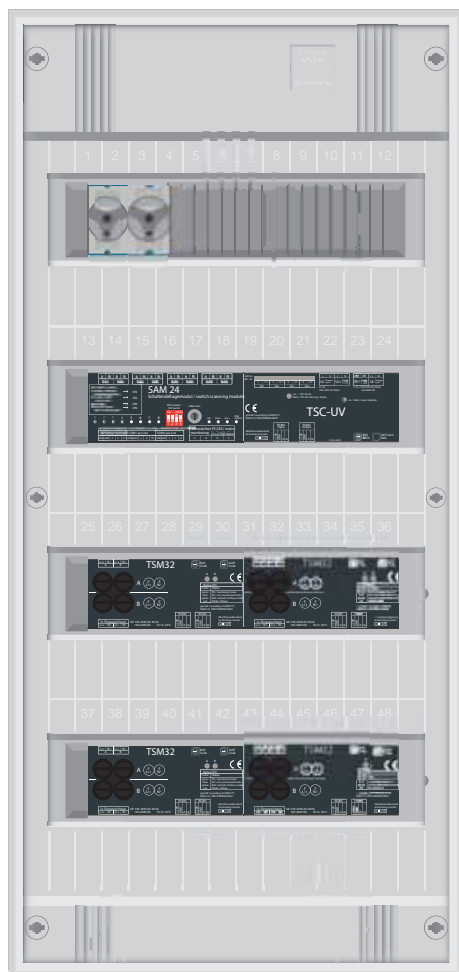

The MCUV-E is a system for connecting to main systems of the multiControl plus series, whereby it is used to outsource circuits and reduce installation effort / material without its own battery.

The energy supply (AC/DC voltage) is realized through an outgoing sub-distributor in the main system.

The energy is supplied in single-wire technology by an AC / DC switchover in the multiControl plus main system.

If the main system works in mains operation, the MCUV-E is supplied with AC voltage. The MCUV-E is supplied with DC voltage during battery or test operation of the main system.

In contrast to conventional systems with two supply lines (AC line and DC line), only one supply line (AC / DC line) is required, with which further savings in installation material can be achieved.

Each sub-distributor has four separate CCIFs, which means that four network monitor loops can be monitored individually on each MCUV-E.

An additional supply for energy supply from a local general light distributor is optionally available. This enables a tenant-related energy supply for the lights connected to the MCUV-E to be implemented. When the system is ready for operation, the luminaires are supplied by feeding the local general light distributor. The luminaires are only supplied by the main system if the general lighting distributor fails or if the main system has priority emergency or test operation.

Version	Order number	max. Mains circuits
MCUV-E02	UV multiControl plus ZBS, TSC-UV, 1x TSM32	2
MCUV-E02-LE	UV multiControl plus ZBS, TSC-UV, 1x TSM32, local feed	2
MCUV-E02-LE-SAM	UV multiControl plus ZBS, TSC-UV, 1x TSM32, local feed, incl. SAM24	2
MCUV-E04	UV multiControl plus ZBS, TSC-UV, 2x TSM32	4
MCUV-E04-LE	UV multiControl plus ZBS, TSC-UV, 2x TSM32, local feed	4
MCUV-E04-LE-SAM	UV multiControl plus ZBS, TSC-UV, 2x TSM32, local feed, incl. SAM24	4
MCUV-E06	UV multiControl plus ZBS, TSC-UV, 3x TSM32	6
MCUV-E06-LE	UV multiControl plus ZBS, TSC-UV, 3x TSM32, local feed	6
MCUV-E06-LE-SAM	UV multiControl plus ZBS, TSC-UV, 3x TSM32, local feed, incl. SAM24	6
...further configurations on request		

CONNECTION DIAGRAM

MCUV-E

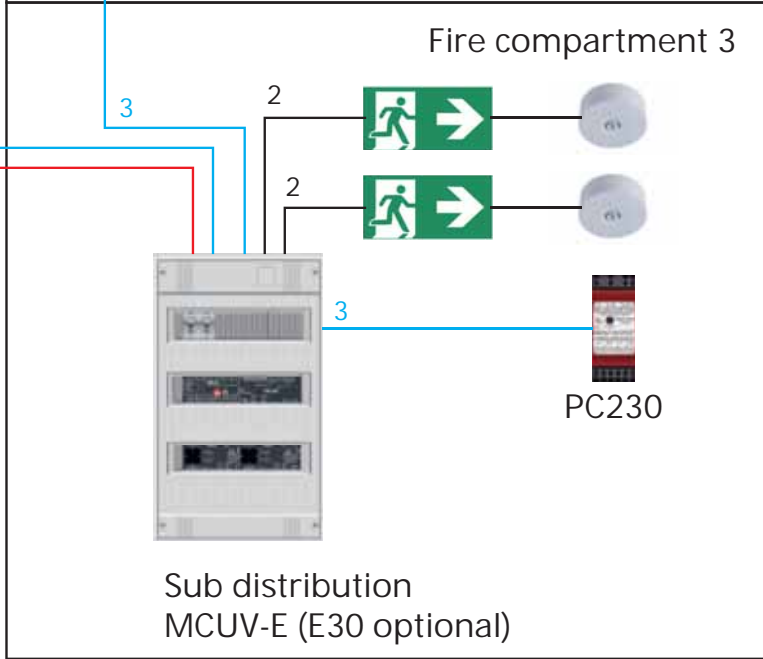
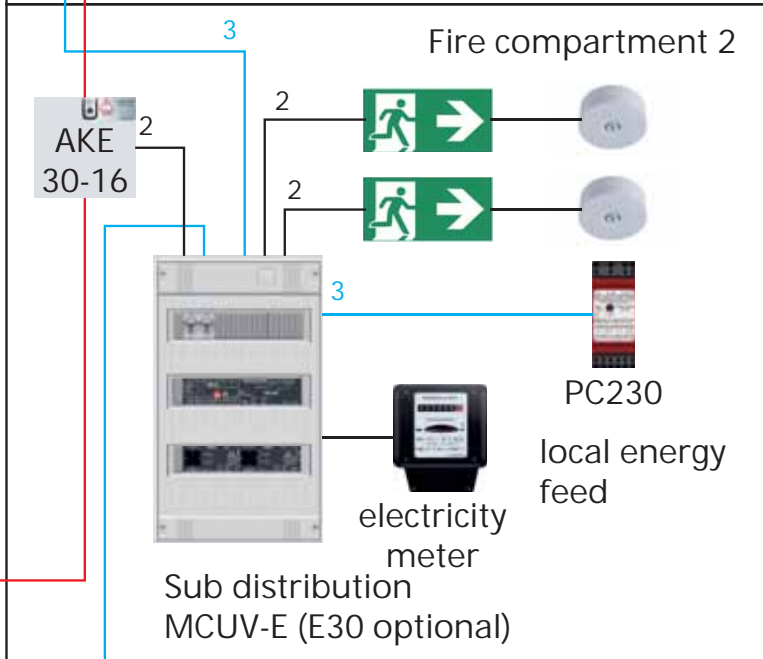
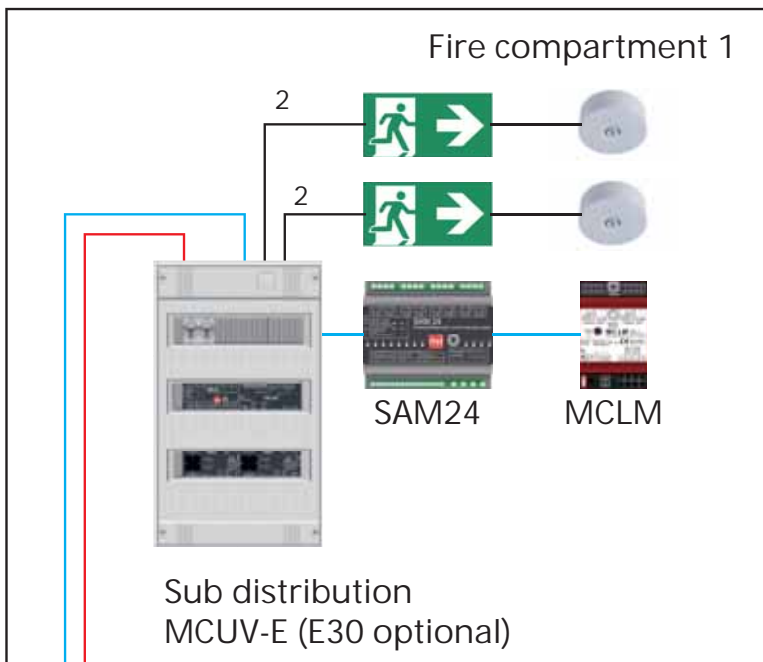
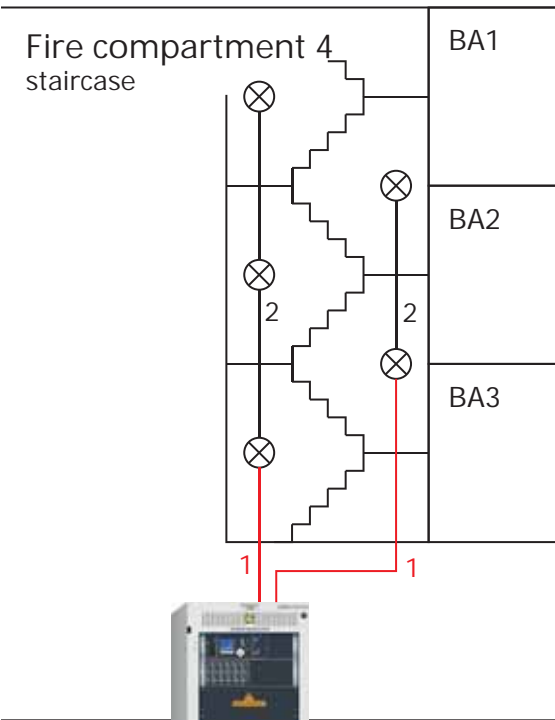

- 1 — Line in functional integrity (N)HXH ... 3x ...
- 2 — Normal mains line NYM...
- 3 — Data cable J-Y(St)Y 4x2x0,8mm²

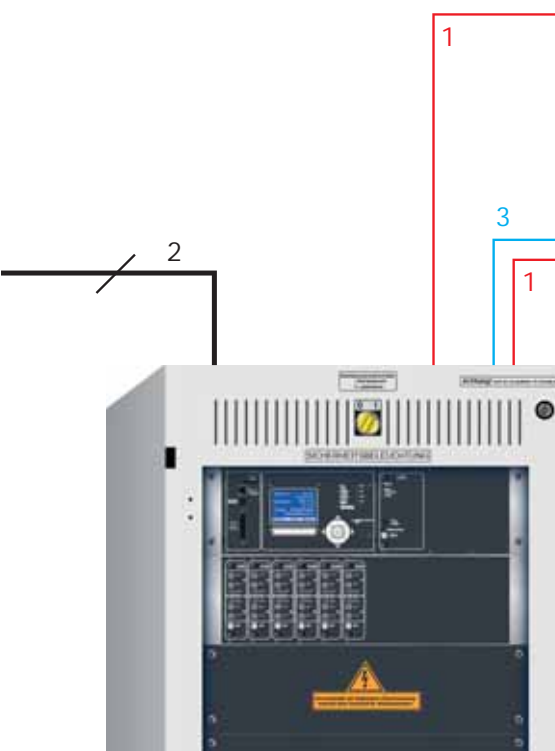

RELATED ACCESSORIES BY SYSTEM TYPE

	myControl plus	microControl plus	miniControl plus	miniControl XL plus	midiControl plus	multiControl plus
SAM24	X	X	X	X	X	X
MC-LM	X	X	X	X	X	X
MCT15	X	X	X	X	X	X
PC230	X	X	X	X	X	X
DCM32		X	X	X	X	X
DCM42				X	X	X
DCM62						X
DCM12E		X	X	X	X	X
(zus.) RSM						X
CCIF						X
CCIF-RSM						X*
SAM24M						X*
zus. IOM						X*
BAT-LOGG				X	X	X
MCABUS						X*
MCABUV						X*
UVKOP						X*
ABUV-E60						X*
ABUV-E90						X*
ABUV-E						X*
IES-5P	X	X	X	X	X	X
IES-8P				X	X	X
MC-MODBUS1				X	X	X
MC-MODBUS2		X	X			
MC-MODBUS-RTU						X
MC-BMSM				X	X	X
MC-BMSM-EXT		X	X			
MC-COMCON		X	X	X	X	X
MC-XML	X	X	X	X	X	X
MI-WLAN	X	X	X	X	X	
MC-WLAN						X
MC-MSERV	X	X	X	X	X	X
MC-MSERVM				X	X	X
MCBD04E				X	X	X
BDEXT		X	X			
APIP54	X	X	X	X	X	X*
E30	X	X	X	X		X
PLX	X	X	X	X	X	X
LUINT120						X
LUAN1/2/3/4						X
SSD				X	X	X
SSIB						X
TFST						X*
ZSU						X
ABKL						X
APSI						X
PC230E					X	X
DBU25						X*
DBU40						X*
DBU60						X*
DBU75						X*
DBU100						X*
NE16						X*
...						X*
NE63						X*

	MDC	multiControl plus Unterstation	microControl plus Unterstation	multiControl plus Unterverteiler	multiControl plus Unterverteiler Einleitertechnik	*) Bemerkungen
SAM24	X	X	X		X	
MC-LM	X	X	X		X	
MCT15	X	X	X		X	
PC230	X	X	X		X	
DCM32		x	x	x		
DCM42		x		x		
DCM62		x		x		
DCM12E		x	x	x		
(zus.) RSM	x	x				
CCIF	X	X				
CCIF-RSM	X					in comb. w. RSM
SAM24M	X	X*		X (not MCVU12)		not E30
zus. IOM	X	X*				not E30
BAT-LOGG	X					
MCABUS	X					not E30
MCABUV		X*				not E30
UVKOP		X*				not E30
ABUV-E60		X*				not E30
ABUV-E100		X*				not E30
ABUV-E		X*				not E30
IES-5P	X	X	X			
IES-8P	X	X				
MC-MODBUS1	X	X				
MC-MODBUS2			X			
MC-MODBUS-RTU	X	X				
MCBACNET1	X	X				
MCBACNET2			X			
MC-COMCON	X	X	X			
MC-XML	X	X	X			
MI-WLAN			X			
MC-WLAN	X	X				
MC-MSERV	X	X	X			
MC-MSERVM	X	X				
M CBD04E	X	X				
BDEXT						
APIP54	X*	X	X			
E30	X	X	X	X	X	
PLX	X	X	X			
LUINT120	X	X				
LUAN1/2/3/4	X					
SSD	X	X				
SSIB	X	X				
TFST	X*	X*		X*		not E30
ZSU	X					
ABKL	X	X		X*		not E30
APSI	X	X		X*		not E30
PC230E	X	X				
DBU25	X					in comb. w. RSM
DBU40	X					in comb. w. RSM
DBU60	X					in comb. w. RSM
DBU75	X					in comb. w. RSM
DBU90	X					in comb. w. RSM
DBU100	X					in comb. w. RSM
DBU150	X					in comb. w. RSM
DBU200	X					in comb. w. RSM
NE16	X					in comb. w. DBU
...	X					in comb. w. DBU
NE63	X					in comb. w. DBU

The table below helps you selecting the correct system configuration: First, find the total number of circuits of your system in the leftmost column. The column „System Type“ shows you the matching system types. Now, in the column corresponding to the required Supply Time (1h/3h/8h), look for the row showing a battery power (value in Watts to the left of the slash*) greater than or equal to the required total DC power consumption of the planned system. The value to the right of the slash now gives the number of charger modules the system must have**, while the right-most column shows you the Battery Type required***.

- * Maximum actual total DC power consumption of the planned system.
- ** The number of charger modules given ensures that the batteries will be re-charged to 80% of their nominal capacity within 12 hours according to EN 50171
- *** This battery type selection takes into account 25% of additional reserve as required by EN 50171. System Types and Battery types can only be combined as given in the table. Thus, even for a smaller number of circuits, a bigger system type might be required.

Mains circuits	System type	Supply time			Battery
		1h	3h	8h	
≤ 4	myControl plus	691 W / 1 LDM	276 W / 1 LDM	104 W / 1 LDM	OGiV 1252 LP
≤ 6	microControl plus	691 W / 1 LDM	276 W / 1 LDM	104 W / 1 LDM	OGiV 1252 LP
≤ 12 (≤ 32)	miniControl (XL) plus	715 W / 1 LDM	284 W / 1 LDM	131 W / 1 LDM	OGiV 12170 LP
≤ 32	midiControl plus	2.592 W / 1 LDM	1.201 W / 1 LDM	523 W / 1 LDM	OGiV 12260 LP
		2.514 W / 1 LDM	1.236 W / 1 LDM	569 W / 1 LDM	OGiV 12280 L
		3.309 W / 1 LDM	1.313 W / 1 LDM	626 W / 1 LDM	OGiV 12330 LP
		4.035 W / 1 LDM	1.693 W / 1 LDM	697 W / 2 LDM	OGiV 12400 LP
		4.519 W / 1 LDM	1.901 W / 1 LDM	841 W / 2 LDM	OGiV 12450 LP
		5.883 W / 1 LDM	2.604 W / 2 LDM	1.264 W / 2 LDM	OGiV 12550 LP
≤ 96	multiControl plus	5.936 W / 2 LDM	2.609 W / 2 LDM	1.152 W / 2 LDM	OGiV 12600 LP
		6.281 W / 2 LDM	2.687 W / 2 LDM	1.232 W / 2 LDM	OGiV 12650 LP
		7.275 W / 2 LDM	3.283 W / 2 LDM	1.452 W / 2 LDM	OGiV 12750 LP
		7.430 W / 2 LDM	3.283 W / 2 LDM	1.598 W / 3 LDM	OGiV 12800 LW/LPL
		8.208 W / 2 LDM	3.732 W / 2 LDM	1.702 W / 3 LDM	OGiV 12900 LP
		10.195 W / 2 LDM	4.190 W / 3 LDM	1.970 W / 3 LDM	OGiV 121000 LP
		11.491 W / 3 LDM	4.596 W / 3 LDM	2.160 W / 4 LDM	OGiV 121200 LPS
		12.960 W / 3 LDM	5.892 W / 3 LDM	2.540 W / 4 LDM	OGiV 121340 LP
		14.688 W / 3 LDM	6.160 W / 4 LDM	2.825 W / 4 LDM	OGiV 121500 LP
		21.514 W / 4 LDM	9.590 W / 5 LDM	4.320 W / 6 LDM	OGiV 122000 LP
		29.016 W / 5 LDM	12.834 W / 6 LDM	6.228 W / 7 LDM	OGiV 122600 LP



DCM32 / DCM42 / DCM-E

The **DCM circuit module**, in service-friendly 19" plug-in technology, is used for the voltage supply and monitoring of safety and escape sign luminaires. The circuit module is equipped with two circuits, each with a separate fuse. Each circuit has its own AC / DC switchover.

The **TSM32 circuit module**, in a compact cabinet for mounting on mounting rails, is used for power supply and monitoring of safety and escape sign luminaires. The circuit module is equipped with two circuits, each with a separate fuse. The AC / DC switchover takes place centrally in the main system.

Each circuit module offers the possibility of implementing individual luminaire monitoring of up to 20 luminaires and / or self-calibrating circuit monitoring per circuit.

The operation of continuous light, standby light and switched continuous light is possible. The circuit module monitors the connected luminaires or the circuit for: luminaire faults, current faults and circuit faults. A status query of the module on the system display is possible. The DCM has two status LEDs for status display, the TSM32 a multi-mobile status LED.

Circuit modules of type DCM12E additionally have the function of switching individual lights.



DCM62

The following circuit modules are available for different output powers:

Type	Fusing	maximum Load
DCM12E	2x F5A	2x 250 W
DCM 32	2x F5A	2x 650 W
DCM 42	2x F6,3A	2x 860 W
DCM 62	2x FF10A	2x 1300 W
TSM32	2x F5A	2x 650 W



TSM32

RELAY CIRCUIT MODUL, CHARGER MODULE

The **relay switching module RSM** is used to control up to two contactor switches, for the energy supply of safety and escape sign luminaires, primarily in systems of the MDC type.

The RSM has two separate contacts for switching the contactor changeovers. In addition, a separate CCIF is integrated for each contactor changeover.

Further switching options are available via SAM24 or MC-LM, e.g. switched continuous light or network monitor functions. Different run-on and supply times can be programmed separately for each contactor changeover.

The RSM has a multi-colored status LED for status display.



The **LDM25 charging module**, in service-friendly 19" plug-in technology, is used to charge battery sets in power supply systems in accordance with the applicable European and national standards.

The LDM25 has its own charge control and works with an IUTQ characteristic according to EN 50272-2.

Optimal battery life is ensured by taking current, voltage and ambient temperature into account.

The charging current of the LDM25 can be configured to 0.5 A, 1.0 A or 2.5 A depending on the system requirements.

The charging voltage of the LDM25 can be configured depending on the battery type (NICd; OGI / OPzS / OPzV or OGIV), regardless of the charging current.

The LDM25 has four status LEDs for status display.



IO-MODULE, LIGHT SWITCH QUERY MODULE



The **IO module** for forwarding system states to an external display unit or building management system via 7 potential-free contacts. In addition, 4 potential-free polarity-tolerant switching inputs are integrated.

The IO module has status LEDs for status display.



The **switch query module SAM24** is used to transmit voltage levels of general lighting to safety lighting systems of the multiControl plus series.

The evaluation of up to 8 switching inputs enables the additional switching of safety and escape sign luminaires of the safety lighting system together with the general light. An integrated 3-phase network monitor input enables the monitoring of a general light distributor.

Applying a 230 V AC voltage to U / BUS COM-boost (L3 / N of the network monitor input) prepares the BUS voltage for the module itself and all subsequent modules in the BUS. This makes it possible to compensate for losses in the BUS voltage.

The COM1 output is used for through-wiring the RS485BUS. An additionally generated RS485BUS can be tapped at the COM2 output of the SAM24. Independent of the COM1 output, an additional spur line can be implemented to connect modules to the BUS.

The SAM24 has status LEDs for status display.

Note: The connection of multiControl plus sub-distributors of type MCVU-E is only permitted at output COM1 of SAM24.

▶ CLOSED CURRENT LOOP, LINE MONITOR

The **CCIF module** (critical circuit interface module) is designed for use in devices of the type multiControl plus and MDC and ensures reliable monitoring of a network monitor loop in connection with network monitor modules of the type PowerControl PC230.

The emergency mains operation (mod. Standby) is triggered in the event of an interruption or clumping / short-circuiting of the network monitor loop and is signaled in the system's LCD with a „critical circuit“.

Cables to maintain the function for the network monitor loop are not necessary. A status LED signals the closed current loop.



The **three-phase line monitoring PC230** is used to monitor AV networks (power supply for general lighting).

A maximum of 3 phases + neutral conductors can be monitored with the PC230. The switching threshold for the detection of a power failure or a power fluctuation is 85% of the nominal power UNENN.

Two potential-free changeover contacts are used to connect to the safety lighting system.

The PC230 has a status LED for status display.



The **MC-LM** bus mains monitor (multiControl plus - Line Monitor V2) is used to monitor AV networks (power supply for general lighting).

The MC-LM is connected to safety lighting systems of the multiControl plus series via a secure RS485BUS and does not require a data line to maintain its function.

A maximum of 3 phases + neutral conductor can be monitored with the MC-LM. The switching threshold for the detection of a power failure or a power fluctuation is 85% of the nominal power UNENN.

From version V2, a potential-free relay contact enables cross-system switching, for example.

The MC-LM has a multi-colored status LED for status display.



The **MC-FLM** is a module for monitoring a local AV network and switching luminaires / lighting groups. Each MC-FLM forms its own lighting group and enables the lighting of this group to be switched together, e.g. together with the general light.

An integrated network monitor and switching input enable switching of the lights / lighting group.

The MC-FLM and the lighting group are powered by the circuit module of the safety lighting system.

The MC-FLM has a multi-colored status LED for status display.



The **MCT15 (S / U / US) remote panel** is used for the decentralized display of states of safety lighting systems of the multiControl plus series.

The corresponding status of the system is displayed optically and acoustically. The visual display is via plain text and LED. If faults occur, there is also an acoustic message.

This remote panel is optionally available with a button (MCT15 / MCT15U) or key switch (MCT15S / MCT15US) as a mode selector switch. There are also cabinet variants for surface mounting (MCT15 / MCT15S) and flush mounting (MCT15U / MCT15US) to choose from.

In plain text, the display provides information about the following status information of the safety light system:

- Battery voltage
- Mains voltage
- Battery ambient temperature
- System errors and much more

A multi-colored status LED and a red error LED signal the following system states:

- System ready for operation / loading operation
- Battery / mains operation
- Continuous light on / off
- System error

In the event of a fault, an acoustic signal sounds.



	MCT-15/MCT-15S	MCT-15U / MCT-15SU
Dimensions in mm	117 x 117 x 26 (H x B x T)	Cut-out 120x120mm

CONNECTION TO BUILDING MANAGEMENT SYSTEM

The building management system gateway forms a defined interface between building management system and central power supply systems for emergency lighting. Thus, all system and luminaire information is directly available in the building management system.

The MC-BMS controller ensures that all information from the connected emergency lighting system is read out and made accessible to the outside via ModBus or BACnet. It automatically detects which protocol is supported by the connected building management system.

Until now, one controller per system was required for this. With the MC-BMS, this is possible with only one controller for a total of 33 networked systems. Depending on the system type, it is installed directly in the control cabinet of the emergency lighting system (MC-BMSM) or in an external housing (MC-BMS-EXT).



MC-BMS-ACT

Activation of the interface function per system.

MC-BMSM

Controller integrated in emergency lighting system. Interface function activated in the main system at the factory.

An additional activation of the interface function is required for each additional system to be queried (MC-BMS-ACT).

MC-BMS-EXT

Controller in external housing. An additional activation of the interface function is required for each system to be queried (MC-BMS-ACT).

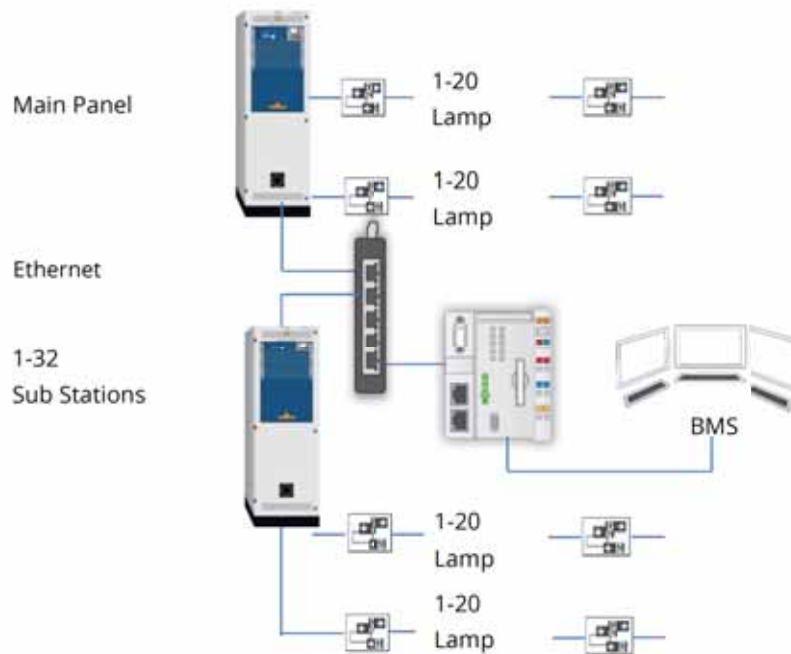



Power down switch **UW220 or UW500** for the operation with inverter devices (electronic ballast with 1 feeding AC/DC) at central power supply systems about 2 incoming wires. Max. switchover performance 250 or 500VA. Alternation voltage can be switched about the light switch of the room light as well as the AC/DC-voltage about the central supply power system. Time-delayed emergency entry with previous disconnection of the main input.

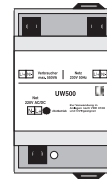
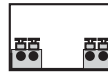

Connection UW

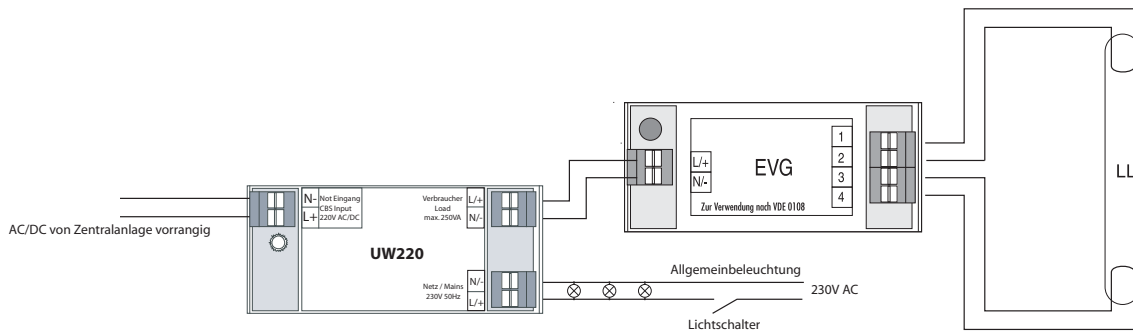

The **MU05** module is an addressable controller for use in a safety luminaire. This controller offers all switching modes and can operate a single luminaire survey. Consumers can be monitored without an auxiliary line. The general advantages are:

- compact design
- consumers load 4 up to 200 VA
- 2,5 mm² connectors with bypass connection (to safety power supply system)
- local power supply monitoring
- S' disable external dimming voltage

The power supply monitor allows connected luminaires being operated in maintained and non-maintained mode. In case of a general mains failure all luminaires are switched on.

The MU05 is designed to work with power supply systems of the multiControl plus series.

Dimensions: H=22mm, W=29mm, D=142mm.



The **housing UH1** is a universal plastic housing for accommodating the luminaire modules LPU, MLED, MU05 and NT24.

The UH1 can easily be installed through a standard ceiling cut with 74mm in a cavity ceiling. The installation depth required minimum amounts to only 100mm, because the rear part of the housing can be bent up to an angle of 45°.

UH1 allows a terminal for connection of 2.5 mm² wires to install. Strain reliefs are provided on both ends of the housing.

For concrete installation, we recommend the recessed boxes HaloX-0 + HaloX-40 from Kaiser.

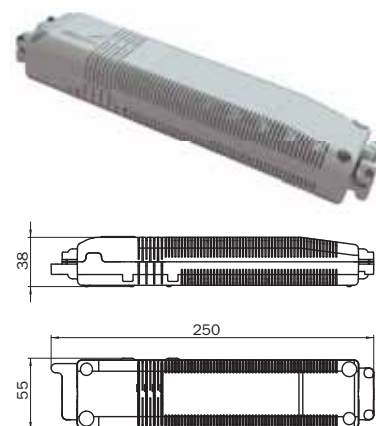

The **MU06-Box** is a plastic housing that holds the luminaire monitoring module MU06. The housing is designed in IP65 and holds the necessary terminal connectors in addition to the luminaire module.

Thus, a use of the luminaire monitoring device MU05 in humid mounting situations is possible.

Dimensions: 176 x 130 x 76mm

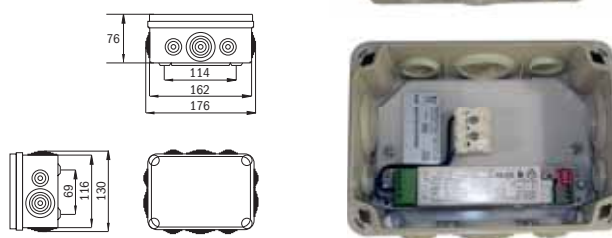



The image shows a rectangular electronic module with a white top and bottom and a green PCB. It features a terminal block on the left with four terminals labeled N, L, N, L. The top has a red emergency stop button and a green LED indicator. The PCB is populated with various components including a transformer, capacitors, and integrated circuits. A detailed technical label is printed on the PCB, providing specifications and safety information in multiple languages.



The logo consists of the letters 'HET' in a stylized, bold font, with the number '24' to its right. The 'HET' letters are white with a black outline, and the '24' is black.

The **MLED500** is an electronic switching power supply with integrated individual light monitoring, light management function, mains monitoring, dimmer and flashing functions. All switching modes are possible. The mains monitor allows the operation of connected luminaires in non-maintained mode in a maintained circuit. In case of a mains failure all lights are switched on automatically. LED illuminants with a max. output of 8W can be used as consumers.

The MLED500 is also capable of dimming the lights to 30% or 50% (cinema mode) in mains operation and to execute a flashing function in emergency operation (e.g. underground car park).

The MLED500 is suitable for use with emergency lighting systems of the multiControl plus series.

Dimensions: 143 x 38 x 27mm

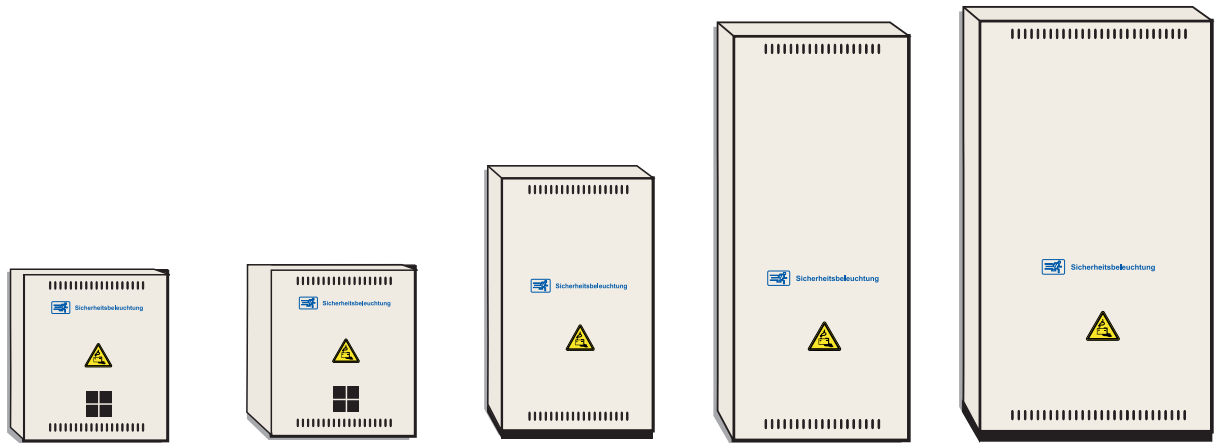

Cabinet	BATT90	BATT60	BATT11	BATT18	BATT20
Cabinet	Wall or Tower housing, door stop left	Wall or Tower housing, door stop left	Wall or Tower housing, door stop left, incl. 50mm socket	Tower housing, door stop left	Tower housing, door stop left, incl. 50mm socket
Stahlblechgehäuse	RAL 7035, IP20	RAL 7035, IP20	RAL 7035, IP20	RAL 7035, IP20	RAL 7035, IP20
Abmessungen in mm	900 x 600 x 450	900 x 600 x 600	1100 x 600 x 450	1800 x 600 x 450	1850 x 800 x 600
Kabeleinführung	Top insertion	Top insertion	Top insertion	Top insertion	Top insertion
Bestellnummer Oder number	BATT90	BATT60	BATT11	BATT18	BATT20
Optional:	Door stop right Socket 100mm Socket 200mm	Door stop right Socket 100mm Socket 200mm	-	Door stop right Socket 100mm Socket 200mm	-

The integrated ventilation slots are designed for the maximum possible battery capacity.

BATTERIES – OGIV LP

In case of emergency the safety and rescue sign luminaires are powered by maintenance free acid batteries of type OGIV in all emergency light systems. These are designed according to DIN EN IEC 62485-2 and DIN EN 50171.

The designed lifetime of these batteries is in 20° C ambient temperature up to 12 years.



Output for OGIV batteries (calculated with a set of 18 batteries)

Typ	OGiV 1252 LP	OGiV 1270 LPG	OGiV 1290 LPG	OGiV 12120 LP	OGiV 12170 LP	OGiV 12260 LP	OGiV 12280 L	OGiV 12330 LP	OGiV 12400 LP	OGiV 12450 LP	OGiV 12550 LP
Battery capacity Ah	5	7	9	12	17	26	28	33	40	45	55
Output max. 1h in W*	862 (690)	853 (680)	1134 (900)	1662 (1330)	2425 (1940)	3237 (2590)	3137 (2510)	4125 (3300)	5037 (4030)	5637 (4510)	7350 (5880)
Output max. 3h in W*	337 (270)	353 (280)	501 (400)	662 (530)	937 (750)	1500 (1200)	1537 (1230)	1637 (1310)	2112 (1690)	2375 (1900)	3250 (2600)
Output max. 8h in W*	125 (100)	158 (120)	208 (160)	275 (220)	412 (330)	650 (520)	700 (560)	775 (620)	862 (690)	1050 (840)	1575 (1260)

Number of cabinets needed for a set (18 pcs) of batteries of the entire capacity

MC-Cabinet 1000mm	1	1	1	1	1	-	-	-	-	-	-
MC-Cabinet 1500mm	1	1	1	1	1	1	1	1	1	1	-
Battery cabinet BATT90 900 x 600 x 450mm	1	1	1	1	1	1	1	1	1	1	1
Battery cabinet BATT60 900 x 600 x 600mm	1	1	1	1	1	1	1	1	1	1	1
Battery cabinet BATT11 1100 x 600 x 450mm	1	1	1	1	1	1	1	1	1	1	1
Battery cabinet BATT18 1800 x 600 x 450mm	1	1	1	1	1	1	1	1	1	1	1
Battery cabinet BATT20 1850 x 800 x 600mm	1	1	1	1	1	1	1	1	1	1	1

Required air circulation per battery set (calculated for power charging of the batteries)

Air stream with technical ventilation at least (m³/h)	0,3	0,4	0,4	0,6	0,8	1,2	1,3	1,5	1,8	2,0	2,4
Profile of the air inlet pipe with natural ventilation (cm²)	8,4	11,2	11,2	16,8	22,4	33,6	36,4	42	50,4	56	67,2

* Performance ratings with 25% aging Reserve in parantheses

OGiV 12600 LP	OGiV 12650 LP	OGiV 12750 LP	OGiV 12800 LW	OGiV 12800 LPL	OGiV 12900 LP	OGiV 121000 LP	OGiV 121200 LPS	OGiV 121200 LP	OGiV 121340 LP	OGiV 121500 LP	OGiV 122000 LPE	OGiV 122000 LP	OGiV 122600 LP
60	65	75	80	80	90	100	120	120	134	150	200	200	260
7412 (5930)	7850 (6280)	9087 (7270)	9287 (7430)	9550 (7640)	10250 (8200)	12737 (10190)	14362 (11490)	15650 (12520)	16200 (12960)	18350 (14680)	24612 (19690)	26887 (21510)	29012 (23210)
3250 (2600)	3350 (2680)	4100 (3280)	4100 (3280)	4200 (3360)	4662 (3730)	5237 (4190)	5737 (4590)	6312 (5050)	7362 (5890)	7700 (6160)	9975 (7980)	11987 (9590)	12825 (10260)
1437 (1150)	1537 (1230)	1812 (1450)	1987 (1590)	1900 (1520)	2125 (1700)	2450 (1960)	2700 (2160)	2800 (2240)	3175 (2540)	3525 (2820)	4750 (3800)	5400 (4320)	6225 (4980)
-	-	-	-	-	-	-	-	-	-	-	-	-	-
-	-	-	-	-	-	-	-	-	-	-	-	-	-
-	-	1	-	-	-	-	-	3	3	3	-	-	-
1	-	1	1	-	-	-	-	2	-	-	-	3	-
-	-	-	-	-	-	-	-	3	3	3	-	-	-
1	1	1	1	1	1	1	1	2	2	2	3	3	3
1	1	1	1	1	1	1	1	1	1	1	1	1	2
2,6	2,9	3,3	3,5	3,5	3,9	4,4	5,2	5,2	5,8	6,5	8,7	8,7	11,3
72,8	81,2	92,4	98	98	109,2	123,2	145,6	145,6	162,4	182	243,6	243,6	316,4

OGIV LONG-LIFE-SERIES (DESIGN LIFE UP TO 12 YEARS)

RPower® Typ	Voltage	Capacity	Dimensions (*= incl. Poles)			Weight	Pol	Connector
	V	Ah	L	B	H*	kg	Terminal	
OGIV1252LP	12	5,2	90	70	107	1,90	6,3mm	2,5 mm ²
OGIV1270LPG	12	7	151	65	100	2,05	6,3mm	2,5 mm ²
OGIV1290LPG	12	9	151	65	100	2,35	6,3mm	2,5 mm ²
OGIV12120LP	12	12	151	98	101	3,67	6,3mm	2,5 mm ²
OGIV12170LP	12	17	181	77	167	5,5	M5	6 mm ²
OGIV12260LP	12	26	166	175	125	9,2	M5	6 mm ²
OGIV12280L	12	30	165	125	175	9,1	M5	6 mm ²
OGIV12330LP	12	35	195	130	168	11	M6	16 mm ²
OGIV12400LP	12	42	197	165	170	13,8	M6	16 mm ²
OGIV12450LP	12	47	197	165	170	14,6	M6	16 mm ²
OGIV12550LP	12	61	229	138	213	17,2	M6	16 mm ²
OGIV12600LP	12	62	258	166	215	20,7	M6	16 mm ²
OGIV12650LP	12	67	350	167	179	22,4	M6	16 mm ²
OGIV12750LP	12	81	258	166	215	22,5	M6	16 mm ²
OGIV12800LW	12	84	260	168	214	22,4	M6	16 mm ²
OGIV12800LPL	12	84	350	167	179	22,5	M6	16 mm ²
OGIV12900LP	12	93	306	169	216	26,5	M6	16 mm ²
OGIV121000LP	12	106	330	171	222	32	M8	25 mm ²
OGIV121200LPS	12	126	330	171	222	32,5	M8	25 mm ²
OGIV121200LP	12	127	410	176	224	36	M8	25 mm ²
OGIV121340LP	12	141	341	173	287	39,5	M8	25 mm ²
OGIV121500LP	12	158	482	170	240	44,8	M8	25 mm ²
OGIV122000LPE	12	210	522	238	223	59,1	M8	25 mm ²
OGIV122000LP	12	212	522	238	223	67,5	M8	25 mm ²
OGIV122600LP	12	260	520	269	227	74	M8	25 mm ²

- Excellent high current discharge performance
- Flame retardant according to UL94-V0
- Reduced internal resistance and oversized inner cell connectors
- long service life in stand-by operation
- Impact- and break-proof plastic case made of ABS
- electrolyte is bound in fiberglass fabric (AGM = Absorbent Glass Mat Technology)
- maintenance-free operation in any position, except head first

Output for OGIV batteries (calculated with a set of 18 batteries)

Typ	OGIV 12930 HP	OGiV 121250 HP	OGiV 121600 HP	OGiV 122500 HP	OGiV 123000 HP	OGiV 123400 HP	OGiV 123500 HP	OGiV 123600 HP	OGiV 123900 HP	OGiV 124100 HP	OGiV 125000 HP	OGiV 126000 HP
Battery capacity Ah	28	35	58	80	94	110	126	140	150	156	200	230
Output max. 1h in W*	4.180 (3.344)	5.627 (4.501)	7.463 (5.970)	11.448 (9.158)	12.420 (9.936)	12.852 (10.282)	14.688 (11.750)	17.820 (14.256)	18.900 (15.120)	19.548 (15.638)	24.300 (19.440)	28.080 (22.464)
Output max. 3h in W*	1.760 (1.408)	2.369 (1.895)	3.142 (2.513)	4.820 (3.856)	5.229 (4.183)	5.411 (4.329)	6.184 (4.947)	7.502 (6.002)	7.957 (6.366)	8.230 (6.584)	10.230 (8.184)	11.822 (9.457)
Output max. 8h in W*	827 (661)	1.113 (890)	1.476 (1.181)	2.265 (1.812)	2.457 (1.965)	2.542 (2.034)	2.905 (2.324)	3.525 (2.820)	3.739 (2.991)	3.867 (3.093)	4.807 (3.845)	5.555 (4.444)

Number of cabinets needed for a set (18 pcs) of batteries of the entire capacity

Combi cabinet MCX 1850 x 800 x 600mm	1	1	1	-	-	-	-	-	-	-	-	-
Battery cabinet BATT18 1800 x 600 x 450mm	1	1	1	1	1	1	2	2	2	2	3	3
Battery cabinet BATT20 1850 x 800 x 600mm	1	1	1	1	1	1	1	1	1	1	1	1

Required air circulation per battery set (calculated for power charging of the batteries)

Air stream at least (m³/h)	1,3	1,6	2,6	3,5	4,1	4,8	5,5	6,1	6,5	6,8	8,7	10
Profile of the air inlet pipe (cm²)	36,4	44,8	72,8	98,0	114,8	134,4	154	170,8	182	190,4	243,6	280

* Performance ratings with 25% aging Reserve in parantheses

OGIV PREMIUM HIGH-POWER-SERIES (DESIGN LIFE UP TO 12 JAHRE)

RPower® Typ	Voltage	Capacity	Dimensions (*= incl. Poles)			Weight	Pol	Position
	V	Ah	L	W	H*	kg	Terminal	
OGIV12930HP	12	28	165	125	175	9,6	M5	D
OGIV121250HP	12	35	195	130	168	11,5	M6	C
OGIV121600HP	12	58	229	138	213	17	M6	C
OGIV122500HP	12	80	258	166	215	24,5	M6	C
OGIV123000HP	12	94	306	169	215	28,5	M8	C
OGIV123400HP	12	110	330	171	220	31,5	M8	C
OGIV123500HP	12	126	410	176	224	36,5	M8	C
OGIV123600HP	12	140	341	173	287	39,5	M8	C
OGIV123900HP	12	150	341	173	287	41	M8	C
OGIV124100HP	12	156	482	170	240	45	M8	C
OGIV125000HP	12	200	530	209	220	58	M8	E
OGIV126000HP	12	230	522	238	223	67	M8	E



A



B



C



D



E



F

BAT-LOGG® – BATTERY MONITORING FOR CENTRAL BATTERY SYSTEMS

Regularly monitoring the battery condition helps to detect defects in time in order to replace defective batteries before they cause damage to the remaining ones.

But let's face it: Nobody likes to tamper with a multitude of batteries in narrow space. That's reason enough to consider introducing an automatic monitoring system, especially as the amendment standard EN 50171 requires that battery conditions be checked every 5 minutes... e.g. using BAT-LOGG®!

BAT-LOGG® is an automatic monitoring system for batteries which checks and logs the status of each single battery block in a system in short time intervals. By doing so, BAT-LOGG® not only contributes to the safety and reliability of the system, but also helps to reduce maintenance efforts and costs. BAT-LOGG® was specifically designed for easy installation in narrow locations, and is also extremely cost-saving thanks to its minimalist design.

How it works

BAT-LOGG® Sensor modules measure the voltage and temperature of each battery. Each module is simply connected to the poles of a battery and glued to the battery case in order to measure its temperature reliably.

The measurement data is transmitted over the power line to a BAT-LOGG® Interface module. The module checks all measurement values and generates an error message if one or more of them lie outside the preset limits. Further, a potential-free relay contact notifies of any error event (collective fault).

The control unit of the power supply system retrieves all measurement data and error messages via a serial communication port and stores them. Messages and data regarding each battery, including current measurement values and data log, can be viewed using the system's LCD panel and Web-Interface.

**Monitors and stores voltage and temperature
without additional wiring**



BAT-LOGG® Sensor
(Dimensions: 38x34x10mm)

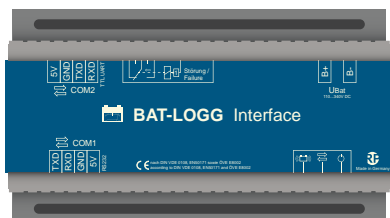

BAT-LOGG® Interface
(DIN rail module: 156x86x58mm)

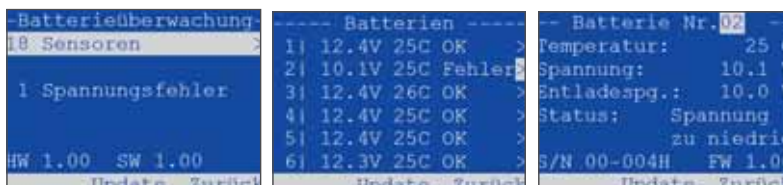

Measurement data display

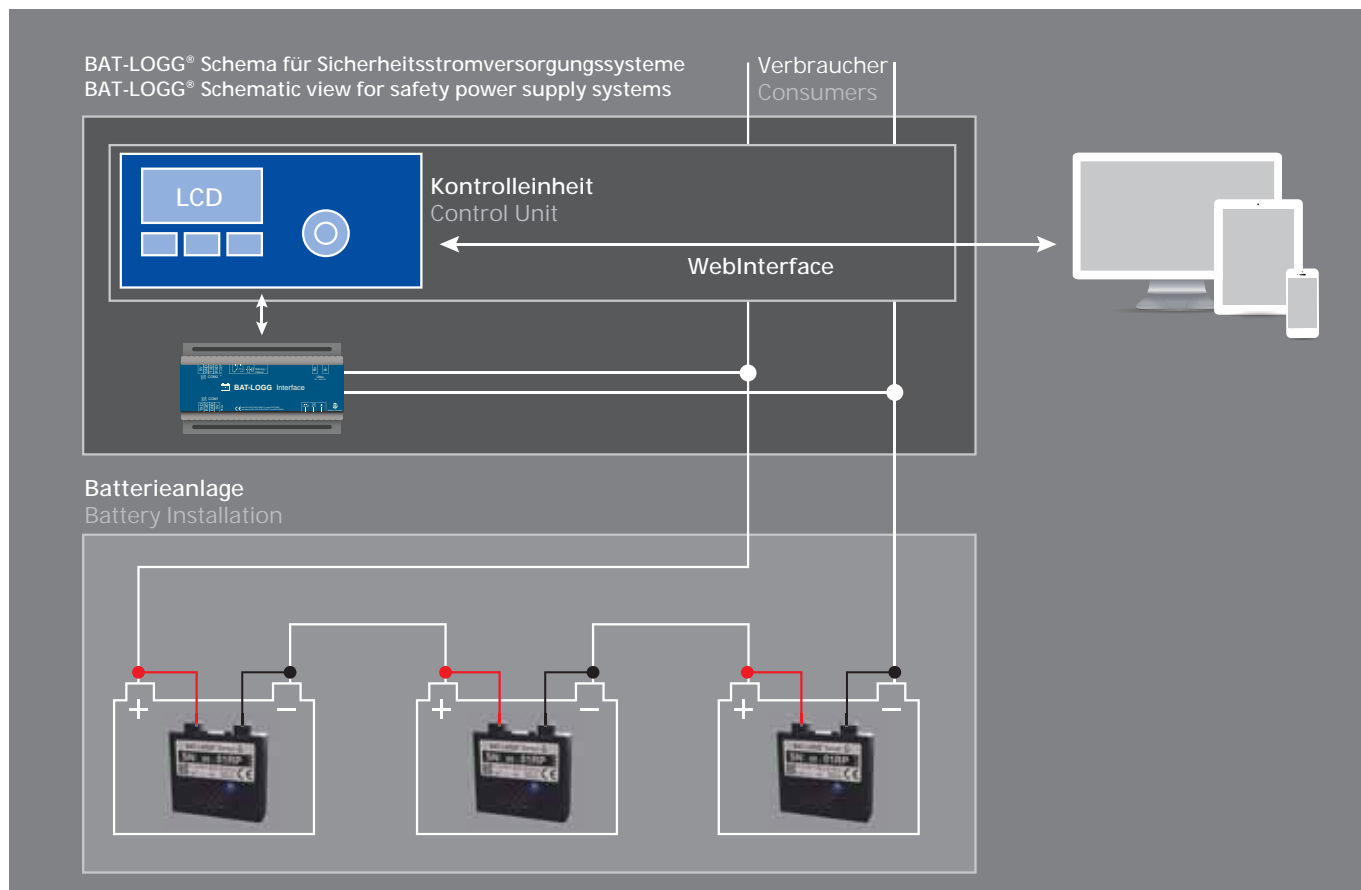

BAT-LOGG® SYSTEM SPECIFICATIONS

Monitored battery type	Lead-acid batteries with 12V block voltage (nominal)
Maximum system voltage	800V DC
Voltage measurement range (accuracy)	9.0 ... 16.0 V (±0.1 V)
Temperature measurement range (accuracy)	0°C ... 60°C (± 3°C)
Max. number of sensors supported	max. 160 BAT-LOGG® Sensor modules
Measured values	<ul style="list-style-type: none"> • battery voltage • battery temperature ¹⁾ • discharging voltage ²⁾
Measuring frequency	once per 15-20 seconds
Data logging functions ³⁾	<ul style="list-style-type: none"> • once a day, minimum and maximum value of voltage and temperature over the last 24 hours, and status information on each battery • upon each test: measurement values taken before and after the test, including discharging voltage of each battery
Monitoring functions	<ul style="list-style-type: none"> • display of all measurement values ³⁾ • display of the daily data log and test-related data ³⁾ • notification issued <ul style="list-style-type: none"> • on data transfer and communication failure • on over-/undervoltage in any battery • on excessive voltage deviation from average • on over-/undertemperature in any battery • on excessive temperature deviation from average
Other functions	<ul style="list-style-type: none"> • operation hour counter for each battery • histogram analysis for assessment of the operation conditions of each battery ⁴⁾

BAT-LOGG® Sensor

Operating voltage	12V (nominal) from lead-acid battery
LED indicator	measurement activity + battery voltage ⁵⁾
Measurements (W x H x D)	38mm x 34mm x 10mm
Protection marking acc. DIN EN 60529	IP 40
Protection class acc. IEC 61140	II
Flammability of housing material acc. UL94	V-0
Connection / mounting	<ul style="list-style-type: none"> • connection to battery poles with 6mm Faston connectors ⁶⁾ • glue to battery housing ⁷⁾
Connection cable	double-isolated, short-circuit proof cable, length: approx. 28cm ⁸⁾
Average current consumption	< 0,2mA (1,76Ah/year)
Mounting location requirements	degree of pollution rated 1 or 2 acc. EN 50178

BAT-LOGG® Interface

Operating voltage	216V DC or 230V AC (nominal)
Supported number of batteries	max. 160 BAT-LOGG® Sensor modules
Interfaces	<ul style="list-style-type: none"> • 2 serial COM communication interfaces for data exchange • single-pole switchover relais contact for collective fault indication
LED indicators	<ul style="list-style-type: none"> • collective fault (red) • COM-communication (green) • measurement data receival (green) • power on (green)
Measurements (W x H x D)	157mm x 85mm x 60mm (DIN hatrail module, 31 HP)
Mounting location requirements	<ul style="list-style-type: none"> • degree of pollution rated 1 acc. EN 50178 • for nominal system voltages > 216 V DC, an additional protection cover is required

Annotations: 1) Measured on the outer side of each battery. 2) Lowest voltage measured in each discharging cycle. 3) Functions available only in connection with emergency lighting systems of type midiControl and multiControl running firmware version 1.7.9 or higher. Full functionality is available through the Web-Interface of the system; part of the functionality is not available in the LCD menu for technical reasons. 4) Separately counting the operating hours for which voltage and temperature were inside pre-defined ranges (six voltage and six temperature ranges); these values allow for a verification of the thermal conditions and the charging/discharging operation of each battery. 5) LED flashing signals the carrying-out of a measurement and the transmission of the measured values. LED flashing twice: battery voltage is > 10,8V; LED flashing once: battery voltage is ≤ 10,8V. 6) Connecting tabs for M5/6/8 screw poles are included with the modules. 7) Double-sided adhesive strips are included with the modules. 8) Cable with Faston connector, connected to the module.

Benefits from using BAT-LOGG®

The BAT-LOGG® system can be installed quickly and inexpensively. Through automatic measuring, it saves valuable working time during the regular on-site inspection, and guarantees traceable measurement data without gap over each battery's entire period of use.

Other benefits: Less on-site operations, no more routine measurements, reduced time for traveling and maintenance, reduced operational hazards (such as electric shock), price advantage for the end user.



SMARTS LIGHT MANAGEMENT

Your advantage for quality, convenience and cost efficiency!

As a technology and development partner of CASAMBI®, the RP Group offers the solution for sophisticated lighting concepts in office buildings, hotels, hospitals, logistics centres and many other commercial applications.

CASAMBI® is the de facto standard for Bluetooth® Low Energy-based lighting and device control with intelligence and maximum ease of use.

The associated free app turns any smartphone or tablet into a remote control for the entire lighting system. Conventional control devices such as switches or motion detectors can also be integrated. In addition to new installations, the package is also ideal for retrofitting in existing buildings or for installation in areas that are difficult to access.

This extends the benefits for the user many times over. Whether in combination with DALI DT6/8, KNX; 0/1-10V, trailing edge phase control, shutter motor controls, motion detectors or push-buttons in a wide variety of designs - CASAMBI® offers interfaces for countless control options.

CASAMBI

Maximum user convenience:

- Ideal for retrofitting as no additional cables are required
- Intuitive and therefore simple operation
- Potential savings on energy costs: Up to 70 %
- No central unit required, each module is a transmitter and receiver
- Radio range of up to 50 metres inside buildings, outside up to 200 metres
- Modules for flush-mounted installation

LEARN MORE ABOUT
CASAMBI® POWERED
BY RP-GROUP
www.rp-group.com/casambi



FOR PROS.

RP-GROUP – INNOVATION MADE IN GERMANY

The products and solutions from RP-Group are now an integral part of public and commercial, but increasingly also of private properties.

For more than 40 years, we have been ensuring high levels of safety in buildings with innovative emergency and safety lighting and are one of the leading manufacturers of emergency lighting systems in Germany. Other pillars of our business are modern power supply systems, powerful batteries and innovative solutions for general lighting with smart control options. As an innovation and growth-oriented medium-sized company, we are also constantly opening up new business areas for ourselves and our partners.

Almost all of our products are engineered in Germany - many are even made in Germany. Our internal quality assurance system and various certifications - such as ISO 9001 and ENEC - ensure that our products meet the highest standards of reliability, quality and safety. It is therefore certainly no coincidence that RP-Group solutions enjoy an excellent reputation in the electrical wholesale trade and trade, as well as among lighting planners and building operators.



RP-Technik GmbH
PART OF RP-GROUP

Headquarters/Production
Hermann-Staudinger-Str. 10 - 16
63110 Rodgau

Fon +49 6106 660 28-0
E-Mail info@rp-group.com

Follow us 

 **RP GROUP**
SOLUTIONS IN SAFETY + LIGHTING

www.rp-group.com